

PB 42587

~~RESTRICTED~~

TECHNICAL ORDER NO. 05-35-4

HANDBOOK OF

Instructions *with* Parts Catalog

FOR THE

Type A-5 and A-7 AIRCRAFT SEXTANTS

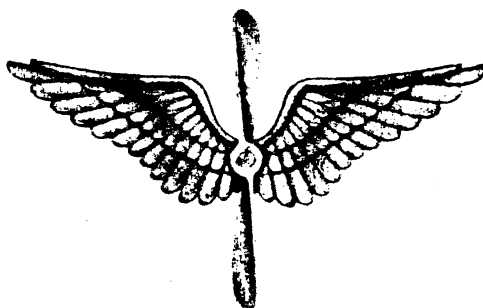

Manufactured by Pioneer Instrument Div., Bendix Aviation Corp., Bendix, N. J.

All secrecy restrictions on the contents of this document have been lifted. In quoting or citing the report, please give proper credit to the authors and the sponsoring agency. In distributing this report, the Office of the Publication Board assumes no responsibility for its completeness and accuracy or for any opinions expressed. Products and processes described may be the subject of U. S. patents, and the usual patent search is recommended before making practical applications.

National
Image Act
Violation
Prohibited.

16-47822-1 GPO

PUBLISHED BY AUTHORITY OF THE COMMANDING GENERAL,
ARMY AIR FORCES BY THE HEADQUARTERS, FIELD SERVICES,
AIR SERVICE COMMAND, PATTERSON FIELD, FAIRFIELD, OHIO

18250

RESTRICTED

T. O. No. 05-35-4

List of revision pages issued.

PAGE	LATEST REVISED DATE
27	10-10-42
29	10-10-42
31	10-10-42
32	10-10-42

PARTS CATALOG

Title Page		10-10-42
22-33		10-10-42
35-36		10-10-42
39-43		10-10-42
44-55	Deleted	10-10-42

NOTE: A heavy black vertical line, to the left of the text on revised pages, indicates the extent of the revision. This line is omitted where more than 50 percent of the page is revised.

TABLE OF CONTENTS

SECTION	PAGE	SECTION	PAGE
I	Introduction		7
II	General Description		7-8
	1. Type A-5		7
	a. Pioneer (342)		7
	b. Pioneer (1067)		7
	2. Type A-7 (A-5A)		7-8
	3. Type A-7		8
	a. Pioneer (3003-A)		8
	b. Pioneer (3003-B)		8
III	Detailed Description		9-16
	1. Telescope Assembly		9-11
	a. Objective Lens Assembly		9
	b. Astigmatizer Assembly		9
	c. Telescope Casting Assembly		9
	d. Artificial Horizon		9-11
	e. Eyepiece Prism Assembly		11
	(1) Type A-5 (Pioneer 342 and 1067)		11
	(2) Type A-7 (Pioneer 3003-A and 3003-B)		11
	2. Right Side Plate Assembly		11-13
	a. Type A-5 (Pioneer 342 and 1067)		11-12
	b. Type A-7 (A-5A)		12
	c. Type A-7 (Pioneer 3003-A and 3003-B)		12-13
	3. Left Side Plate Assembly		13-14
	4. Lamp Assembly		14-16
IV	Operation		16-20
	1. Position		16-17
	2. Use of BJ-1 Averaging Device on Type A-7 (A-5A)		17
	3. Use of BJ-4 Averaging Device on Type A-7 (Pioneer 3003-A and 3003-B)		17-18
	4. Forming the Bubble		18
	5. Removing the Bubble		19
	6. Collimations		19-20
	7. Night Operation		20
	a. Type A-5 and A-7 (A-5A)		20
	b. Type A-7 (Pioneer 3003-A and 3003-B)		20
	8. Care of Instrument after Use		20
V	Inspection and Maintenance		21-23
	1. Inspection		21
	Pre-Flight		21
	2. Maintenance		21-23
	a. Adjustment of the Sextant		21-23
	(1) Adjustment of the Telescope		21
	(2) Adjustment of Prisms		21
	(3) Adjustment of the Index Error		21-22
	(4) Adjustment for the Horizon Prism Error		22
	(5) Adjustment for Horizontal Coincidence		22
	(6) Painting of Shade Glasses to Eliminate Glare		22
	(7) Procedure for Changing the Bubble Assembly		22
	(a) Type A-5 (Pioneer 1067)		22
	(b) Type A-7 (Pioneer 3003-A and 3003-B)		22-23
	b. Adjustment of BJ-4 Averaging Device		23
VI	Disassembly, Inspection, Repair, Reassembly, and Final Tests (Depots Only)		23
	1. General		23
	2. Disassembly		23-26
	a. Type A-5 (1067)		23-26
	(1) To Remove Telescope Assembly		23
	(2) To Remove Left Side Plate Assembly		23-24
	(3) To Disassemble Telescope Assembly		24-25
	(a) To Remove and Separate Bubble and Eyepiece Assemblies		24
	(b) To Disassemble Telescope Casting Assembly		24
	(c) To Disassemble Objective Lens Assembly		24
	(d) To Remove Astigmatizer Glass and Lens		24
	(e) To Disassemble Eyepiece Prism Assembly		24-25
	(f) To Disassemble Bubble Assembly		25
	(4) To Disassemble Right Side Plate Assembly		25-26
	(a) To Disassemble Index Prism Assembly		25
	(b) To Disassemble Worm Scale Drum Assembly		25
	(c) To Remove Battery Holder		25
	(d) To Remove Spring Contact Assembly		25-26
	(e) To Remove and Disassemble Right Side Cover Assembly		26
	(5) To Disassemble Left		

TABLE OF CONTENTS

SECTION	PAGE	SECTION	PAGE
	Side Plate Assembly		26
p.	Type A-7 (A-5A) Averaging Device (BJ-1)		26-27
(1)	To Remove Averaging Device from Sextant		26
(2)	To Remove Segment Assembly from Cover		26
(3)	To Disassemble Segment Assembly		27
(4)	To Remove Dial and Vernier		27
(5)	To Remove Vernier Stop Lever Assembly		27
(6)	To Remove and Disassemble Segment Stop Screw Support		27
q.	Type A-7 (3003-A and 3003-B)		27-36
(1)	To Remove and Disassemble BJ-4 Averaging Device		27-28
(2)	To Remove Telescope Assembly		28
(3)	To Separate Left and Right Side Plate Assemblies		28
(4)	To Disassemble Telescope Assembly		28-34
(a)	To Remove and Separate Bubble and Eyepiece Prism Assemblies		29
(b)	To Disassemble Telescope Casting Assembly		29-33
(c)	To Remove Astigmatizer Lens and Glass		33
(d)	To Disassemble Objective Lens Assembly		33
(e)	To Disassemble Eyepiece Prism Assembly		33
(f)	To Disassemble Bubble Assembly		33-34
(5)	To Disassemble Right Side Plate Assembly		34-36
(a)	To Disassemble Index Prism Assembly		34
(b)	To Disassemble Right Side Cover Assembly		34
(c)	To Disassemble Worm Scale Drum Assembly		34
(d)	To Remove Bushing and Worm Assembly		34-35
(e)	To Disassemble Worm Wheel Support Assembly		35
(f)	To Remove Battery Holder		35
(g)	To Remove Spring Contact Assembly		35-36
(6)	To Disassemble Left Side Plate Assembly		36
3.	Inspection and Repair		36-37
a.	General		36
b.	Optical System		36
c.	Worm Wheel Support Assembly		36-37
d.	Wiring		37
e.	Type BJ-1 Averaging Device		37
f.	Type BJ-4 Averaging Device		37
4.	Reassembly		37-56
a.	Type A-5 (1067)		37-43
(1)	To Reassemble Left Side Plate Assembly		37
(2)	To Reassemble Right Side Plate Assembly		38-39
(a)	To Reassemble Spring Contact Assembly		38
(b)	To Reassemble Battery Holder		38-39
(c)	To Reassemble Index Prism Assembly		39
(3)	To Reassemble Telescope Assembly		39-42
(a)	To Reassemble Bubble Assembly		39-40
(b)	To Reassemble Eyepiece Prism Assembly		40
(c)	To Reassemble Objective Lens Assembly		40
(d)	To Reassemble Astigmatizer Lens and Glass in Astigmatizer Plate		40
(e)	To Reassemble Telescope Casting Assembly		40-41
(f)	To Reassemble Bubble Assembly To Eyepiece Prism Assembly		41
(g)	To Reassemble Bubble and Eyepiece Prism Assemblies to Telescope Casting Assembly		41
(h)	To Calibrate Telescope Assembly		41
(4)	To Reassemble Right and Left Side Plate Assemblies		42
(5)	To Reassemble Tele-		

SECTION

TABLE OF CONTENTS

	PAGE	SECTION	PAGE
scope Assembly to Right and Left Side Plates	42		
(6) To Reassemble Right Side Cover Assembly	42		
(7) To Reassemble Worm Scale Drum Assembly	42-43		
(8) Final Adjustments	43		
b. Type A-7 (A-5A) Averaging Device (BJ-1)	43-45		
(1) To Reassemble Segment Assembly	43		
(2) To Reassemble Dial and Vernier	43-44		
(3) To Reassemble Segment Stop Screw Support	44		
(4) To Reassemble BJ-1 Averaging Device onto Sextant	44-45		
c. Type A-7 (3003-A and 3003-B)	45		
(1) To Reassemble Left Side Plate Assembly	45-46		
(2) To Reassemble Right Side Plate Assembly	46-48		
(a) To Reassemble Spring Contact Assembly	46		
(b) To Reassemble Battery Holder	46-47		
(c) To Reassemble Worm Wheel Support Assembly	47-48		
(d) To Reassemble Bushing and Worm Assembly	48		
(e) To Reassemble Index Prism Assembly	48		
(3) To Reassemble Telescope Assembly	48-51		
(a) To Reassemble Bubble Assembly	48-49		
(b) To Reassemble Eyepiece Prism Assembly	49		
(c) To Reassemble Objective Lens Assembly	49		
(d) To Reassemble Astigmatizer Lens and Glass in Astigmatizer Plate	49-50		
(g) To Reassemble Telescope Casting Assembly	50		
(f) To Reassemble Eyepiece Prism to Bubble Assembly	50		
(g) To Reassemble Bubble and Eyepiece Prism Assemblies to Telescope Casting Assembly	50		
(h) To Calibrate Telescope Assembly	50-51		
(4) To Reassemble Right and Left Side Plate Assemblies	51		
(5) To Reassemble Telescope Assembly to Right and Left Side Plates	51		
(6) To Reassemble Right Side Cover Assembly	51		
(7) Calibration of the Worm Wheel	51-53		
(8) To Reassemble Worm Scale Drum Assembly	54		
(9) Final Adjustments	54-55		
(10) To Reassemble BJ-4 Averaging Device	55-56		
(11) To Reassemble BJ-4 Averaging Device onto Sextant	56		
(12) Final Adjustment of BJ-4 Averaging Device	56		
5. Final Tests	56		
a. Scale Error Test	56		
b. Bubble Cell Curvature Test	56		
c. Artificial Horizon Test	56		
d. Shade Glass and Astigmatizer Test	56		

Parts Catalog

FIGURE

ILLUSTRATIONS

FIGURE	ILLUSTRATIONS	PAGE
1	Side View - Type A-5 (342)	4
2	Top View - Type A-5 (342)	4
3	Side View - Type A-5 (1067)	5
4	Rear View - Type A-5 (1067)	5
5	Side View - Type A-7 (A-5A)	6
6	Side View - Type A-7 (3003-A, 3003-B)	6
7	BJ-1 Averaging Device	8
8	Bubble Assembly - Type A-5 (342)	10
9	Bubble Assembly - Type A-5 (1067, 3003-A, 3003-B)	10
10	Optical Layout - Types A-5, A-7 (A-5A)	14
11	Optical Layout - Type A-7 (3003-A, 3003-B)	16
12	Position of Operation	17
13	Position of Operation at 90°	17
14-21	Collimation	19
22	BJ-4 Averaging Device	27
23	Sectional View - Type A-7 (3003-A, 3003-B)	28
24	Sectional View - Type A-7 (3003-A, 3003-B)	30
25	Wiring Diagram - Type A-5 (1067)	38
26	Wiring Diagram - Type A-7 (3003-A, 3003-B)	46
27	Sectional View - Type A-7 (3003-A, 3003-B)	47

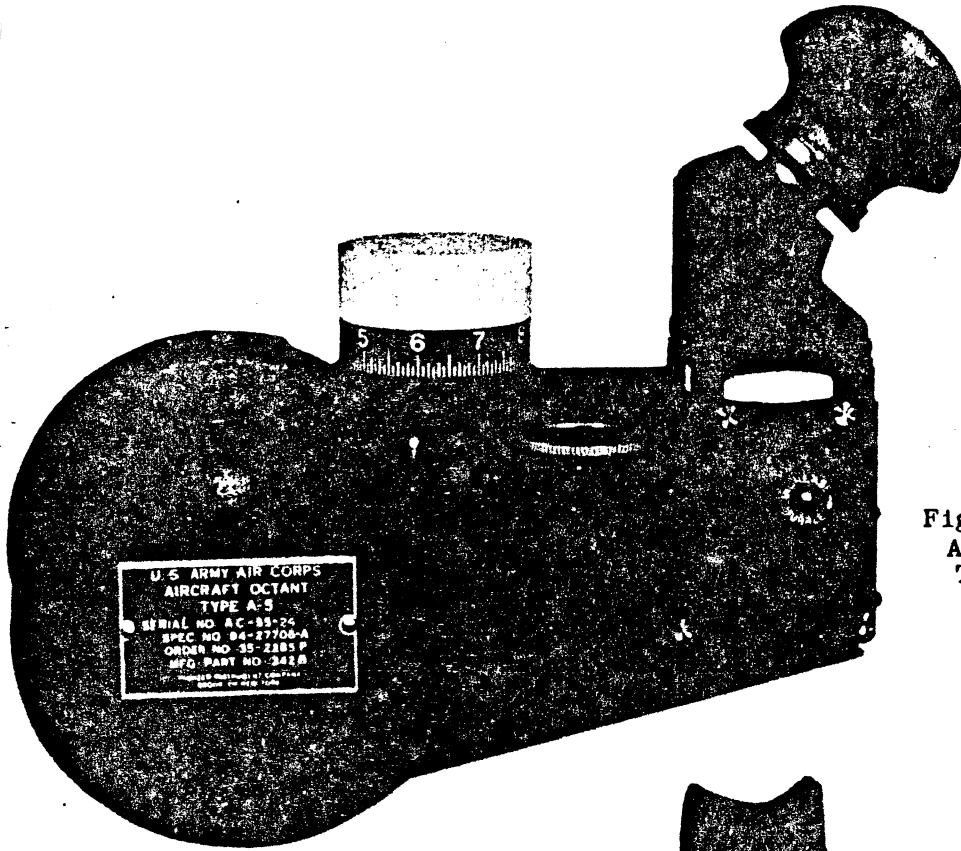

Figure 1 - Side View
Aircraft Sextant
Type A-5 (342)

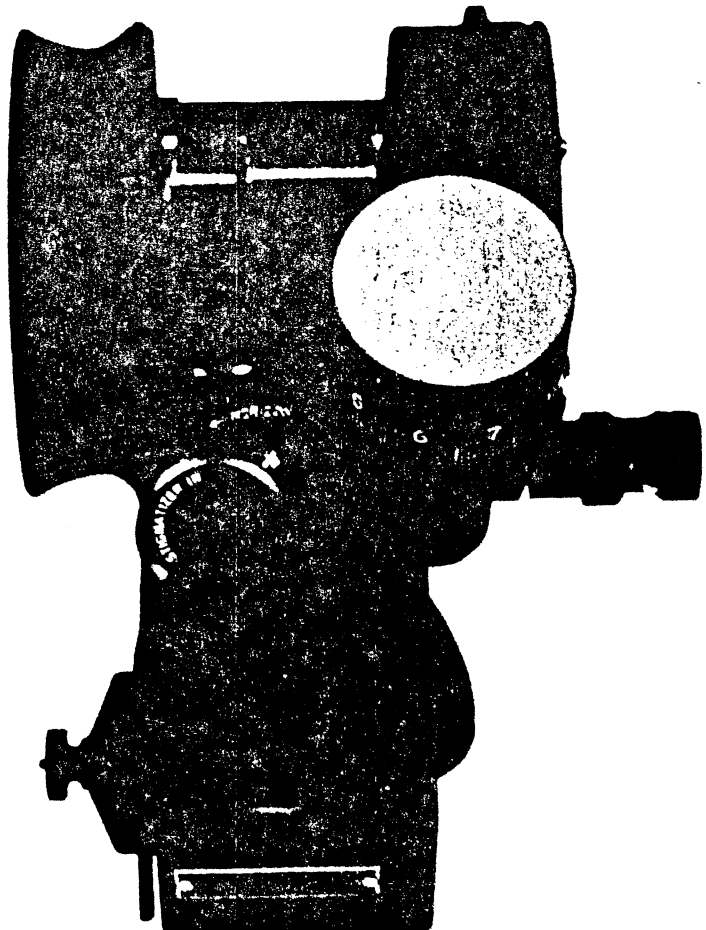

Figure 2 - Top View - Aircraft Sextant
Type A-5 (342).

RESTRICTED

T. O. No. 05-35-4

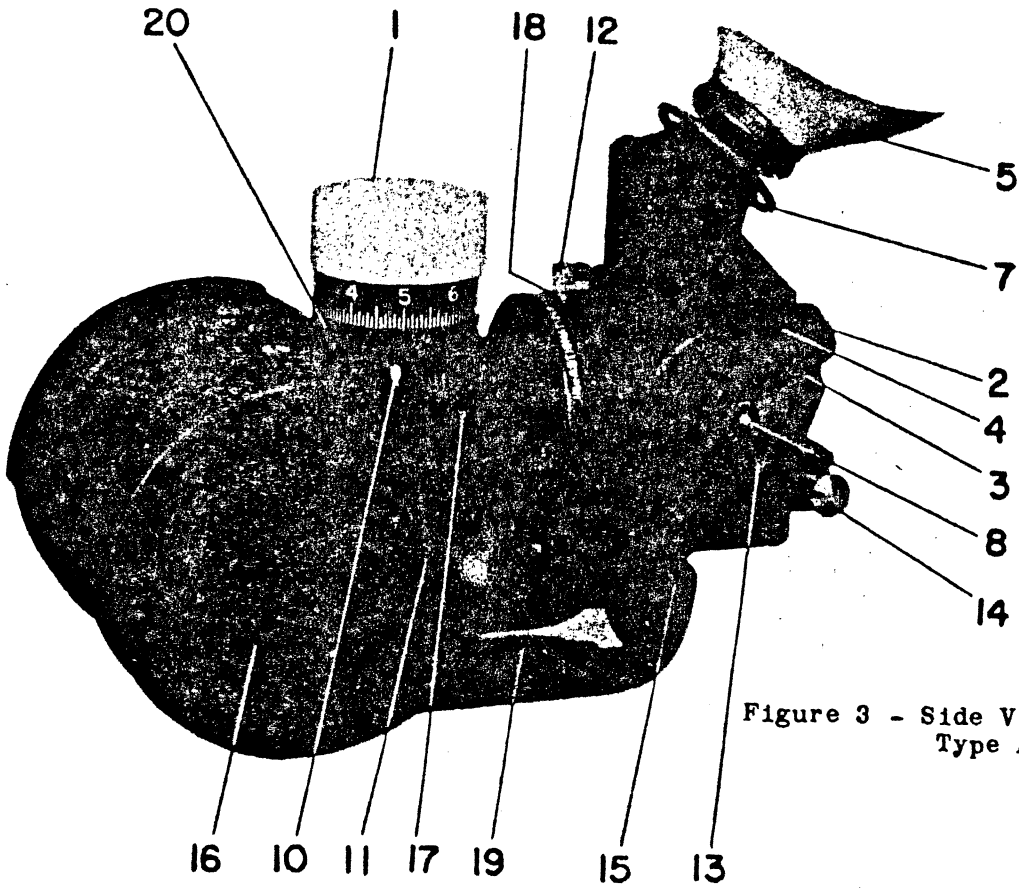
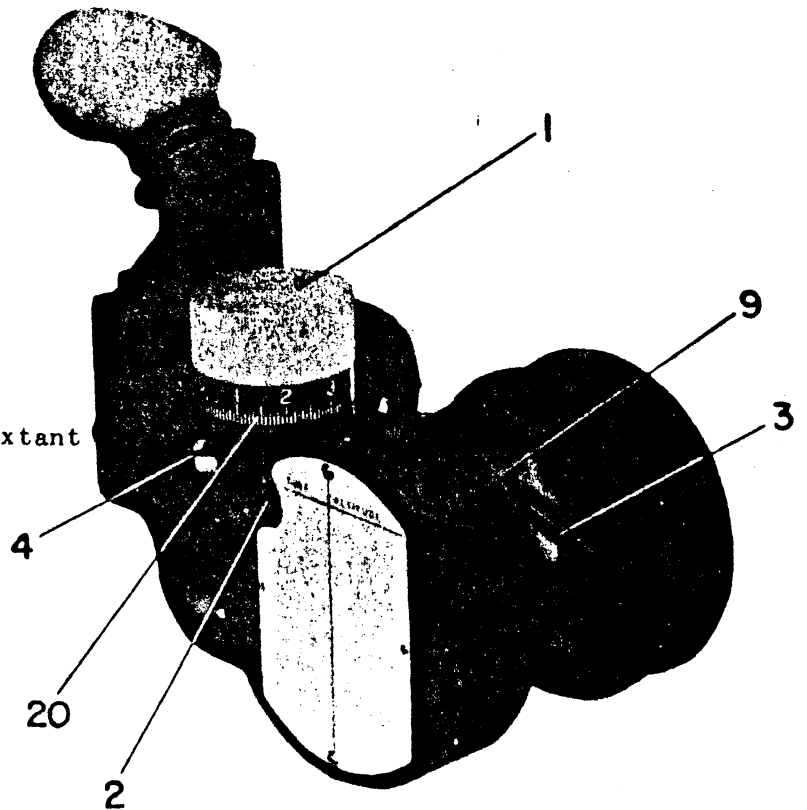

Figure 3 - Side View - Aircraft Sextant Type A-5 (1067)

Figure 4 - Rear View - Aircraft Sextant Type A-5 (1067)



RESTRICTED

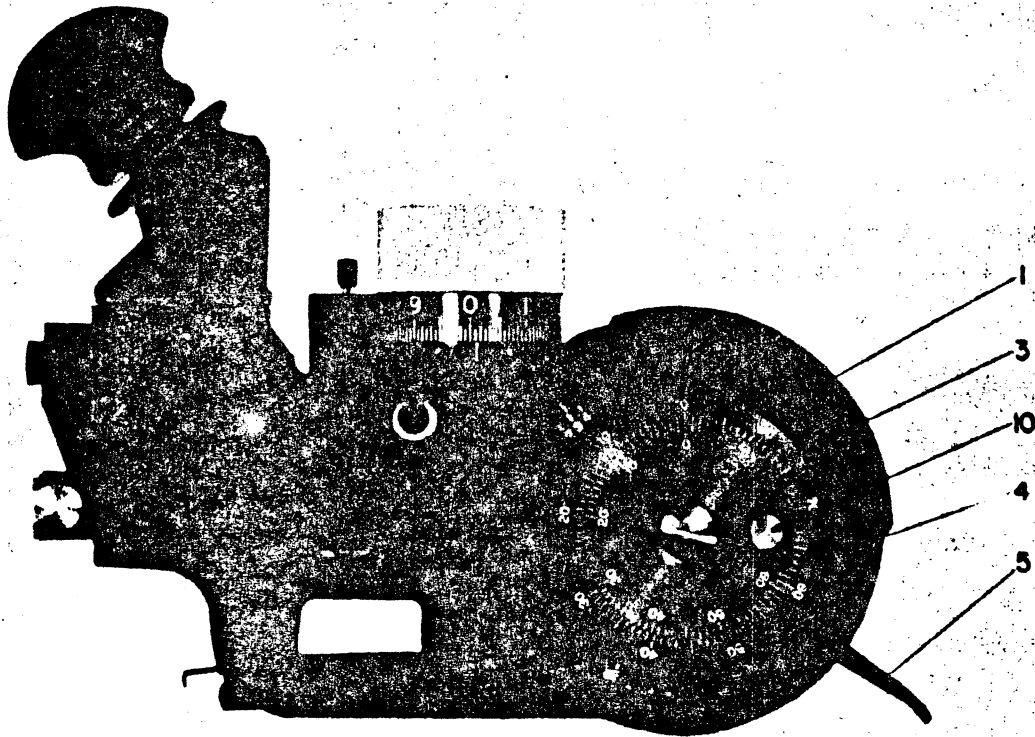

Figure 5 - Side View - Aircraft Sextant - Type A-7 (A-5A)

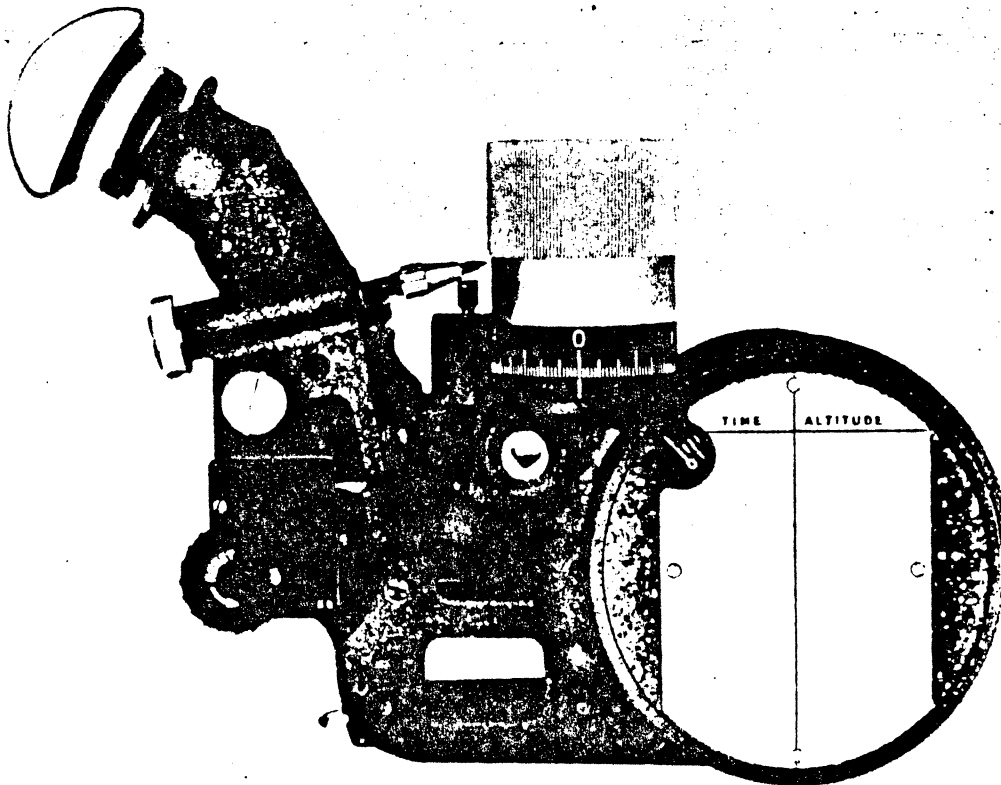

Figure 6 - Side View - Aircraft Sextant - Type A-7 (3003-A, 3003-B)

SECTION I

INTRODUCTION

1. This Handbook is issued as the general basic Technical Order for the equipment involved.

2. This Handbook contains Description, Operation, Inspection, Maintenance and Overhaul instructions for the types A-5

and A-7 aircraft sextants, which are used to measure the angular altitude of celestial bodies with reference to an artificial horizon in aircraft.

3. The following is a list of various types of sextants purchased from the Pioneer Instrument Company.

Type	Mfr's. Part No.	P. O. or Contract No.
A-5	342	35-2285-P
A-5	1067	36-5792-P
A-7 (A-5A) Modified A-5 Sextants to include	BJ-1 Averaging Device	38-5644-P
A-7	3003-A	W535-ac-15814
A-7	3003-B	W535-ac-17520
		W535-ac-17520

4. The original sextants, modified on P.O. 38-5644-P to include averaging de-

vice, were designated type A-5A during the Service Test period. Later, they were redesignated type A-7.

SECTION II

GENERAL DESCRIPTION

1. TYPE A-5

a. PIONEER (342). - This type aircraft sextant was evolved from the two-mirror open-frame quadrant sextant. Its physical shape can be seen to the best advantage in figure 1. Fundamentally, it is a telescope with two reflecting prisms, the fixed horizon prism and the rotatable index prism, placed before the telescope objective lens. The drum shaped frames which can be seen to the right and left of the prisms, figure 2, house or form the mounting bases for all the controls. To the rear of the prisms is a disc containing colored glass filters, the objective lens, and astigmatizer. The vertical part forms a base for mounting reflecting prisms, artificial horizon and the eyepiece. On the face of the right drum is a celluloid pad for recording observations and a window which

reveals the altitude reading of the observation to the nearest 10° . A small electric light screws into the side plate just under the drum to illuminate the scale and pad.

b. PIONEER (1067). - This type aircraft sextant is a modification of the type 342. The modification consists of an improved bubble cell, electric illumination of the bubble, a larger horizon field and a more uniform illumination of the data pad. Refer to figures 3 and 4.

2. TYPE A-7 (A-5A).

When the BJ-1 averaging device is mounted on the drum of any type A-5 sextant (figures 5 and 7) its type is changed to type A-7. See section 1, paragraph 4, this Handbook for explanation of type designation of the type A-5A.

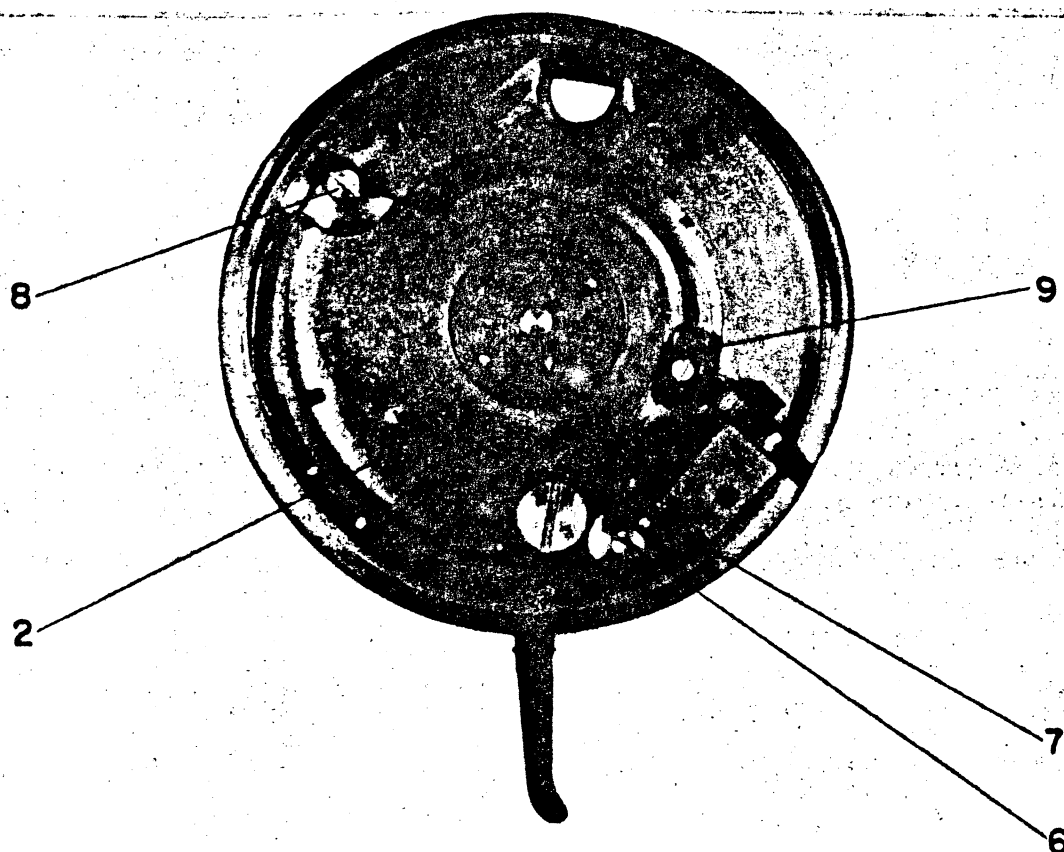

Figure 7 - Averaging Device - Pioneer BJ-1

3. TYPE A-7 (Refer to figure 6).

a. PIONEER (3003-A).

(1) This type aircraft sextant is essentially the same as type A-5, Pioneer 1067, except for several improvements. These improvements consist of a redesigned eyepiece prism assembly, a modified bubble cell, a new micrometer drum one revolution of which is equivalent to five degrees and a new averaging device type BJ-4 which records on a drum a se-

ries of observations from which an average angular altitude may be determined.

(2) The electrical system of illumination of the bubble has been eliminated from the type 3003-A.

b. PIONEER (3003-B). - This type is essentially the same as Pioneer 3003-A except that it has a die-cast astigmatizer cover, telescope body, and right and left side plates.

SECTION III

DETAILED DESCRIPTION

1. TELESCOPE ASSEMBLY.

The telescope assembly magnifies the field brought into view by the index and horizon prisms and also carries the artificial horizon system. It is made up of several minor assemblies subsequently described.

a. OBJECTIVE LENS ASSEMBLY.

(1) The objective lens assembly is made up of an objective mask, a horizon shutter and the objective lens system.

(a) The objective mask is a circular disc with an oblong opening cut symmetrically with the axis of the disc. Its function is to limit the field of the objective lens to the useful portion of the index and horizon prisms, to complete the housing of the horizon shutter, and to prevent the images of the prism holders from entering the field of view.

(b) The horizon shutter, which is directly behind the mask, is crescent shaped and has an outside radius the same as that of the objective mask. One end of the shutter is carried in a split ring which can be rotated in the objective tube by means of the shutter control knob. The outer end of the shutter is pivoted in the housing. By sliding the shutter control knob to the right, the crescent shaped shutter stands vertically across the oblong opening in the objective mask and obscures the horizon prism from view.

(c) The objective lens system is composed of a double convex lens separated by a spacing ring from a plano-concave lens. The lenses are held in place by a lens ring, which is slotted radially to make it flexible, and by a lock ring, which is threaded and screwed into the objective tube. The lenses are made up in a special crown-flint-achromatic combination.

(2) The objective lens assembly is fixed in the objective tube by a set screw.

d. ASTIGMATIZER ASSEMBLY. - The astigmatizer assembly houses an optical system capable of changing a round image into a narrow line. It is used to change the image of a celestial body into a narrow band of light to facilitate centering of the star and bubble. Whenever the astigmatizer lens is thrown out of the optical system it is replaced by a plane parallel plate glass to compensate for the change in focal length. These two glasses are held in place in the astigmatizer plate which can be rotated by the control knob. The ends of the slot, in which the knob moves, serve as stops for the rotation of the plate. Adjustment of the stop position of the astigmatizer is provided by means of the set screw in the control knob. The plate is held in place against either one of the two stops by an off-center spring.

e. TELESCOPE CASTING ASSEMBLY. - The astigmatizer plate is mounted in a bushing in the telescope casting. In this casting is also mounted the body prism held in place by the saddle-shaped holder. The form of this prism (a roof prism) is such that the light, entering one face travels through to one of the faces of the roof, is reflected to the other face of the roof and then from it, reflected upward. The path of light is thus bent through 90° and shifted over to the opposite side of the optical axis thereby reverting the image.

NOTE: The telescope casting for all types of sextants is sand cast with the exception of type A-7, Pioneer 3003-B, which is die cast.

d. ARTIFICIAL HORIZON. - (Refer to figures 8 and 9)

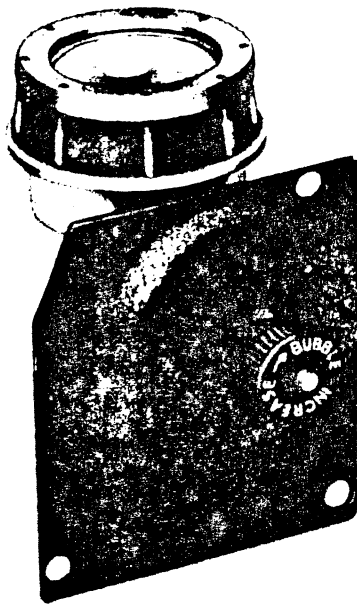

Figure 8 - Bubble Assembly -
Aircraft Sextant -
Type A-5 (342)

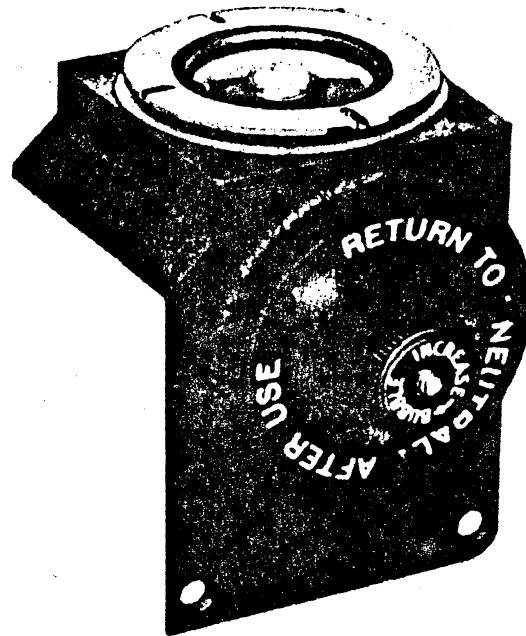

Figure 9 - Bubble Assembly -
Aircraft Sextant - Type A-5
(1067, 3003-A, 3003-R)

(1) The bubble assembly which forms the artificial horizon consists of a field lens, bubble chamber, bottom glass and diaphragm chamber with its cap. The system is used to form a vapor bubble in the bubble chamber, which together with the diaphragm chamber, is filled with Xylene, Spec. No. AN-R-X-876. The top of the bubble chamber is the glass field lens and the bottom of this chamber is the glass bubble bottom. The under surface of the field lens has such a radius of curvature that the bubble will travel the same distance as the image of a distant object when the Sextant is tilted. Both glasses are cemented to the bubble chamber and held in place by retaining rings.

(2) The bubble is formed and controlled in size by the deflection of a flexible diaphragm which forms a wall of the chamber on the side of the bubble assembly. The deflection is controlled by a nut on the diaphragm cover. By turning the nut in a clockwise direction, the diaphragm is deflected. The volume of the two chambers, which are connected by a passageway, is thereby increased and a vapor bubble is formed. The bubble formation is usually announced by a sharp click. The size of the bubble is controlled by turning the nut in either direction.

(3) On the modified type A-5 sextant (Pioneer 1067) there are two methods provided for the illumination of the bubble, electric and radium luminous material.

(a) The source of light in an electric illumination is a lamp controlled by a switch on the telescope casting, which can be screwed into the ring light socket which in turn is held in place by a small set screw in the casting projection at the rear of the telescope casting. Light from the lamp passes through the insert into the light ring made of transparent material and is then reflected upward through the bubble chamber bottom. Further reflection takes place from the inclined surface, forming the side walls of the bubble chamber and the bubble is thereby illuminated from the sides. A standard A.C. 3-volt instrument lamp, part No. 36A3344, may be used in place of special 2-volt lamp. To use the A.C. instrument lamp it will be necessary to move the butt spring contact out approximately 1/32" to insure proper contact with the lamp.

(b) Radium luminous material is painted on the under surface of the bubble bottom immediately above the light rings on a metal ring just outside the

light ring and on the two surfaces of the spacing ring immediately inside and below the light ring. This material supplies ample light to illuminate the bubble.

(4) On the type A-7 sextants (Pioneer 3003-A and 3003-B), the method of electrical illumination of the bubble has been eliminated. Radioactive luminous material, painted on a metal ring surrounding the bubble, furnishes ample light for illuminating the bubble.

e. EYEPIECE PRISM ASSEMBLY. - The eyepiece prism assembly is composed of the eyepiece prism assembly, eyepiece lens assembly and the eyepiece buffer. The base of this assembly is square and has a recess in it which fits over a raised circular step on the top of the telescope casting. The two assemblies are held together by a split retainer and spring washer so that the eyepiece lens assembly may be rotated about the optical axis of the telescope.

(1) TYPE A-5 (Pioneer 342 and 1067).

(a) The eyepiece prism on the type A-5 sextant is mounted above the field lens and serves as a means of deflecting the light path 45° . The prism is held in the housing by cork wedges.

(b) The eyepiece lens housing on the type A-5 sextant is held in a mounting inclined at an angle of 45° from the vertical and so placed that the light passing through the eyepiece prism also passes through the eyepiece lens. The eyepiece lens may be moved in or out for focusing by rotating the knurled adjusting ring.

(c) The eyepiece lens is a two-piece cemented lens composed of plano-concave flint glass and a double convex crown glass.

(d) The eyepiece buffer, shaped from soft rubber, is mounted in a circular collar which is attached to the eyepiece lens holder. The eyepiece buffer can be rotated so that it may be placed in the proper position for observing with either the right or left eye.

(2) TYPE A-7 (Pioneer 3003-A and 3003-B).

(a) The eyepiece prism on the type A-7 sextants (3003-A and 3003-B), is mounted above the field lens and serves as a means of deflecting the light path 60° . The prism is held in the eyepiece prism carrier by six prism screws and a prism retaining plate and four prism retaining plate screws.

(b) The eyepiece lens housing on type A-7 (Pioneer 3003-A and 3003-B), is held in eyepiece casting inclined at an angle of 60° from the vertical and so placed that the light passing through the eyepiece prism also passes through the eyepiece lens. The eyepiece lens is adjusted for focus by rotating the knurled adjusting ring.

(c) The eyepiece lens and eyepiece buffer used on type A-7 are similar to those used on type A-5.

2. RIGHT SIDE PLATE ASSEMBLY.

a. TYPE A-5 (Pioneer 342 and 1067).

(1) The right side assembly is mounted on the right side plate. This plate is an irregular-shaped aluminum casting. The rounded front portion houses the spindle and indicating mechanism for the index prism which is mounted between the two side plates. The index prism is an isosceles right-angle prism mounted with the hypotenuse down. This prism is made of crown glass with inclined faces polished and the base silvered and painted. The vertical surfaces are also painted. The prism is keyed into and cemented to the prism holder which is mounted on the prism carrier. The position of the prism holder with respect to the prism carrier can be adjusted by means of two adjusting screws and a regulating pivot. The prism carrier also has a shaft, which is fastened into the worm wheel assembly after this latter assembly is attached to the side plate.

(2) The worm wheel assembly consists of the female center bushing, worm wheel support and worm wheel. The female center bushing is a flanged bronzed casting,

Which is screwed to the right side plate and into which is bushed the taper of the worm wheel support. The right side plate has an opening to accommodate the shoulder on the female center bushing.

(3) The worm wheel support carries a projection on which is cut the graduations of the scale which is viewed through a window in the right side plate cover. On it is also mounted the worm wheel which is cut to engage the worm gear. The position of the worm wheel can be adjusted by means of the two screws and locked in position by means of the two lock screws. Adjustment of the position of the worm wheel is a correction for some small inaccuracies in the machining of the worm gear and wheel.

(4) The worm wheel is turned by a micrometer worm which is cut from a stainless steel rod. The shaft of the rod has a tapered bearing seat which fits accurately into a bronze bushing. The bronze bushing is held in place vertically at the upper end by a thin seating ring, which is clamped into the side plate by the worm bushing bezel. This allows the worm gear to move slightly toward the side. This movement is constrained by the adjustable worm shaft plunger assembly which pushes the worm gear against the worm wheel thereby eliminating backlash. The worm shaft is pushed upward against the tapered bushing by the spring and ball at the lower end. The shaft extends up through the bushing and above the upper edge of the side plate.

(5) The scale drum assembly is locked to the shaft by a lock nut. The worm gear and wheel are of such ratio that one revolution of the micrometer drum corresponds to 10 degrees of altitude. Hence, the drum is calibrated from 0 to 10 degrees. The units are degrees and five minutes. The 10 degree units, from 0 degrees to 90 degrees are engraved on the worm wheel support. A knurled cover is screwed over the top of the drum to facilitate its rotation.

(6) Just below the micrometer knob is a ring which carries the lubber line plate. The ring may be locked in position concentric with the knob by means of a lock screw. The position of the lubber line plate is adjustable up and down if the adjusting screws are loosened.

(7) Attached to this side plate is also the battery holder. It consists of two bakelite cradle ends, carrying contacts. After inserting the battery, in such a way that the positive pole is at the end with the single contact, the spring clip is swung into the clamped position against the battery. The engraving on this clip also indicates the position in which the battery is to be mounted.

(8) The side cover plate on which the data pad is mounted conceals the worm wheel assembly. The right side plate is fastened to the left side plate by spacing studs. The studs are rods threaded at both ends. They are screwed into the right side plate and secured to the left side plate by cylindrical nuts.

b. TYPE A-7 (A-5A). - The averaging device is shown in figures 5 and 7. Mounted on the cover casting (1, figure 5) are a plate (2, figure 7) and a vernier (3, figure 5) both of which are free to rotate on tapered bearings about a common axis. A scale (4, figure 5) is fixed rigidly to the cover casting. To the plate (2, figure 7) are secured a friction clutch shoe and a lever (5, figure 5) which, when pushed up, forces the shoe against the periphery of the vernier holder and causes it to rotate. When the lever is returned, the shoe is released, resulting in no motion of the vernier. A vernier zero stop (9, figure 7) is also provided. The vernier can be reset to zero by placing a finger on the knob (10, figure 5) and rotating the dial in a clockwise direction until stopped. The motion of the plate is limited at one side by the contact of a post (8, figure 7) with the zero stop (7, figure 7) and at the other side by the contact of the post (8, figure 7) with the edge of the worm wheel which carries the rotating prism of the sextant. The zero stop (7, figure 7) if properly adjusted, should be in contact with its stop post (6, figure 7) when, for zero reading of the instrument, the post (8, figure 7) is in contact with the edge of the worm wheel.

c. TYPE A-7 (Pioneer 3003-A and 3003-B). - The right side plate assembly is essentially the same as type A-5 (Pioneer 1067) except for differences in worm wheel support assembly, micrometer scale drum, and the addition of a new type averaging device.

(1) The worm wheel support assembly consists of a worm wheel support, worm wheel support bearing, bearing housing, index prism carrier, and worm wheel dial. The worm wheel support fits into the inner race of the worm wheel support bearing the outer race of which is secured to the right side plate by means of the bearing housing. The bearing housing is mounted on the right side plate with three screws. The shaft of the index prism carrier is a light push fit into the worm wheel support and is secured to it with a nut and washer.

(2) The rotatable index prism of the sextant is rigidly connected to the worm wheel meshing with the worm operated by means of the micrometer scale drum. The micrometer scale drum is locked to the worm shaft by two nuts. The worm gear and worm wheel are of such a ratio that one revolution of the micrometer drum corresponds to 5 degrees of altitude. The drum's periphery is divided into five major parts, each reading 1 degree. These are further subdivided into thirty parts each reading 2 minutes of arc. The worm wheel dial is visible through a window on the right side plate cover and carries a graduation line for each 5 degrees. When reading the instrument, the divisions of 5 degrees are taken through the window, while the remaining units of degrees and minutes are read directly from the scale of the micrometer drum. The knurled drum cover, which is screwed over the top of the scale drum, is provided with a surface upon which observations are recorded by the averaging device.

(3) The BJ-4 averaging device as shown in figure 24, is mounted on the right side plate at the rear. It consists mainly, of a trigger operated pencil assembly and a ratchet for indicating the number of observations up to 20. The pencil pressure against the micrometer drum cover (23) is adjustable by means of a knurled screw (1) and a thrust spring (2). The trigger (6) is attached to the base plate (10) by means of a stud (22) on which the trigger pivots. On the base plate are located a ratchet (18) and trip pin (20). The ratchet turns on a pivot (16) attached to the base plate. The ratchet spring (19) is located on the stop (8) which is firmly attached to the trip pin by means of a taper pin (7).

When the trigger is pressed backwards by a motion of the right thumb, it pushes the trip pin through the opening in the base plate. As the trip pin is pushed in, the ratchet spring (19), which is attached to the stop by a screw (15), pushes against the ratchet (18). As the ratchet is rotated counter clockwise to the next number, a ratchet stop spring (9), located at the bottom of the base plate to the right of the ratchet, falls into place. The ratchet stop spring holds the ratchet so that the numeral on the ratchet appears in the center of the plate cover cutout.

At the same time as the trigger is pressed backward, the pencil (24) places a vertical mark on the gray surface, directly above the scale, on the drum cover (23). As the trigger is released, the trigger spring (21) moves the trip pin back into place and returns the pencil assembly to its original position. Thus a series of observations may be recorded to determine the average angular altitude.

3. LEFT SIDE PLATE ASSEMBLY.

The left side plate assembly has a mounting plate similar to that on the right side. On it is mounted the horizon prism, the light switch, and the shade glass assembly.

a. The horizon prism assembly is, as to form and mounting, like the index prism. The shaft of the prism carrier is fixed to an adjusting plate after inserting the carrier shaft through a clearance hole in the left side plate. The adjusting plate has four equally spaced holes near its periphery, two of which are threaded. This plate is attached to the side plate by two mounting screws. Its distance from and its inclination to the side plate controls the position of the two prisms with respect to each other and is determined by the two mounting screws and two adjusting screws which are screwed through the threaded holes in the adjusting plate. Other screws for adjusting the prism are in the prism carrier.

b. The light switch is composed of two contact springs with silver contacts which, when pushed together by the switch button closes the electric circuit in

which the lamp illuminating the data pad and scales is found. The contact springs are insulated from the casting. One contact spring is connected electrically by an insulated wire to the light socket, the other to one contact of the battery holder.

g. The shade glass assembly is pivoted on a projection on the left side plate so that when the disc is rotated, various colored glass shades or a blank opening may be placed in the optical

system. By selecting the proper shade glass it is possible to observe luminous bodies of any intensity. The shade glass assembly is located behind the horizon prism and is rotated from the left side.

4. LAMP ASSEMBLY.

The lamp assembly screws into the right side plate under the micrometer scale drum and illuminates the scales and data pad.

5. OPTICAL LAYOUT.

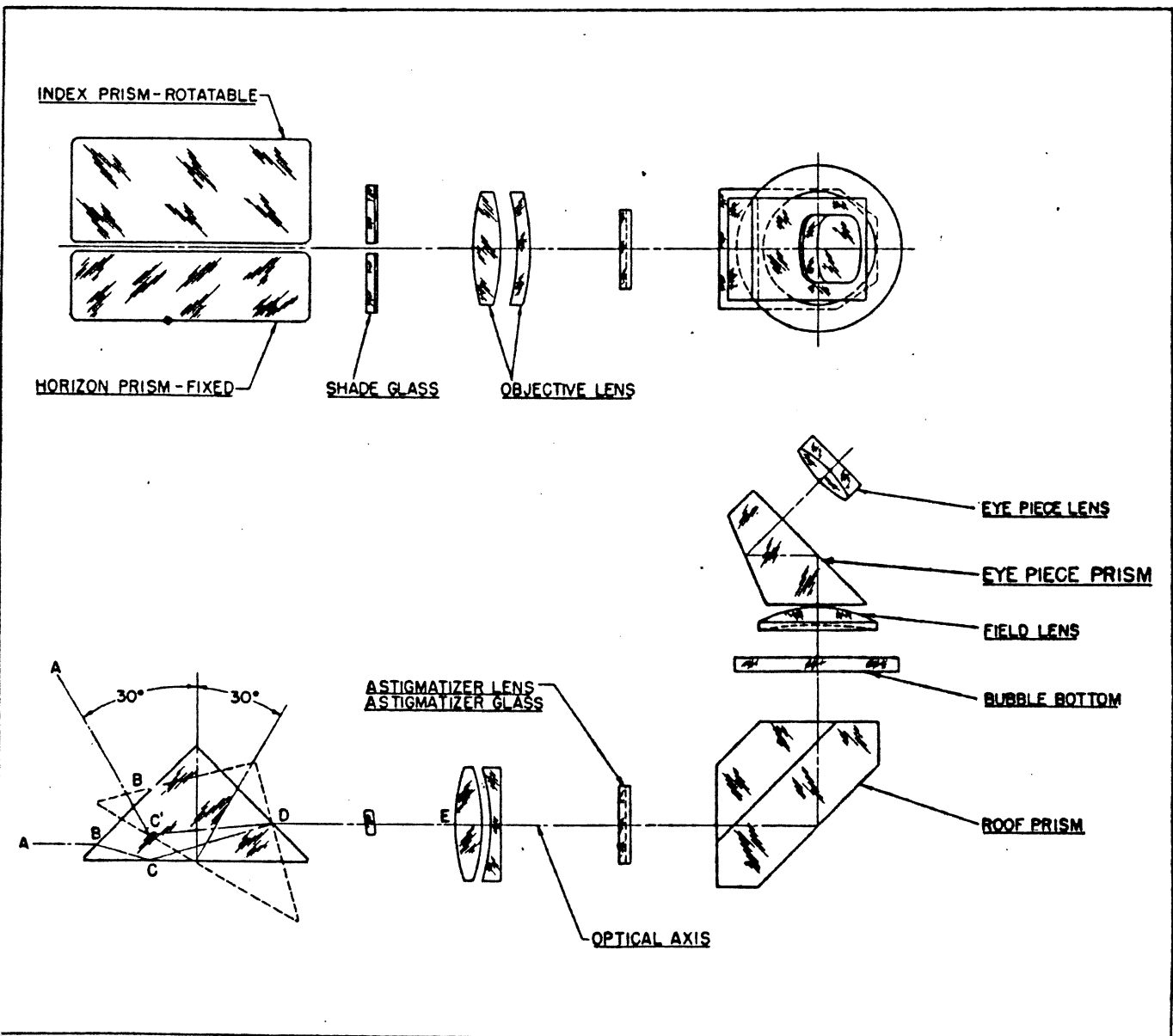

Figure 10 - Optical Layout - Aircraft Sextant - Types A-5, A-7 (A-5A)

a. Figure 10 gives a layout of the optics of type A-5 sextants (Pioneer 342 and 1067). The purpose of each part is as follows:

(1) The horizon and index prisms are both reflecting prisms. The horizon prism is stationary and is mounted on the left side plate. The index prism is rotatable and is mounted on the right side plate. The direction of the rays of light, which pass through each prism and then through the objective lens, is determined by the position of the prism. Lines ABCDE and A'B'C'DE show the path of rays of light through the prism for two different positions.

(2) The shade glass assembly is a rotatable disc containing several different colored glasses and a blank opening which enables the observer to cut down the light intensity and to produce various shades for color contrast in taking the sight. The various colored glasses are to be used when observing the sun, and the blank opening is to be used when observing stars or the moon.

(3) The objective lens causes the rays of light passing through it to come to a focus and form an image of the observed body at the bottom surface of the field lens.

(4) The astigmatizer is operated by a lever which places the lens in or out of the optical system. Its function is to elongate the image, which is an aid in centering the image with the bubble. Whenever the lens is thrown out of the optical path a parallel plate glass is substituted to compensate for a change in focal length.

(5) The roof prism bends the rays of light through an angle of 90° and also both inverts and reverts the image (turns the image upside down and from right side to left and from left side to right).

(6) Emerging from the roof prism the light rays pass through the bubble bottom, which is a piece of parallel plate glass and serves as the transparent bottom for the bubble chamber.

(7) The lower surface of the field lens is the upper boundary of the bubble chamber. Its surface has such a curvature that the bubble travels along this surface, when the sextant is tilted, the same amount as the image of the celestial body. The upper surface of the field lens causes the rays of light to converge into the eyepiece prism.

(8) The eyepiece prism bends the rays of light through an angle of 45° and brings them to the eyepiece lens.

(9) The eyepiece lens is focused on the plane of the image and bubble by rotating the eyepiece adjusting ring. It is of such a power that together with the other lenses of the system it gives a magnification of two diameters.

b. The optical layout, figure 11, of type A-7 sextants (Pioneer 3003-A and 3003-B) is identical to that of type A-5 (Pioneer 1067) with the exception of the eyepiece prism. The eyepiece prism on type A-7 sextants (Pioneer 3003-A and 3003-B) bends the rays of light through an angle of 60° and brings them to the eyepiece lens.

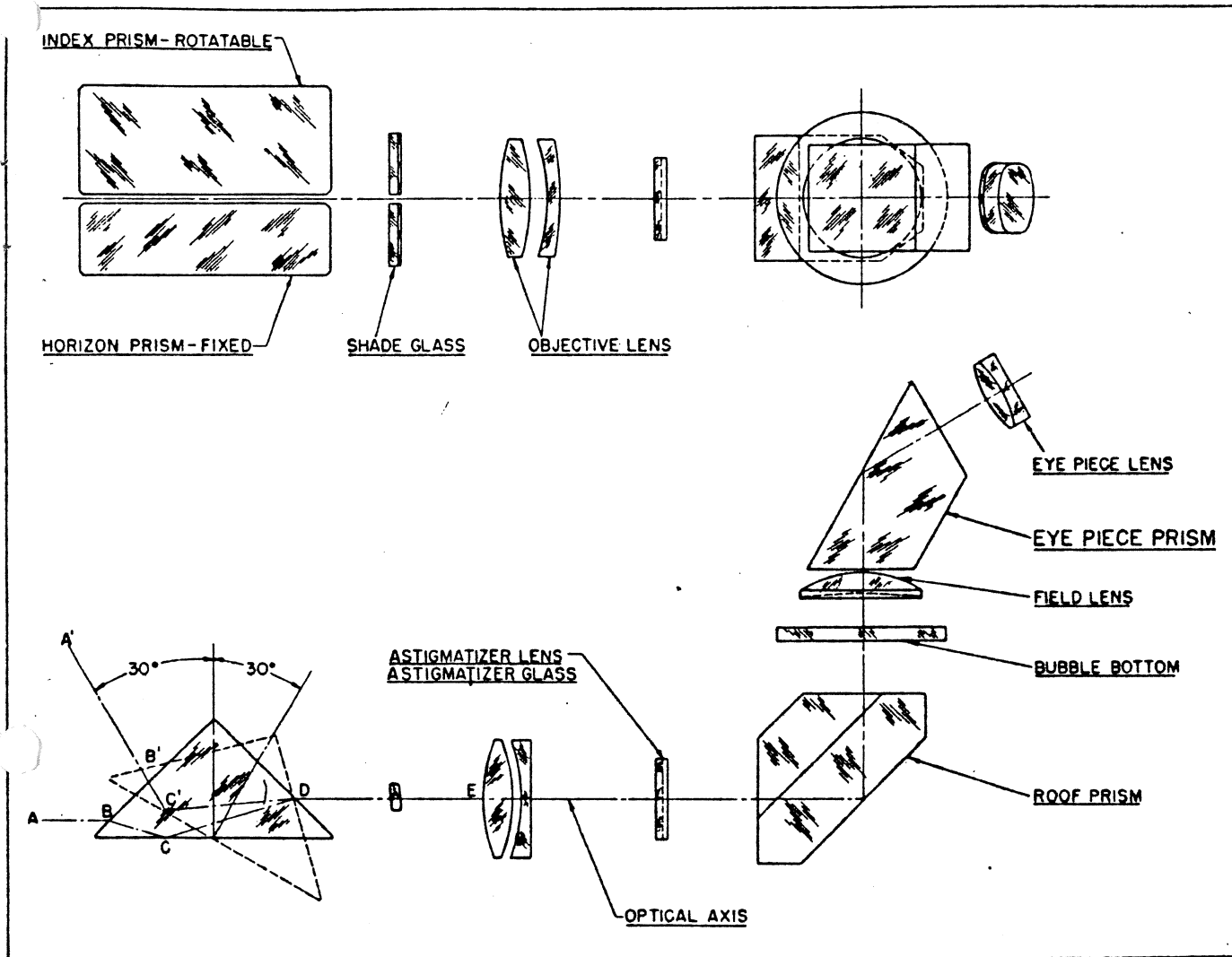

Figure 11 - Optical Layout - Aircraft Sextant - Type A-7 (3003-A, 3003-B)

SECTION IV

OPERATION

1. POSITION

The instrument should be held in both hands, the arms resting easily on the sides of the thorax, as shown in figures 12 and 13. The right hand operates the micrometer drum, while the left, besides furnishing additional support, operates the shade glass holder and the astigmatizer knob.

Figure 13 illustrates the mode of operating the instrument with the eyepiece turned 90°. When the artificial horizon is used, the horizon shutter knob should be moved to its extreme position in the direction opposite to the arrow. This will exclude any direct horizontal light from entering the telescope.



Figure 12 - Correct Position of Operation

2. USE OF BJ-1 AVERAGING DEVICE ON TYPE A-7 (A-5A).

Before taking a reading with the type A-7 sextant, be sure the vernier of the averaging device is set at zero with the lever in its lowest possible position. This is done by rotating the vernier by means of the knob in a clockwise direction until the zero marking of both scales are in line. Pull the lever as far down as possible. A sight is taken with the sextant. The lever is pushed upward until stopped, causing the vernier to move through an angle equal to the angle through which the prism has moved from its position for zero reading. The scale and vernier are so graduated that the change in reading is one fourth of the angle through which the vernier is rotated. Since the angle of rotation of the prism is one half the altitude, the change in reading is one eighth of the altitude measured. A second sight is then made and the lever operated as for the first sight. If this is done for eight sights without resetting the vernier,



Figure 13 - Correct Position of Operation at 90° Angle.

the averaging device reading will be the average value of the eight readings made with the instrument.

3. USE OF BJ-4 AVERAGING DEVICE ON TYPE A-7 (PIONEER 3003-A AND 3003-B).

Before taking a reading with this type sextant, be sure the ratchet of the averaging device is set at zero and the pencil is adjusted properly to give fine legible lines. Then, sight through the instrument and bring the image of the celestial body into horizontal coincidence with either the bubble or the image of the natural horizon. To record the observation, depress the trigger by moving the thumb of the right hand backwards without removing the hand from the sextant. Repeat this procedure, without resetting the ratchet, until the desired number of observations have been recorded. Note the number on the ratchet and select the middle reading. For example: If the ratchet reads fifteen (15), select the eighth reading. If the number on the ratchet is even, i.e., sixteen

(16), either the eighth or ninth reading may be used. Having determined the middle reading, locate its pencil mark on the micrometer drum cover. This is accomplished by starting from either right or left of the series of pencil marks and counting to the middle reading. Align the pencil mark of the average reading with the end of the pencil. Note the reading on the worm scale dial and micrometer drum scale. This quantity is the average angular altitude as determined by the observations. At the time of these observations, note the time in the customary manner.

NOTE: Before recording a new series of observations, be sure to reset the ratchet to zero and rub out all pencil marks on the micrometer drum cover.

4. FORMING THE BUBBLE.

a. Before attempting to form the bubble or change its size, various characteristics of the bubble cell should be thoroughly understood.

b. It frequently occurs that, due to conditions of pressure and temperature, a bubble is present in the diaphragm chamber independent of the fact that there may or may not be another bubble visible in the bubble chamber. This bubble in the diaphragm chamber is of such size that it cannot pass through the connecting passage into the bubble chamber. Under these conditions, rotation of the control nut in the direction used to form the bubble will increase the size of the bubble already existing in the diaphragm chamber still more and make it impossible for the bubble to pass through the passageway and appear in the bubble chamber or to combine with the one already present. The presence of the bubble in the diaphragm chamber can be easily detected by the significant reaction of the diaphragm to rotations of the control nut. Two cases should be distinguished:

(1) A bubble is visible in the bubble chamber. A rotation of the control nut will change the size of this visible bubble slower than when no bubble is present in the diaphragm chamber due to the fact that the change in pressure is also used to change the size of the bubble in the diaphragm chamber.

(2) There is no bubble visible in the bubble chamber. In this case the resistance felt when rotating the nut clockwise builds up gradually as contrasted to a sudden building up of the resistance when no bubble is present in the diaphragm chamber.

c. The above-mentioned facts suggest the following as the proper procedure to follow to form the bubble.

(1) The first step should always be, even though a bubble is visible, to hold the instrument with the control nut downwards at an angle of about 45 degrees from the vertical and rotate the nut COUNTERCLOCKWISE sufficiently to put pressure on the liquid. If a bubble exists in the diaphragm chamber this will reduce its size and it may pass into the bubble chamber. If it does not, keep the control nut in this position for a minute or two and shake the instrument from time to time. This will cause any bubble entrapped in the diaphragm chamber to either disappear or become small enough to pass into the bubble chamber.

(2) After this if no bubble has appeared, hold the instrument in the inclined position and turn the control nut clockwise far enough to just overcome the resistance which should build up suddenly. If this suddenly built-up pressure is overcome, the bubble will form and usually will be accompanied by a sharp click and the release of the resisting force on the control nut.

(3) IMMEDIATELY AFTER THIS, turn the control nut counterclockwise again in order to apply some pressure on the liquid. This will prevent the formation of too large a bubble and reduce the size of those present in the diaphragm chamber so that they can pass into the bubble chamber. Rotation of the control nut back and forth several times, each time releasing the suction which is applied on the liquid, is advisable and will speed up the removal of all bubbles from the diaphragm chamber. The nut may now be rotated clockwise sufficiently to produce a bubble of the proper size.

(4) Should the bubble fail to appear after this, start again from the first step.

5. REMOVING THE BUBBLE.

In case it is desired to remove the bubble in order to make observations with the natural horizon, turn the control

nut counterclockwise to put pressure on the liquid and leave it in that condition for a minute or two. Shaking the instrument from time to time forces the bubble to move and thereby speeds up the condensation of the vapor bubble.

6. COLLIMATION

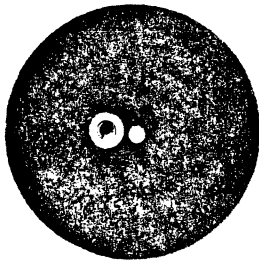

FIG. 14

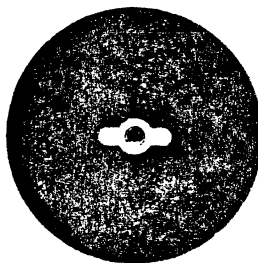

FIG. 15

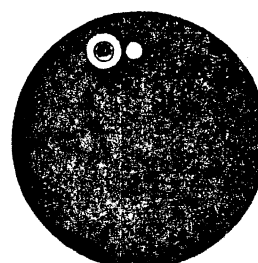

FIG. 16

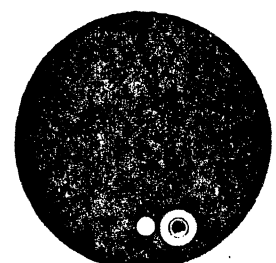

FIG. 17

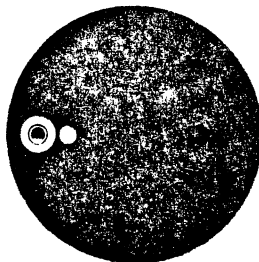

FIG. 18

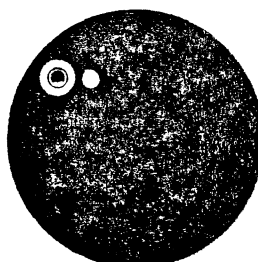

FIG. 19

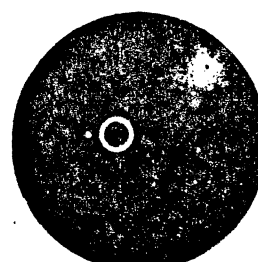

FIG. 20

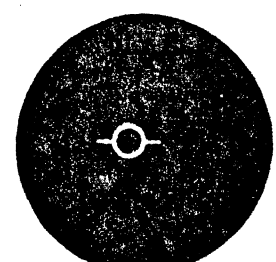

FIG. 21

Collimations

The instrument optics are so designed that the matching of the image of the bubble with that of the sun or star need not necessarily take place in the middle of the field. This matching, called "Collimation", is shown in figure 14, approximately in the center of the field. The image of the sun is brought alongside of the bubble so the center of the sun and that of the bubble are on the same horizontal line. It does not matter if the two images are collimated in the

position shown in figure 16, or in figure 17. If the two are collimated, as shown in figure 18, the resulting error will be 5 minutes, while the example shown in figure 19 also gives an error.

g. Figure 15 shows collimation when the image of the sun is astigmatized. This method is preferable for accurate work because the symmetrical arrangement of the images makes it easier to estimate the center of the bubble.

b. Figure 20 shows the same work done with a star, and figure 21 with the astigmatized image of a star.

c. Stars are not as plainly visible or identifiable when astigmatized and, consequently, the best procedure is to bring them approximately in collimation before astigmatized and then throw in the astigmatizer for final adjustment.

d. The size of the bubble which gives the best results is a little over twice the apparent size of the sun as seen in the telescope, namely, approximately 1/10 of the size of the field. This diameter is given by the distance between the outer ends of the two horizontal lines etched on the field lens. This, however, is not a hard and fast rule. The smaller the bubble the more sluggish it will be, while a large bubble will tend to move faster. Depending on the conditions, the most suitable size of the bubble is selected, trying to avoid too small a bubble.

e. The horizon and index prisms are so placed that the fields through these prisms are visible simultaneously when the eye is placed approximately at the center of the eyepiece lens. If the eye is moved to the right side the index prism field is visible, and if moved to the left side, the horizon prism field comes into view. If the eye is moved from one side to the other there is a region in which both fields are visible.

7. NIGHT OPERATION.

a. TYPE A-5 AND A-7 (A-5A).

(1) For night operation, the light furnished by the radium luminous material is usually sufficient for illuminating the bubble. Should more illumination be necessary, electric illumination is provided on Type A-5 and A-7 (A-5A).

(2) The switch (14, figure 3), mounted on the back of the telescope controls the

light. The disc (3, figure 3) when rotated varies this illumination. Only sufficient intensity should be used as to make the bubble clearly visible.

(3) The lamp for producing the illumination of the bubble is shown at (2, figure 3). The lamp bulb is removable by unscrewing it from the receptacle. A spare lamp bulb will be found in the box.

(4) A detachable lamp has been provided for illuminating the scale graduations and the record pad. It is controlled by the switch on the left side plate. The lamp holder will be found in a screw receptacle in the box. When needed, it should be screwed into the threaded hole (4, figure 4), under the micrometer drum.

(5) The battery (Bright Star No. 11 or equivalent) should be inserted into the holder under the telescope in the direction indicated on the clamp. It is not necessary to remove the paper jacket from the battery.

(6) The lamp cap should be turned so as to have the most suitable illumination, i.e., the large slot toward the data pad.

b. TYPE A-7 (Pioneer 3003-A AND 3003-B). - The illumination system for night observations on Type A-7 (3003-A and 3003-B) is essentially the same as that provided on Type A-5 except for the illumination of the bubble. The electrical system for bubble illumination has been eliminated. Also radioactive luminous material, instead of radium, has been painted on the metal ring surrounding the bubble.

8. CARE OF INSTRUMENT AFTER USE.

After using the instrument, turn the knurled nut controlling the diaphragm in counterclockwise direction until no resistance is felt. This is done to avoid useless strain on the diaphragm.

SECTION V

INSPECTION AND MAINTENANCE

1. INSPECTION.

Pre-Flight - See that the bubble can be properly formed, that the lights function and controls work properly. Sights should be taken on some distant object using both horizon and index prisms. If, for coincidence of the images, a reading of greater than 2 minutes from the zero graduation is obtained, one of the prisms has shifted in position and should be re-adjusted as described in a later section. It does not indicate which prism has shifted, but, since it is unlikely that both prisms will shift the same amount, it will indicate when an adjustment of the instrument should be made.

2. MAINTENANCE.

a. ADJUSTMENT OF THE SEXTANT.

(1) ADJUSTMENT OF THE TELESCOPE. The objective lens must be in such a position that the image formed from a distinct distant object (800 or more feet distant) or a collimator adjusted to give parallel rays of light on the same plane as that occupied by the bubble in the bubble cells. To do this focus the eyepiece sharply on the bubble. Move the eye up and down a small distance and if there is no parallax, i.e., no relative motion between the image and the bubble, the objective is properly adjusted. The image and the bubble should both appear sharp. If parallax is present, the objective lens assembly must be moved enough to eliminate it. The set screw at the top of the telescope tube and to the rear of the horizon shutter housing holds the objective lens assembly in place. It may be necessary to file the clearance hole for the set screw before replacing it after adjustment.

(2) ADJUSTMENT OF PRISMS.

(a) The prisms may require adjustment because of the following errors:

1. Index Error - The index prism image of the horizon at zero reading does not coincide with the bubble.

2. Horizon Prism Error. - The horizon prism image of the horizon does not coincide with the bubble.

3. Horizontal Non-Coincidence - The horizon and index prism images of some vertical object do not coincide.

(b) For these adjustments an accurately set horizontal collimator or natural horizon should be used. If a collimator is used, it should preferably have a horizontal collimation line. If no collimator is available, a light or line some 800 or more feet distant, exactly at the same height as the Sextant may be used. The light or line should be located by means of a transit or surveyor's level. For convenience, the Sextant should be clamped to some rigid structure during the checking and read-instrument operations. The bubble, about 3/32" in diameter, should be formed and be approximately in the middle of the field. If the natural horizon is used, correction for the "Dip of the Horizon" should be applied.

(3) ADJUSTMENT FOR THE INDEX ERROR.

(a) A sight should be taken on whatever horizon, as mentioned above, is being used and this line should be brought in collimation with the bubble. When this condition is attained, the vernier scale on the micrometer drum should read zero if the instrument is in adjustment. The horizon shutter should be moved to its extreme position in the direction opposite to the arrow during this operation.

(b) If the error is smaller than 10 minutes, the adjustment can probably be made by shifting the lubber line ring carrying the reference mark holder. This ring is clamped in place by a screw on the back side of the ring. Care must be taken that the reference mark holder does not touch the bottom of the micrometer drum. It should be possible to insert a sheet of thin paper between them. Adjustment of the reference mark holder may be made if the screw on each side of the reference mark is loosened.

(c) If the error is greater than 10 minutes, the previous method is unsuitable, as it will require shifting the reference mark holder too much for convenient observation. Lock the reference mark holder in the best position for observation and set the micrometer drum to read zero after which the rotatable prism itself must be adjusted until the horizon is in collimation with the bubble. To perform this operation there are two adjusting screws on the underside of the prism carrier. These screws may be turned by either a screw driver or a pin and upon completion of the adjustment should be tight but not tight enough to put excessive strain on the prisms.

(4) ADJUSTMENT FOR THE HORIZON PRISM ERROR. - If the horizon prism and index prism images, after making the adjustment for the index error, do not coincide, for a zero setting of the micrometer drum, the horizon prism must be adjusted by means of the adjusting screws on the underside of the prism carrier.

(5) ADJUSTMENT FOR HORIZONTAL COINCIDENCE. - It may also be necessary to adjust the prisms for horizontal coincidence, that is, the images of some vertical object do not coincide exactly. Set up the sextant with the bubble at the center of the field and sight on a vertical line which passes through the center of the field. If the lateral position of the line shifts when the micrometer drum is turned, the prism must be adjusted by means of the adjusting screw underneath the index prism carrier. The image through the horizon prism must then be adjusted to coincide with the image through the index prism. This is accomplished by removing the left side cover assembly by loosening one and tightening the other of the two mounting screws that secure the adjusting plate to the left side plate.

(6) PAINTING OF SHADE GLASSES TO ELIMINATE FLARE. - If there is any noticeable flare from the horizon prism while sighting through the index prism, it will be necessary to paint a small portion of the index prism shade glasses with optical black to eliminate the flare. This condition may arise from a slight shift of the horizon prism causing a flare in the index prism field.

(7) PROCEDURE FOR CHANGING THE BUBBLE ASSEMBLY. - In some cases it may be necessary to change the bubble assembly on the sextant. This may be occasioned by breakage of the glass lens or bubble bottom or by inability to form the bubble.

(a) TYPE A-5 (PIONEER 1067).

1. Rotate the eyepiece to an intermediate 45° position. Remove the four bubble chamber top screws and the two side screws on the left side of the chamber. The eyepiece prism and bubble assemblies may now be removed.

2. Tip the assemblies over and remove the four flat head screws which secure the eyepiece prism assembly to the split retainer. Remove the split retainer and the spring washer under it, and assemble them into the new bubble assembly.

3. Remove the three screws and take out the spacing ring, the luminous paint ring, the aluminum reflector and the light ring from the old bubble assembly.

4. Reassemble these parts into the new bubble cell. Care must be taken that the V-shaped notch in the light ring is placed directly in front of the insert, which is cemented in the semi-circular notch in the side of the chamber. The aluminum reflector is placed in the V-shaped notch in the light ring. The luminous paint ring is held in place by a slight spring tension.

(b) TYPE A-7 (PIONEER 3003-A AND 3003-B).

1. Rotate the eyepiece prism assembly to an intermediate 45° position. Remove the four bubble chamber top screws and the two screws on the left side of the chamber. The eyepiece prism assemblies may now be removed.

2. Tip the assemblies over and remove the four flat head screws which secure the eyepiece prism assembly to the split retainer. Remove the split retainer and the spring washer under it, and reassemble them into the bubble assembly.

3. Reassemble the new bubble assembly to the sextant by reversing steps 1. and 2., this section.

b. ADJUSTMENT OF BJ-4 AVERAGING DEVICE (Refer to figure 24).

(1) It may be necessary for smooth accurate operation of the BJ-4 Averaging Device used on Type A-7 (Pioneer 3003-A and 3003-B), to adjust the pencil assembly for proper travel and pressure of the pencil (24) against the micrometer drum (23). Adjustment of the travel is accomplished by removing the cover screw (2f) and the cover (28), and loosening the nut (17) on the adjusting screw (14). By means of the adjusting screw, adjust the travel of the pencil assembly to that shown in the figure. Lock the adjusting

screw (14) in position with the nut (17) and replace the cover and cover screw.

(2) To permit removal of the pencil lead, back out the pencil assembly by means of the knurled knob (1). Sharpen the point if necessary, and replace pencil assembly into the trigger (6). Adjust the pencil assembly so that a fine legible line is marked on the micrometer drum (23) when the trigger (6) is operated.

(3) If the tension on the ratchet spring (19) is insufficient to bring the next numeral on the ratchet (18) into view, it may be adjusted by loosening a screw (15) and shifting the spring. If the numerals are not centered in the cut-out on the cover, adjustment may be made by loosening the screw (11) and shifting the ratchet stop spring (9).

SECTION VI

DISASSEMBLY, INSPECTION, REPAIR, REASSEMBLY AND FINAL TESTS (DEPOTS ONLY)

1. GENERAL.

a. Aircraft Sextants are to be overhauled only at a qualified instrument repair base.

b. The following is a list of special tools required in connection with the work prescribed in this section:

Drawing No.	Description
PQ-3152	Prism Adjusting Hook
PQ-4614	Hex. Nut Wrench
PQ-4616	Plunger Adjusting Screw-driver
PQ-4695	Bushing Bezel Wrench
PQ-6000	Worm Wheel Adjusting Wrench
PQ-6001	Objective Lens Lock Ring Wrench
PQ-6002	Eyepiece Nut Wrench
PQ-6003	Eyepiece Bezel Wrench
PQ-6004	Astigmatizer Lens Nut and Mounting Ring Wrench
PQ-6068	Dowel Pin Jig

2. DISASSEMBLY.

a. TYPE A-5 (1067).

(1) TO REMOVE TELESCOPE ASSEMBLY.

(a) Unsolder the electrical lead, which passes through the telescope body casting, at the contact on the battery rear insulator assembly.

(b) Remove the four screws from the right side plate and one screw from left side plate and carefully lift the telescope assembly from the side plates.

(2) TO REMOVE LEFT SIDE PLATE ASSEMBLY.

(a) Remove the three screws and take out the left side cover assembly.

(b) Unsolder the wires from the switch connection.

(c) Unscrew the two identical nuts under the cover and one screw. Carefully separate the left side from the right side plate.

(3) TO DISASSEMBLE TELESCOPE ASSEMBLY.

(a) TO REMOVE AND SEPARATE BUBBLE AND EYEPIECE PRISM ASSEMBLIES.

1. Rotate the eyepiece prism assembly to an angle of 45° with respect to the telescope body. Unscrew the four screws in top of bubble chamber and the two screws on the left side of the bubble chamber. The eyepiece prism assembly and the bubble assembly may now be removed from the rest of the telescope assembly.

2. Unscrew the four screws in the bottom of the eyepiece prism assembly. Lift off the eyepiece prism assembly and remove the retainers and spring washer.

(b) TO DISASSEMBLE TELESCOPE CASTING ASSEMBLY.

1. Remove the set screw and pull out the objective assembly from the telescope tube.

2. Remove the three cover screws which hold the astigmatizer cover assembly onto the telescope casting. Unhook the astigmatizer spring from the cover assembly and remove the cover assembly.

3. The telescope tube may then be unscrewed from the astigmatizer cover.

4. Remove the knob adjusting screw from the astigmatizer control knob and unscrew the knob. The astigmatizer plate assembly may then be removed.

5. Unscrew the roof prism support screw and remove the roof prism and roof prism support. Care must be taken to prevent chipping the prism during this operation.

6. Unscrew the two screws on the face of the bubble light switch assembly. Unsolder the electrical lead connection at top of switch assembly and the lead which passes through telescope body. This assembly may then be removed.

7. Unscrew the ring light shutter stop assembly which is located on the inside back surface of the telescope casting, and remove the shutter stop assembly.

8. Remove the screw and take out the ring light shutter and washer.

9. Unscrew the ring light bulb. Loosen the set screw and remove the ring light socket.

(c) TO DISASSEMBLE OBJECTIVE LENS ASSEMBLY. - Remove the lens lock ring using the objective lens lock ring wrench (PQ-6001) and take out the diaphragm, lens ring, objective lens and spacing ring. Mark the front surface of the objective lens with a soft wax pencil so that it may be replaced in the same position.

NOTE: Further disassembly will not be undertaken as the horizon shutter assembly and the objective lens mask assembly are staked to the objective lens tube assembly. The objective lens and the spacing ring must be kept together as a unit. The spacing ring has been selected to provide the proper focal length for the objective lens and must not be interchanged with the other objective lenses and spacing rings. If either the elements of the lens or the spacing ring are damaged replace with objective lens and ring assembly (PB-25033-1).

(d) TO REMOVE ASTIGMATIZER GLASS AND LENS.

1. Loosen the set screw on the edge of the astigmatizer plate and remove the astigmatizer lens nut with the wrench (PQ-6004). Take the astigmatizer glass out of the astigmatizer plate.

2. Loosen the set screw and lift out the lens mounting ring. Unscrew the astigmatizer lens nut using wrench (PQ-6004) and remove the spacing ring and astigmatizer lens from the lens mounting ring.

(e) TO DISASSEMBLE EYEPIECE PRISM ASSEMBLY.

1. Remove the three ring retaining screws and one housing retain-

ing screw. The eyepiece including the buffer mounting assembly, lens housing, eyepiece lens and adjusting ring may then be removed.

2. Unscrew the eyepiece bezel with the eyepiece bezel wrench (PQ-6003) and remove the eyepiece lens from the lens housing.

3. Unscrew the four prism housing screws from the sides of the housing which may then be removed. Remove the cork packing and prism.

4. Remove the eyepiece nut with the eyepiece nut wrench (PQ-6002) and take out the mounting spring. Remove the eyepiece buffer mounting from the lens housing.

(f) TO DISASSEMBLE BUBBLE ASSEMBLY.

1. Remove the three screws and take out the spacing ring, the luminous paint ring and the light ring. The small insert is cemented in place and can be pried loose. Scrape carefully the luminous paint which remains on the cell. Remove the tapered plug and drain the fluid from the chamber.

2. The field lens and bubble glass are cemented in place with flake shellac. Place the bubble assembly in alcohol until the shellac is soft enough to unscrew the nuts and then carefully remove the field lens and the bubble bottom glass.

3. Unscrew the diaphragm chamber cover assembly; care should be taken that the nut attached to the cover is kept loose during this operation. The diaphragm is soldered in place by means of soft solder.

(4) TO DISASSEMBLE RIGHT SIDE PLATE ASSEMBLY.

(a) TO DISASSEMBLE INDEX PRISM ASSEMBLY. - Loosen the two adjusting screws from bottom of index prism carrier using prism adjusting hook (PQ-3152) and lift off index prism assembly. The prism is cemented to the prism holder by means of shellac. To remove, place the prism and the holder in alcohol until shellac is dissolved. Removal of the prism will usually involve repainting and resilvering of the prism.

(b) TO DISASSEMBLE WORM SCALE DRUM ASSEMBLY.

1. Unscrew the scale drum cover from the scale drum.

2. Holding the end of the worm gear shaft by means of a pin or a wrench, remove the two nuts. Lift off the scale drum assembly, the twelve stop washers and the spacing washers.

NOTE: If necessary, the upper stop washer may be removed from the scale drum assembly and the lower stop washer from the right side plate by removing the three screws from each washer. In order to locate the lower stop washer correctly upon reassembly, scribe a mark locating the position of the protrusion of the lower stop washer on the plate casting. The same procedure should be followed in marking the position of the upper stop washer in the scale drum.

3. Remove the two screws and take the scale drum brake assembly off the right side plate.

(c) TO REMOVE BATTERY HOLDER.

1. Remove the nut, screw washer, insulating washer and the screw that secure the rear insulator assembly to rear insulator bracket. Unsolder the lead from the battery rear insulator assembly. Take out the rear insulator assembly.

2. Unscrew the three screws and remove rear insulator bracket.

3. Remove the two screws in battery front insulator and lift off the battery front insulator assembly with the two leads.

4. Unscrew the three screws and remove the front insulator bracket.

5. Remove the battery spring support which carries the battery retaining spring.

(d) TO REMOVE SPRING CONTACT ASSEMBLY.

1. Unsolder the electrical connection and remove the wire and wire protection tube.

2. Remove the two screws and lift off the washers, bushings, spring contact assembly and contact insulation.

NOTE: The contact spring is soldered to the contact plate.

3. If necessary, the two spacing pillars may be removed from the right side plate.

(e) TO REMOVE AND DISASSEMBLE RIGHT SIDE COVER ASSEMBLY.

1. Remove the three screws that secure the right side cover to right side plate and take out the cover.

2. Remove the four screws and lift off the celluloid card.

3. Unscrew the two screws and remove the worm wheel index.

4. The glass is cemented to the right side cover and may be removed by heating the plate to soften the shellac.

NOTE: The worm wheel assembly, worm assembly and plunger must not be disassembled as this will destroy the accuracy of the instrument.

(5) TO DISASSEMBLE LEFT SIDE PLATE ASSEMBLY.

NOTE: The cover assembly was previously removed when the left side plate assembly was separated from the right side plate assembly.

(a) Loosen the two adjusting screws with prism adjusting hook (PQ-3152) and take the horizon prism holder assembly off the carrier.

NOTE: The horizon prism is cemented to the holder with shellac and, if necessary, can be removed by dissolving the shellac in alcohol. This will usually involve repainting and resilvering of the prism.

(b) Remove the nut with the hex nut wrench (PQ-4614), and take out the lock-washer, washer and the horizon prism carrier.

(c) Remove the two mounting screws and take the adjusting plate out of the left side plate. The two adjusting screws

may be removed from the adjusting plate if necessary.

(d) Remove the screw that holds the shade glass assembly, to the left side plate and take out the assembly and the spacer washer.

NOTE: The shade glasses must not be removed from the shade glass holder as they are cemented in place.

(e) Remove the two screws and take the two insulating washers, contact spring assembly, contact spring insulator, stationary contact spring assembly and the insulating bushing out of the left side plate. Remove the switch button.

NOTE: The contact spring assemblies will not be further disassembled as the contacts are riveted to the springs.

b. TYPE A-7 (A-5A) AVERAGING DEVICE (BJ-1).

(1) TO REMOVE AVERAGING DEVICE FROM SEXTANT. - Place the sextant on a bench with the averaging device facing upward. Loosen the four averaging device adjusting screws and carefully lift the device from the sextant.

(2) TO REMOVE SEGMENT ASSEMBLY FROM COVER.

NOTE: The segment assembly is mounted on the cover and on lapped taper bearings. Hence, it should be handled very carefully to prevent injury to the bearing surfaces.

(a) Loosen the brake spring adjusting screw sufficiently to slaken the tension of the brake spring.

(b) The lock lever must be removed as it hinders further disassembly. This is accomplished by unscrewing the lock lever stud and removing the lever.

(c) The segment assembly can be removed from the cover by loosening and removing vernier retaining stud and stud locking nut. Place the device face down, pull the brake spring away from the cover, and carefully lift the segment assembly out of the device. Take out the lock lever stud spacer.

(3) TO DISASSEMBLE SEGMENT ASSEMBLY.

NOTE: The vernier shoe assembly, attached to the segment assembly by the spring pin, should not be removed unless for replacement. See paragraph 3., this section.

(a) To remove brake spring, unscrew two brake spring screws.

(b) The segment stop pins may be unscrewed from the segment.

(4) TO REMOVE DIAL AND VERNIER.

(a) To remove the dial, remove three dial screws and adjusting screw housing, together with adjusting screws.

(b) The vernier and vernier bearing may be lifted off, the vernier retaining stud already removed. These parts may be separated by removing the three vernier bearing screws. The vernier and the bearing are machined to fit as a unit. They must be kept together.

(c) The vernier spring is now free,

(5) TO REMOVE VERNIER STOP LEVER ASSEMBLY. - Unscrew the stop lever stud. Remove the vernier stop lever assembly and stop lever washer from the cover. The vernier stop lever assembly cannot be further disassembled.

(6) TO REMOVE AND DISASSEMBLE SEGMENT STOP SCREW SUPPORT.

(a) Remove support and locking screws. The support can be separated from the cover.

(b) Unscrew segment stop screw from the support. To remove adjusting knob from the segment stop screw, loosen the adjusting knob stud and slide knob off the segment stop screw.

g. TYPE A-7 (3003-A and 3003-B).

(1) TO REMOVE AND DISASSEMBLE BJ-4 AVERAGING DEVICE (Refer to figure 22).

INDEXED PARTS LIST

INDEX NO.	PART NO.
1	PB-23410-1
2	PB-23411-1
3	PB-23403-1
4	PB-23413-1
5	FF11-0-205E
6	PC-23418-1
7	TP-0-7005SS
8	PB-23406-1
9	PB-23407-1
10	PC-23417-1
11	FF11-0-202½
12	PB-23416-1
13	PB-24654-1
14	FF11-0-205SS
15	FF11-0-202
16	PB-23402-1
17	N-0-2
18	PB-23404-1
19	PB-23408-1
20	PB-23412-1
21	PB-23446-1
22	PB-23401-1
23	PC-23426-1
24	PB-23438-1
25	PB-23415-1
26	FF11-0-102E
27	B-0-3SS
28	PB-23405-1
29	PB-23447-1
30	FF11-0-210E

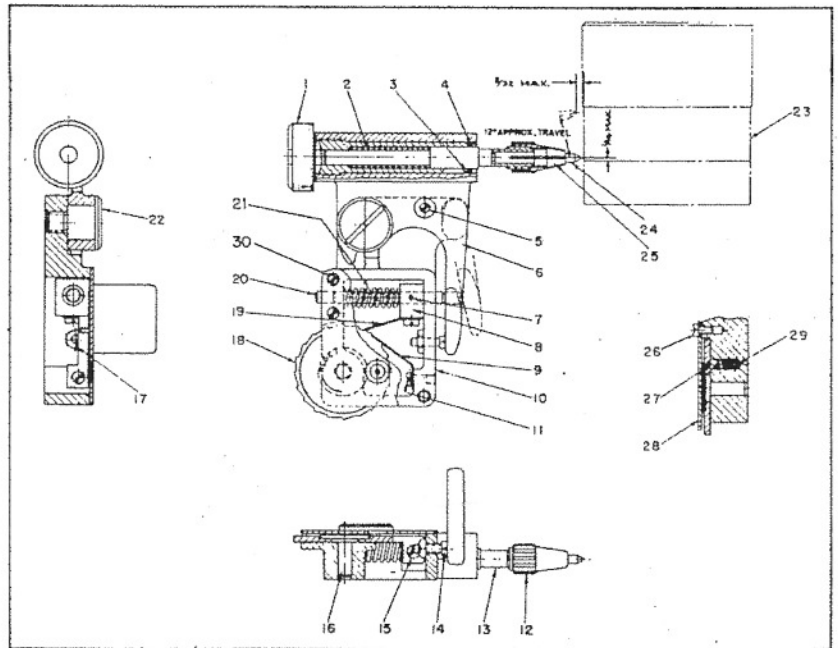

NOTE: Part Numbers Are Identical For 3003-A and 3003-B.

Figure 22 - Sectional View - Averaging Device - Pioneer BJ-4