

3. Reassemble the new bubble assembly to the sextant by reversing steps 1. and 2., this section.

b. ADJUSTMENT OF BJ-4 AVERAGING DEVICE (Refer to figure 24).

(1) It may be necessary for smooth accurate operation of the BJ-4 Averaging Device used on Type A-7 (Pioneer 3003-A and 3003-B), to adjust the pencil assembly for proper travel and pressure of the pencil (24) against the micrometer drum (23). Adjustment of the travel is accomplished by removing the cover screw (2f) and the cover (28), and loosening the nut (17) on the adjusting screw (14). By means of the adjusting screw, adjust the travel of the pencil assembly to that shown in the figure. Lock the adjusting

screw (14) in position with the nut (17) and replace the cover and cover screw.

(2) To permit removal of the pencil lead, back out the pencil assembly by means of the knurled knob (1). Sharpen the point if necessary, and replace pencil assembly into the trigger (6). Adjust the pencil assembly so that a fine legible line is marked on the micrometer drum (23) when the trigger (6) is operated.

(3) If the tension on the ratchet spring (19) is insufficient to bring the next numeral on the ratchet (18) into view, it may be adjusted by loosening a screw (15) and shifting the spring. If the numerals are not centered in the cut-out on the cover, adjustment may be made by loosening the screw (11) and shifting the ratchet stop spring (9).

SECTION VI

DISASSEMBLY, INSPECTION, REPAIR, REASSEMBLY AND FINAL TESTS (DEPOTS ONLY)

1. GENERAL.

a. Aircraft Sextants are to be overhauled only at a qualified instrument repair base.

b. The following is a list of special tools required in connection with the work prescribed in this section:

Drawing No.	Description
PQ-3152	Prism Adjusting Hook
PQ-4614	Hex. Nut Wrench
PQ-4616	Plunger Adjusting Screw-driver
PQ-4695	Bushing Bezel Wrench
PQ-6000	Worm Wheel Adjusting Wrench
PQ-6001	Objective Lens Lock Ring Wrench
PQ-6002	Eyepiece Nut Wrench
PQ-6003	Eyepiece Bezel Wrench
PQ-6004	Astigmatizer Lens Nut and Mounting Ring Wrench
PQ-6068	Dowel Pin Jig

2. DISASSEMBLY.

a. TYPE A-5 (1067).

(1) TO REMOVE TELESCOPE ASSEMBLY.

(a) Unsolder the electrical lead, which passes through the telescope body casting, at the contact on the battery rear insulator assembly.

(b) Remove the four screws from the right side plate and one screw from left side plate and carefully lift the telescope assembly from the side plates.

(2) TO REMOVE LEFT SIDE PLATE ASSEMBLY.

(a) Remove the three screws and take out the left side cover assembly.

(b) Unsolder the wires from the switch connection.

(c) Unscrew the two identical nuts under the cover and one screw. Carefully separate the left side from the right side plate.

(3) TO DISASSEMBLE TELESCOPE ASSEMBLY.

(a) TO REMOVE AND SEPARATE BUBBLE AND EYEPIECE PRISM ASSEMBLIES.

1. Rotate the eyepiece prism assembly to an angle of 45° with respect to the telescope body. Unscrew the four screws in top of bubble chamber and the two screws on the left side of the bubble chamber. The eyepiece prism assembly and the bubble assembly may now be removed from the rest of the telescope assembly.

2. Unscrew the four screws in the bottom of the eyepiece prism assembly. Lift off the eyepiece prism assembly and remove the retainers and spring washer.

(b) TO DISASSEMBLE TELESCOPE CASTING ASSEMBLY.

1. Remove the set screw and pull out the objective assembly from the telescope tube.

2. Remove the three cover screws which hold the astigmatizer cover assembly onto the telescope casting. Unhook the astigmatizer spring from the cover assembly and remove the cover assembly.

3. The telescope tube may then be unscrewed from the astigmatizer cover.

4. Remove the knob adjusting screw from the astigmatizer control knob and unscrew the knob. The astigmatizer plate assembly may then be removed.

5. Unscrew the roof prism support screw and remove the roof prism and roof prism support. Care must be taken to prevent chipping the prism during this operation.

6. Unscrew the two screws on the face of the bubble light switch assembly. Unsolder the electrical lead connection at top of switch assembly and the lead which passes through telescope body. This assembly may then be removed.

7. Unscrew the ring light shutter stop assembly which is located on the inside back surface of the telescope casting, and remove the shutter stop assembly.

8. Remove the screw and take out the ring light shutter and washer.

9. Unscrew the ring light bulb. Loosen the set screw and remove the ring light socket.

(c) TO DISASSEMBLE OBJECTIVE LENS ASSEMBLY. - Remove the lens lock ring using the objective lens lock ring wrench (PQ-6001) and take out the diaphragm, lens ring, objective lens and spacing ring. Mark the front surface of the objective lens with a soft wax pencil so that it may be replaced in the same position.

NOTE: Further disassembly will not be undertaken as the horizon shutter assembly and the objective lens mask assembly are staked to the objective lens tube assembly. The objective lens and the spacing ring must be kept together as a unit. The spacing ring has been selected to provide the proper focal length for the objective lens and must not be interchanged with the other objective lenses and spacing rings. If either the elements of the lens or the spacing ring are damaged replace with objective lens and ring assembly (PB-25033-1).

(d) TO REMOVE ASTIGMATIZER GLASS AND LENS.

1. Loosen the set screw on the edge of the astigmatizer plate and remove the astigmatizer lens nut with the wrench (PQ-6004). Take the astigmatizer glass out of the astigmatizer plate.

2. Loosen the set screw and lift out the lens mounting ring. Unscrew the astigmatizer lens nut using wrench (PQ-6004) and remove the spacing ring and astigmatizer lens from the lens mounting ring.

(e) TO DISASSEMBLE EYEPIECE PRISM ASSEMBLY.

1. Remove the three ring retaining screws and one housing retain-

ing screw. The eyepiece including the buffer mounting assembly, lens housing, eyepiece lens and adjusting ring may then be removed.

2. Unscrew the eyepiece bezel with the eyepiece bezel wrench (PQ-6003) and remove the eyepiece lens from the lens housing.

3. Unscrew the four prism housing screws from the sides of the housing which may then be removed. Remove the cork packing and prism.

4. Remove the eyepiece nut with the eyepiece nut wrench (PQ-6002) and take out the mounting spring. Remove the eyepiece buffer mounting from the lens housing.

(f) TO DISASSEMBLE BUBBLE ASSEMBLY.

1. Remove the three screws and take out the spacing ring, the luminous paint ring and the light ring. The small insert is cemented in place and can be pried loose. Scrape carefully the luminous paint which remains on the cell. Remove the tapered plug and drain the fluid from the chamber.

2. The field lens and bubble glass are cemented in place with flake shellac. Place the bubble assembly in alcohol until the shellac is soft enough to unscrew the nuts and then carefully remove the field lens and the bubble bottom glass.

3. Unscrew the diaphragm chamber cover assembly; care should be taken that the nut attached to the cover is kept loose during this operation. The diaphragm is soldered in place by means of soft solder.

(4) TO DISASSEMBLE RIGHT SIDE PLATE ASSEMBLY.

(a) TO DISASSEMBLE INDEX PRISM ASSEMBLY. - Loosen the two adjusting screws from bottom of index prism carrier using prism adjusting hook (PQ-3152) and lift off index prism assembly. The prism is cemented to the prism holder by means of shellac. To remove, place the prism and the holder in alcohol until shellac is dissolved. Removal of the prism will usually involve repainting and resilvering of the prism.

(b) TO DISASSEMBLE WORM SCALE DRUM ASSEMBLY.

1. Unscrew the scale drum cover from the scale drum.

2. Holding the end of the worm gear shaft by means of a pin or a wrench, remove the two nuts. Lift off the scale drum assembly, the twelve stop washers and the spacing washers.

NOTE: If necessary, the upper stop washer may be removed from the scale drum assembly and the lower stop washer from the right side plate by removing the three screws from each washer. In order to locate the lower stop washer correctly upon reassembly, scribe a mark locating the position of the protrusion of the lower stop washer on the plate casting. The same procedure should be followed in marking the position of the upper stop washer in the scale drum.

3. Remove the two screws and take the scale drum brake assembly off the right side plate.

(c) TO REMOVE BATTERY HOLDER.

1. Remove the nut, screw washer, insulating washer and the screw that secure the rear insulator assembly to rear insulator bracket. Unsolder the lead from the battery rear insulator assembly. Take out the rear insulator assembly.

2. Unscrew the three screws and remove rear insulator bracket.

3. Remove the two screws in battery front insulator and lift off the battery front insulator assembly with the two leads.

4. Unscrew the three screws and remove the front insulator bracket.

5. Remove the battery spring support which carries the battery retaining spring.

(d) TO REMOVE SPRING CONTACT ASSEMBLY.

1. Unsolder the electrical connection and remove the wire and wire protection tube.

2. Remove the two screws and lift off the washers, bushings, spring contact assembly and contact insulation.

NOTE: The contact spring is soldered to the contact plate.

3. If necessary, the two spacing pillars may be removed from the right side plate.

(e) TO REMOVE AND DISASSEMBLE RIGHT SIDE COVER ASSEMBLY.

1. Remove the three screws that secure the right side cover to right side plate and take out the cover.

2. Remove the four screws and lift off the celluloid card.

3. Unscrew the two screws and remove the worm wheel index.

4. The glass is cemented to the right side cover and may be removed by heating the plate to soften the shellac.

NOTE: The worm wheel assembly, worm assembly and plunger must not be disassembled as this will destroy the accuracy of the instrument.

(5) TO DISASSEMBLE LEFT SIDE PLATE ASSEMBLY.

NOTE: The cover assembly was previously removed when the left side plate assembly was separated from the right side plate assembly.

(a) Loosen the two adjusting screws with prism adjusting hook (PQ-3152) and take the horizon prism holder assembly off the carrier.

NOTE: The horizon prism is cemented to the holder with shellac and, if necessary, can be removed by dissolving the shellac in alcohol. This will usually involve repainting and resilvering of the prism.

(b) Remove the nut with the hex nut wrench (PQ-4614), and take out the lock-washer, washer and the horizon prism carrier.

(c) Remove the two mounting screws and take the adjusting plate out of the left side plate. The two adjusting screws

may be removed from the adjusting plate if necessary.

(d) Remove the screw that holds the shade glass assembly, to the left side plate and take out the assembly and the spacer washer.

NOTE: The shade glasses must not be removed from the shade glass holder as they are cemented in place.

(e) Remove the two screws and take the two insulating washers, contact spring assembly, contact spring insulator, stationary contact spring assembly and the insulating bushing out of the left side plate. Remove the switch button.

NOTE: The contact spring assemblies will not be further disassembled as the contacts are riveted to the springs.

b. TYPE A-7 (A-5A) AVERAGING DEVICE (BJ-1).

(1) TO REMOVE AVERAGING DEVICE FROM SEXTANT. - Place the sextant on a bench with the averaging device facing upward. Loosen the four averaging device adjusting screws and carefully lift the device from the sextant.

(2) TO REMOVE SEGMENT ASSEMBLY FROM COVER.

NOTE: The segment assembly is mounted on the cover and on lapped taper bearings. Hence, it should be handled very carefully to prevent injury to the bearing surfaces.

(a) Loosen the brake spring adjusting screw sufficiently to slaken the tension of the brake spring.

(b) The lock lever must be removed as it hinders further disassembly. This is accomplished by unscrewing the lock lever stud and removing the lever.

(c) The segment assembly can be removed from the cover by loosening and removing vernier retaining stud and stud locking nut. Place the device face down, pull the brake spring away from the cover, and carefully lift the segment assembly out of the device. Take out the lock lever stud spacer.

(3) TO DISASSEMBLE SEGMENT ASSEMBLY.

NOTE: The vernier shoe assembly, attached to the segment assembly by the spring pin, should not be removed unless for replacement. See paragraph 3., this section.

(a) To remove brake spring, unscrew two brake spring screws.

(b) The segment stop pins may be unscrewed from the segment.

(4) TO REMOVE DIAL AND VERNIER.

(a) To remove the dial, remove three dial screws and adjusting screw housing, together with adjusting screws.

(b) The vernier and vernier bearing may be lifted off, the vernier retaining stud already removed. These parts may be separated by removing the three vernier bearing screws. The vernier and the bearing are machined to fit as a unit. They must be kept together.

(c) The vernier spring is now free,

(5) TO REMOVE VERNIER STOP LEVER ASSEMBLY. - Unscrew the stop lever stud. Remove the vernier stop lever assembly and stop lever washer from the cover. The vernier stop lever assembly cannot be further disassembled.

(6) TO REMOVE AND DISASSEMBLE SEGMENT STOP SCREW SUPPORT.

(a) Remove support and locking screws. The support can be separated from the cover.

(b) Unscrew segment stop screw from the support. To remove adjusting knob from the segment stop screw, loosen the adjusting knob stud and slide knob off the segment stop screw.

2. TYPE A-7 (3003-A and 3003-B).

(1) TO REMOVE AND DISASSEMBLE BJ-4 AVERAGING DEVICE (Refer to figure 22).

INDEXED PARTS LIST

INDEX NO.	PART NO.
1	PB-23410-1
2	PB-23411-1
3	PB-23403-1
4	PB-23413-1
5	FF11-0-205E
6	PC-23418-1
7	TP-0-7005SS
8	PB-23406-1
9	PB-23407-1
10	PC-23417-1
11	FF11-0-202½
12	PB-23416-1
13	PB-24654-1
14	FF11-0-205SS
15	FF11-0-202
16	PB-23402-1
17	N-0-2
18	PB-23404-1
19	PB-23408-1
20	PB-23412-1
21	PB-23446-1
22	PB-23401-1
23	PC-23426-1
24	PB-23438-1
25	PB-23415-1
26	FF11-0-102E
27	B-0-3SS
28	PB-23405-1
29	PB-23447-1
30	FF11-0-210E

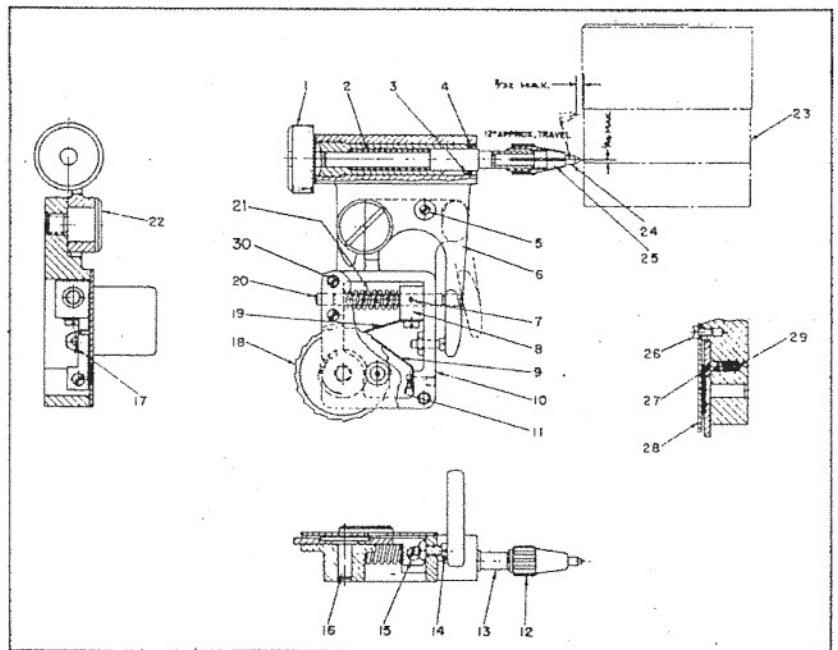

NOTE: Part Numbers Are Identical For 3003-A and 3003-B.

Figure 22 - Sectional View - Averaging Device - Pioneer BJ-4

(a) Place the sextant on a bench in its normal upright position. Loosen the two screws (30) one each in the upper left and lower right corners, respectively, of the cover.

(b) Press the trigger (6) backward, and holding the trigger in this position, loosen the screw (5) on the base plate through the cutout in the trigger. Lift the device from the sextant.

(c) Remove the pivot stud (22) and separate the trigger operated pencil assembly (6) from the base plate (10).

(d) By means of the knurled end, unscrew the pencil assembly and back it out of the trigger (6).

(e) Unscrew the sleeve (12) from the sleeve and pin assembly (13) and remove the pencil lead (24) and the collet (25).

(f) Remove the snap ring (4) and take the sleeve and pin assembly and spring (2) out of the pencil housing (1).

NOTE: Do not remove the pin (3) from the sleeve and pin assembly as it is soldered in place.

(g) Remove the screw (26) holding the cover onto the base plate (10). Take out the cover (28), ratchet (18), ratchet pivot (16), ball (27) and detent spring (29).

(h) Remove the screw (11) and lock-washer and take the ratchet stop spring (9) out of the base plate.

(i) Remove the screw (14) and the nut (17) as they hinder the removal of the ratchet spring.

(j) Remove the screw (15) and lock-washer and take the ratchet spring (19) off the stop (8).

(k) Hold the stop (8) securely and remove the taper pin (7) using a suitable punch. Slide the trip pin (20) out of the base plate (10) and take out the stop (8) and the trigger spring (21).

(2) TO REMOVE TELESCOPE ASSEMBLY. - Remove the four screws from the right side plate and one screw from the left side plate. Carefully lift the telescope assembly from the side plates.

(3) TO SEPARATE LEFT AND RIGHT SIDE PLATE ASSEMBLIES (Refer to figure 23).

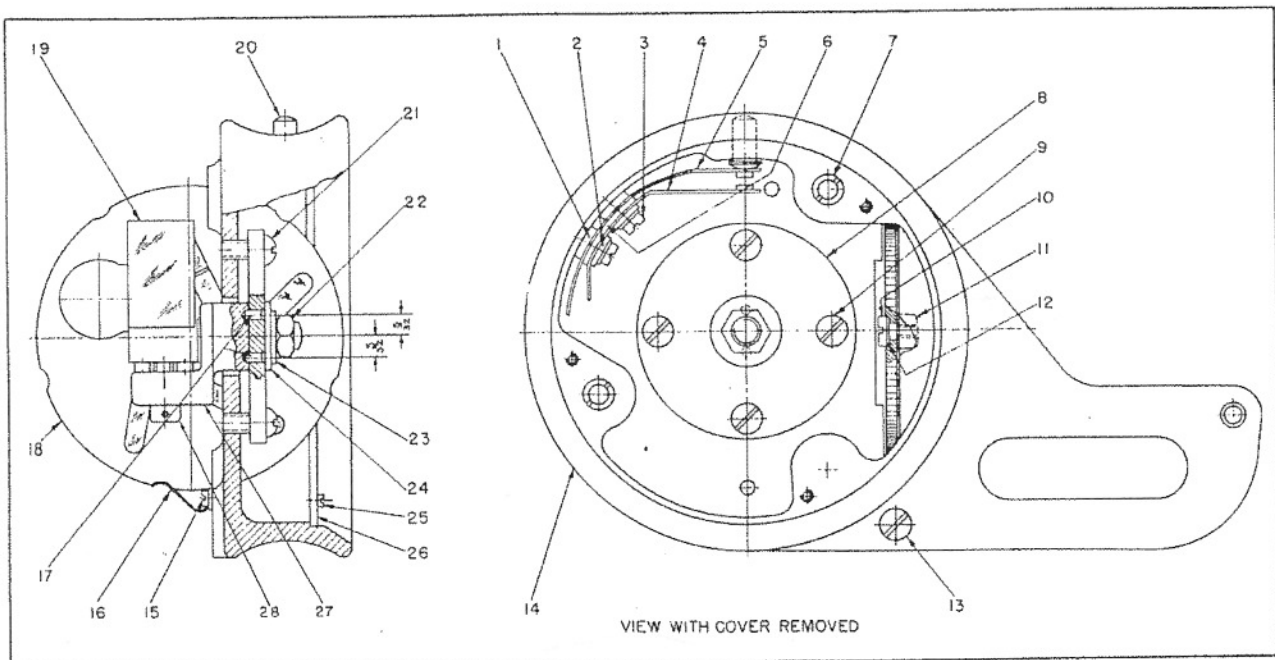

Figure 23 - Left Side - Sectional View - Aircraft Sextant - Type A-7 (3003-A, 3003-B)

(a) Remove the three screws (25) and lift the left side cover assembly (26) out of the left side plate (14).

(b) Unsolder the two wires from the contact spring assemblies (4 and 5).

(c) Remove the two nuts (7) and the screw (13) and separate the left side plate assembly from the right side plate assembly.

NOTE: Guide the wires through the holes in the left side plate (14) while separating the assemblies.

(4) TO DISASSEMBLE TELESCOPE ASSEMBLY. (Refer to figure 24).

(a) TO REMOVE AND SEPARATE BUBBLE AND EYEPIECE PRISM ASSEMBLIES.

1. Rotate the eyepiece prism assembly to an angle of 45° with respect to

the telescope body. Remove the four screws (52) in top of bubble chamber and two screws (82) on the left side of bubble chamber. The eyepiece prism assembly and the bubble assembly may now be removed from the rest of the telescope assembly.

2. With the eyepiece prism assembly still in a 45° position, remove the four screws (69) which secure the eyepiece prism assembly to the retainers (51) at bottom of the assembly. Remove the assembly, the two retainers and the spring washer from the top of the bubble assembly.

(b) TO DISASSEMBLE TELESCOPE CASTING ASSEMBLY.

1. Remove the set screw (37) and pull the objective lens assembly out of the astigmatizer cover assembly (92).

INDEXED PARTS LIST

FOR LEFT SIDE - AIRCRAFT SEXTANT (3003-A, 3003-B)

(SEE Fig. 23)

INDEX NO.	PART NAME	ARMY TYPE A-7 PIONEER TYPE 3003-A	ARMY TYPE A-7 PIONEER TYPE 3003-B
		PART NO.	PART NO.
1	Bushing - Insulating	PB-9281	
2	Washer - Insulating	PB-9278	
3	Screw	Fil-0-204	
4	Spring Assembly - Stationary Contact	PB-9605	
5	Spring Assembly - Contact	PB-9604	
6	Insulator - Contact Spring	PB-9280	
7	Nut	342-8	
8	Plate - Adjusting	342-11	
9	Screw - Horizon Adjusting	342-129	
10	Screw - Shade Holder	342-6	
11	Washer - Spacer	PB-23065-1	
12	Shim	PB-24662-*	
13	Screw - Battery Spring Support	PB-9747	
14	Plate - Left Side	PD-9248	
15	Screw	Fil-0-102B	
16	Spring - Shade Holder	PB-10698	
17	Pin - Dowel	PB-9239	
18	Shade Assembly	PB-9865	
19	Prism - Horizon	PB-9660	
20	Button - Switch	PB-9277	
21	Screw	R-0-606	
22	Nut	N-0-10	
23	Lockwasher	LW-0-10	
24	Washer	W-0-10	
25	Screw	Fil-0-202BL	
26	Cover Assembly - Left Side	PB-10023	
27	Carrier - Horizon Prism	PC-9214	
28	Screw - Horizon Adjusting	342-129	

* See Parts List For Dash Numbers
NOTE: Part Numbers Listed In The First Column Are Identical For Each Instrument Unless Otherwise Indicated.

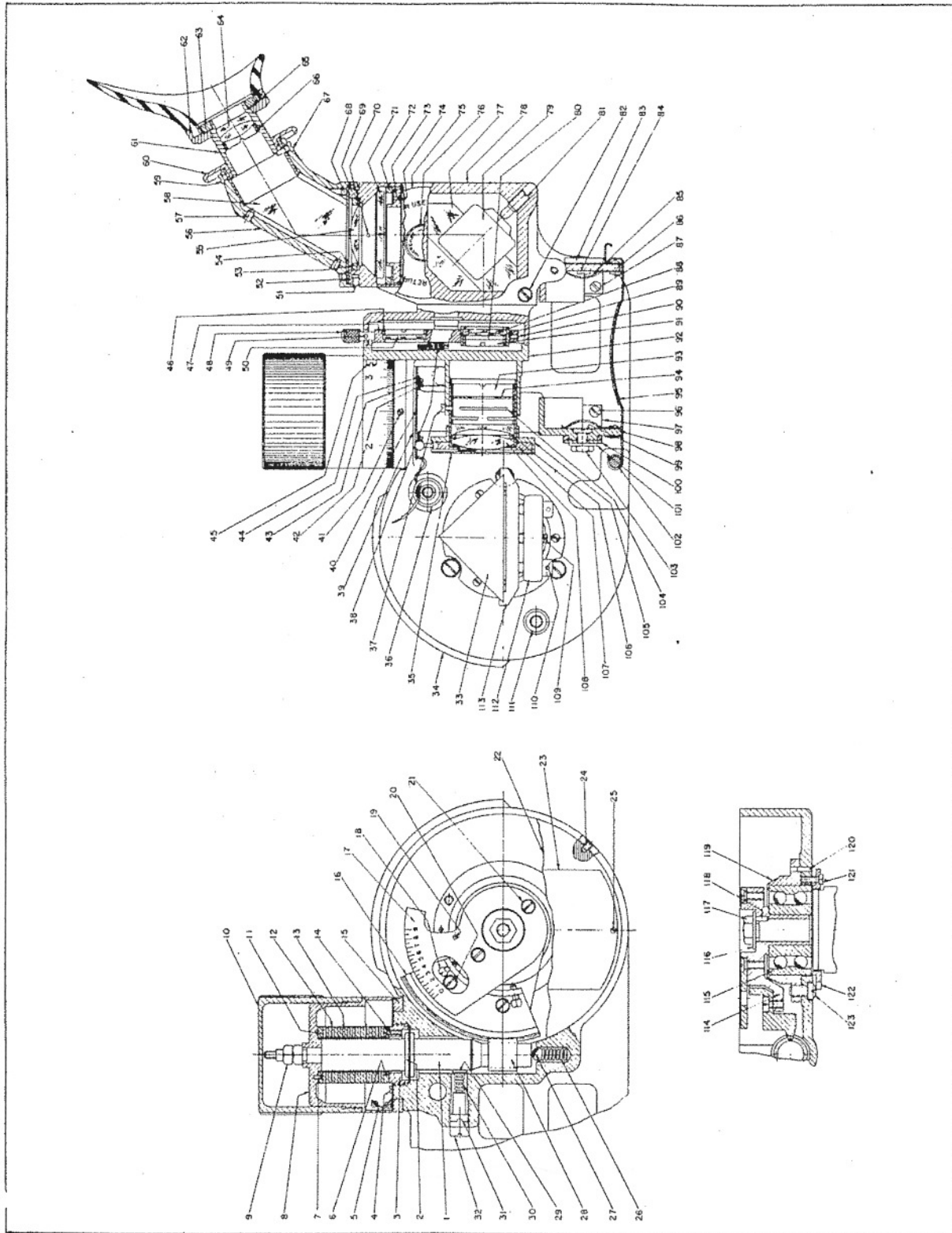

Figure 24 - Right Side - Sectional View - Aircraft Sextant -
Type A-7 (3003-A, 3003-B)

RESTRICTED

T. O. No. 05-35-4

INDEXED PARTS LIST

FOR RIGHT SIDE - AIRCRAFT SEXTANT (3003-A, 3003-B)
(See Fig. 24)

INDEX NO.	PART NAME	ARMY TYPE	ARMY TYPE
		PART NO.	PART NO.
1	Bushing and Worm Assembly	PC-20637	
2	Ring - Seating	PB-20632	
3	Bezel - Worm bushing	PB-20624-2	
4	Screw	F11-0-002	
5	Brake Assembly - Scale drum	PB-10775	
6	Washer - Lower stop	PB-20629	
7	Screw	F-0-003	
8	Drum - Worm scale	PC-23425-1	
9	Nut	N-0-8	
10	Cover - Scale drum	PC-23426-1	
11	Washer - Upper stop	PB-20627	
12	Washer - Spacing	PB-20625	
13	Washer - Intermediate stop	PB-20628	
14	Screw	F-0-002	
15	Ring - Lubber line	PB-9274	
16	Wheel - Worm	PB-20792	
17	Dial - Worm wheel	PC-23482-1	
18	Screw - Adjusting	251-152	
19	Dowel	PB-5010	
20	Screw - Locking	PB-9490	
21	Screw - Dial	PB-22862-1	
22	Cover - Right side	342-4	
23	Card - Celluloid	342-63B	
24	Screw	342-154	
25	Screw	F-0-002	
26	Spring - Worm shaft plunger	PB-9254	
27	Ball - Steel	B-0-6S	
28	Worm	PC-20636	
29	Plunger - Worm shaft	PB-9253	
30	Spring - Worm shaft plunger	PB-9254	
31	Screw - Worm shaft plunger	PB-9252	
32	Plug - Worm shaft plunger	PB-11324	
33	Prism - Index	PB-9659	
34	Plate - Right side	PD-22819-1	
35	Mask Assembly - Objective lens	PB-9232	
36	Tube - Wire protection	PB-9929-3	
37	Screw	F11-0-202BL	F11-0-203BL
38	Spring - Astigmatizer	PB-9243	
39	Insulation - Contact	PB-9921	
40	Contact Assembly - Spring	PB-11100	
41	Screw - Lubber line ring lock	PB-9273	
42	Screw	F11-0-002B	
43	Washer	W-0-0B	
44	Bushing	342-126	
45	Screw	F11-0-210B	F11-0-207B
46	Nut - Astigmatizer lens	PB-3805	
47	Plate Assembly - Astigmatizer	PB-9567-1	
48	Knob - Astigmatizer	PB-9245	
49	Screw - Astigmatizer knob adjusting	PB-11032	
50	Glass - Astigmatizer	PB-9241	
51	Retainer	PB-23583-1	
52	Screw	F11-0-409B	
53	Ring - Lens retaining	PB-9219	
54	Plate - Prism retaining	PB-12476	
55	Lens - Etched field	PB-20142-1	
56	Carrier Assembly - Eyepiece prism	PD-18330-1	
57	Screw - Set	OS-0-203B	
58	Prism - Eyepiece	PB-12472-1	
59	Screw - Short retaining	PB-9212-1	
60	Ring - Adjusting	PB-9210	
61	Housing - Eyepiece lens	PB-9207	

NOTE: Part Numbers Listed In the First Column Are Identical
For Each Instrument Unless Otherwise Indicated.

Revised 10-10-42

- 31 -

RESTRICTED

RESTRICTED

T. O. No. 05-35-4

INDEXED PARTS LIST

FOR RIGHT SIDE - AIRCRAFT SEXTANT (3003-A, 3003-B)
(See Fig. 24)

ARMY TYPE
A-7
PIONEER TYPE
3003-A

ARMY TYPE
A-7
PIONEER TYPE
3003-B

INDEX	PART NAME	PART NO.	PART NO.
62	Mounting Assembly - Eyepiece buffer	PB-9554-1	
63	Nut - Eyepiece	342-29	
64	Lens - Eyepiece	342-35B	
65	Spring - Mounting	PB-9244	
66	Bezel - Eyepiece	342-82B	
67	Screw - Long retaining	PB-9211-1	
68	Screw	F-0-102B	
69	Screw	F-0-203B	
70	Plug - Bubble chamber	PB-11590	
71	Bottom - Bubble	PB-9221	
72	Ring - Glass retainer	PB-9220	
73	Ring	PB-20614	
74	Screw	F-0-102BL	
75	Cap Assembly - Diaphragm	PB-23598-3	
76	Nut - Bubble chamber	PB-23597-1	
77	Prism - Roof	342-86	
78	Body - Telescope	PD-22824-1	PD-24246-1
79	Support - Prism	PB-9235	
80	Ring - Spacing	PB-8213	
81	Screw - Prism	342-88B	
82	Screw	F11-0-403BL	
83	Bracket - Front insulator	PB-9650	
84	Screw	F11-0-202B	
85	Contact - Battery front	PB-9654	
86	Insulator Assembly - Battery front	PB-9923-2	
87	Screw	FF11-0-303N	
88	Lens - Astigmatizer	342-67	
89	Ring - Astigmatizer mounting	342-119	
90	Screw - Lock	PB-9242	
91	Nut - Astigmatizer lens	PB-3805	
92	Cover Assembly - Astigmatizer	PB-10019	PC-23956-1
93	Ring - Lens	PB-6180	
94	Diaphragm	PB-11445	
95	Spring Assembly - Retaining	PB-10563	
96	Screw	FF11-0-303B	
97	Bracket - Rear insulator	PB-9652	
98	Insulator Assembly - Battery rear	PB-9924-1	
99	Screw - Insulator	PB-9655	
100	Washer - Insulating	PB-9752	
101	Washer - Screw	PB-9751	
102	Support - Battery spring	PB-9997	
103	Nut	N-0-4B	
104	Ring - Lens	PB-6179	
105	Tube Assembly - Objective lens	PB-9284	
106	Ring - Spacing	PB-7983	
107	Shutter Assembly - Horizon	PB-9794	
108	Lens - Objective	PB-6753	
109	Pivot - Regulating	PB-9218	
110	Screw - Prism adjusting	PB-9689	
111	Pillar - Spacing	PB-9927	
112	Carrier - Index prism	PC-23507-1	
113	Holder - Index prism	PB-9216	
114	Support - Worm wheel	PC-23453-1	
115	Bearing - Worm wheel support	PB-23434-1	
116	Washer	342-175	
117	Nut	N-0-10BN	
118	Pin - Dowel	PB-9239	
119	Housing - Bearing	PC-23452-1	
120	Pin - Dowel	PB-19748	
121	Screw	FF11-0-103B	
122	Ring - Bearing retainer	PB-23783-1	
123	Screw	F11-0-603B	

NOTE: Part Numbers Listed In The First Column Are Identical
For Each Instrument Unless Otherwise Indicated.

2. Remove the three cover screws (45) which hold the astigmatizer cover assembly onto the telescope body (78). Remove the cover assembly. Unhook the spring (38) attached to the pin on the cover assembly and similar pin on the astigmatizer plate assembly.

NOTE: The telescope tube on type 3003-A is a shrink fit into the astigmatizer and cannot be removed. On type 3003-B, the telescope tube and astigmatizer cover are die cast as a unit.

3. Remove the astigmatizer plate assembly (42) with the astigmatizer lens and glass from the pivot bushing in the telescope body.

NOTE: If necessary, the astigmatizer knob (48) with the knob adjusting screw (49) may be removed from the astigmatizer plate assembly by unscrewing it.

4. Remove the prism screw (81) and take the body prism (77) and the prism support (79) out of the telescope body (78).

NOTE: Care must be taken to prevent damaging the prism during this operation.

(c) TO REMOVE ASTIGMATIZER LENS AND GLASS.

1. Loosen the set screw (90) on the edge of the astigmatizer plate and remove the astigmatizer lens nut (46) using lens nut wrench (PQ-6004). The astigmatizer glass (50) may then be removed.

2. Remove the set screw (90) and lift out the mounting ring (89) in which the lens is held. Remove the astigmatizer lens nut (91) with lens nut wrench (PQ-6004) and take out the spacing ring (80) and astigmatizer lens (88).

(d) TO DISASSEMBLE OBJECTIVE LENS ASSEMBLY. - Remove the lens lock ring (93) with lens lock ring wrench (PQ-6001) and take out the diaphragm (94), lens ring (104), objective lens (108) and spacing ring (106). Mark the front surface of the objective lens with soft wax pencil so that it may be replaced in the same position.

NOTE: Further disassembly will not be undertaken as the horizon shutter assembly (107) and the objective lens mask assembly (35) are staked to the objective lens tube assembly (105). The objective lens and the spacing ring must be kept together as a unit. The spacing ring has been selected to provide the proper focal length for the objective lens and must not be interchanged with other objective lenses and spacing rings. If either the elements of the lens or the spacing ring are damaged replace with the objective lens and ring assembly (PB-25033-1).

(e) TO DISASSEMBLE EYEPIECE PRISM ASSEMBLY.

1. Remove the three short retaining screws (59) and one long retaining screw (67) from the eyepiece prism carrier assembly. Remove the eyepiece lens ring and housing assembly and the buffer mounting assembly from the eyepiece prism carrier assembly.

2. Unscrew the eyepiece bezel (66) from the inside of the lens housing with the eyepiece bezel wrench (PQ-6003) and remove the eyepiece lens (64).

3. Remove the eyepiece nut (63) from the buffer mounting assembly (62) using eyepiece nut wrench (PQ-6002) and take out the mounting spring (65). Remove the eyepiece buffer mounting assembly from the eyepiece lens ring and housing assembly.

CAUTION: Do not remove the adjusting ring (60) from the eyepiece lens housing (61) as these parts are matched. If either of these parts is damaged replace with a new matched eyepiece lens ring and housing assembly.

4. Loosen the six set screws (57) in the prism carrier (56). Remove four plate screws (68) from the bottom of the prism carrier assembly. Take out the prism retaining plate (54) and the eyepiece prism (58). Care must be taken that the prism is not damaged during this operation.

(f) TO DISASSEMBLE BUBBLE ASSEMBLY.

1. Remove the three ring screws (74). Take out the ring (73) and glass

retainer ring (72) from the bottom of the bubble assembly.

2. Remove the lens retaining ring (53) from the top of the chamber.

3. Remove the bubble chamber plug (70) and drain the fluid.

4. The bubble bottom (71) and the field lens (55) may be removed by heating the assembly enough to soften the shellac which holds them in the bubble chamber.

5. Remove the diaphragm cap assembly (75) by unscrewing it from the bubble chamber. The bubble chamber nut (76) attached to the diaphragm cap must be loosened during this operation.

NOTE: Further disassembly will not be undertaken as the diaphragm is soldered to the bubble chamber. If damaged, replace the entire bubble cell assembly.

(5) TO DISASSEMBLE RIGHT SIDE PLATE ASSEMBLY (Refer to figure 34).

(a) TO DISASSEMBLE INDEX PRISM ASSEMBLY.

1. Remove the two prism adjusting screws (110) and adjusting pivot (109) from the bottom of the index prism carrier (112) with prism adjusting hook (PQ-3152) and lift the index prism assembly from the carrier (112).

2. The index prism (33) is cemented to the index prism holder (113) with shellac. To remove the prism, place the prism and prism holder in alcohol until shellac is dissolved.

NOTE: Removal of the prism will usually involve repainting and resilvering of the prism.

(b) TO DISASSEMBLE RIGHT SIDE COVER ASSEMBLY.

1. Remove the three screws (24) on the edge of the right side plate (34) that hold the right side cover assembly in place. Remove the cover assembly from the right side plate.

2. Remove the four screws (25) and lift off the celluloid card (23) from the right side cover (22).

3. Remove the two screws and lift out worm wheel index.

4. The glass is cemented to the right side cover and may be removed by heating the right side cover (22) to soften shellac.

(c) TO DISASSEMBLE WORM SCALE DRUM ASSEMBLY.

1. Unscrew the scale drum cover (10) from the worm scale drum assembly.

2. Holding the end of the worm gear shaft by means of a pin or a wrench, remove the two nuts (9) using hex nut wrench (PQ-4614). Lift off the worm scale drum assembly, the stop washers (13) and the spacing washers (12).

NOTE: If necessary, the upper stop washer (11) may be removed from the worm scale drum (8) and the lower stop washer (6) from the right side plate by removing the three screws (7 and 14) from each washer. In order to facilitate the location of the lower stop washer correctly upon reassembly, scribe a mark locating the position of the protrusion of the lower stop washer on the plate casting. A similar procedure should be followed in marking the position of the protrusion of the upper stop washer in the scale drum.

3. Remove the two screws (4) and take the scale drum brake assembly (5) off the right side plate.

(d) TO REMOVE BUSHING AND WORM ASSEMBLY.

NOTE: The worm wheel support assembly, bushing and worm assembly, and plunger cannot be disassembled without destroying the accuracy of the instrument. They may be disassembled, if necessary for replacement purposes, but the parts must be recalibrated upon reassembly.

1. Remove the two screws from the lubber line plate and take out the plate.

2. Remove the lubber line locking ring screw (41) and lift off lubber line ring (15).

3. Remove the worm bushing bezel (3) from the right side plate using bushing bezel wrench (PQ-4695).

4. Remove the worm shaft plunger plug (32) and back out the worm shaft plunger screw (31) using plunger adjusting screwdriver (PQ-4616) to permit removal of the worm shaft plunger spring (30) and plunger (29). Carefully turn the bushing and worm assembly (1) until it disengages the worm wheel. Remove the assembly from the right side plate.

NOTE: Since the mesh of the worm and the worm wheel is extremely critical, care must be taken not to damage the gear teeth of the worm. It is advisable to protect the worm gear teeth with a small piece of tape until the worm and bushing assembly (1) is re-assembled in the right side plate. The worm (28) and seating ring (2) must not be removed from the worm bushing as they are lapped and spun in place. If damaged, replace the entire bushing and worm assembly.

5. Remove the steel ball (27) and worm shaft plunger spring (26) from the right side plate.

(g) TO DISASSEMBLE WORM WHEEL SUPPORT ASSEMBLY.

1. Remove two screws (21) from worm wheel dial (17) and lift off worm wheel dial from worm wheel support (114).

2. Remove the nut (117) with the hex nut wrench (PQ-4614) and remove the washer (116). Take out the index prism carrier (112) and the dowel (118) from worm wheel support assembly.

NOTE: Since the index prism carrier is a lapped fit with the worm wheel support, a damaged or worn index prism carrier will necessitate replacement with a new worm wheel support assembly.

3. Remove the two locking screws (20) and two adjusting screws (18) and lift the worm wheel (16) from the worm wheel support (114).

4. Remove the three screws (121) and lift the bearing retainer ring (122) from the right side plate.

5. Remove the three screws (123) that secure the bearing housing to (119) the right side plate. Lift the bearing housing (119), worm wheel support bear-

ing (115) and the worm wheel support (114) as a unit from the right side plate. These parts may be separated by pulling them apart.

NOTE: These three parts are fitted together and if any of these parts is replaced with a new one, it will have to be fitted to the other parts upon reassembly. If the worm wheel support is damaged it will be necessary to replace the entire worm wheel support assembly.

(f) TO REMOVE BATTERY HOLDER.

1. Remove the nut (103) screw washer (101) insulating washer (100) and the screw (99) that secure the battery rear insulator assembly (98) to the rear insulator bracket (97). Take out the battery rear insulator assembly (98). Unsolder the wire from the rear insulator assembly if necessary.

2. Remove the three screws (96) and take off the rear insulator bracket (97).

3. Remove the two screws (84) in battery front insulator assembly (86) and lift off battery front insulator assembly (86).

NOTE: The battery front contact (85) will not be disassembled as it is riveted to the insulator.

4. Remove the three screws (87) and take off front insulator bracket (83).

5. Remove the battery spring support (102) which carries the battery retaining spring (95).

(g) TO REMOVE SPRING CONTACT ASSEMBLY.

1. Unsolder the electrical connection on the spring contact (40) and remove the wire and wire protection tube (36).

2. Remove the two screws (42) and lift off washers (43), bushings (44), spring contact assembly (40) and contact insulation (39).

NOTE: The contact spring is soldered to the contact plate.

3. If necessary, the two spacing pillars (11) may be removed from the right side plate (34).

(6) TO DISASSEMBLE LEFT SIDE PLATE ASSEMBLY (Refer to figure 23).

NOTE: The cover assembly was previously removed when the left side plate assembly was separated from the right side plate.

(a) Remove the two horizon adjusting screws (28) with prism adjusting hook (PQ-3152) and remove the horizon prism holder assembly from the horizon prism carrier assembly (27).

NOTE: The horizon prism (19) is cemented to the holder by means of shellac and, if necessary, may be removed by dissolving the shellac in alcohol. This will usually involve repainting and resilvering of the prism.

(b) Remove the nut (27) using hex nut wrench (PQ-4614) and take out lock-washer (23), washer (24) and the horizon prism carrier assembly (27) with the two dowel pins (17). The horizon prism carrier assembly cannot be disassembled further as the carrier stud is staked on the prism carrier.

(c) Remove the two mounting screws (21) and take out the adjusting plate (8) from the left side plate (14). The two adjusting screws (9) may be removed from the adjusting plate (8) if necessary.

(d) Remove the two screws (15) from bottom of left side plate and lift off shade holder spring (16).

(e) Remove the screw (10) that holds the shade glass assembly (18) to the left side plate (14) and take out the shim (12) shade glass assembly (18) and the spacer washer (11).

NOTE: The shade glasses may be removed if necessary for replacement, by heating the shade glass assembly enough to soften the cement. Early models of the type 3003-A did not contain a shim between the screw and the shade glass assembly.

(f) Remove the two screws (3) and take the two washers and insulating wash-

ers (2) contact spring assembly (5), contact spring insulator (6), stationary contact spring assembly (4), and the insulating bushings (1) out of the left side plate (14). Remove the switch button (20).

NOTE: Do not disassemble the contact spring assemblies as the contacts are riveted to the springs.

3. INSPECTION AND REPAIR.

a. GENERAL.

(1) After disassembly, it is essential to keep all parts absolutely clean and free from dust so that the complete instrument will function properly when reassembled.

(2) Inspect all parts for wear or damage; replace if necessary. Make sure that all parts are clean.

b. OPTICAL SYSTEM.

CAUTION: Do not use oil on any part of the optical system.

(1) Inspect lenses and glasses for cracks and replace if defective.

(2) Inspect the surfaces of the prism for defective silver or paint. Resilver or repaint the surfaces if necessary.

(3) Check the prisms for cracks or any other defects and replace, if necessary.

(4) Inspect luminous painted surfaces and repaint if necessary.

(5) Inspect the shade glass assembly. If any of the shade glasses are cracked, remove the defective glass and replace with a new shade glass.

(6) Make sure all prisms, lenses and glasses are clean before reassembling them into the instrument.

c. WORM WHEEL SUPPORT ASSEMBLY.

(1) Inspect the worm and bushing assembly and the worm wheel for wear or damage. If either worm and bushing assembly or the worm wheel is chipped or defective, replace with a new part. These parts must be kept free of dust and dirt before reassembling them in the instrument.

(2) Check the ball bearing for dirt, dust, rust, scratches and pits. Replace if necessary.

CAUTION: Do not use oil on any part of the worm wheel support assembly.

d. WIRING

(1) Inspect wiring for any defects or poor connections.

(2) Check for proper illumination from 2 volt lamp on type A-5 (1067).

(3) Polish contact points with a fine grade of crocus cloth.

e. TYPE BJ-1 AVERAGING DEVICE. - The BJ-1 averaging device does not require any regular periodic inspection as there is very little friction in its moving parts. If persistent irregularities in readings are noted, despite readjustments, disassemble and inspect parts for damage and wear. Inspect the vernier shoe assembly for damage to the brake shoe spring and brake shoe. Check the brake surface of the shoe for wear or pitted surface. Any indications of damage or wear which affects the accuracy of the device will necessitate sending the entire averaging device back to the manufacturer for replacement of parts as a new vernier shoe assembly must be lapped to insure perfect fit with the vernier. Inspect carefully the following parts particularly the moving surfaces that have a close fit with other parts; dial, vernier, vernier bearing, segment, and cover. If surfaces are pitted and replacement is necessary, the entire device should be sent to the manufacturer and the new parts lapped to fit. Inspect vernier stop lever spring and lever. If damaged or worn, replace with a new vernier stop lever assembly. Inspect vernier spring for fit and wear. This spring can be bent to give more friction but if worn, replace with a new one. Check the fit of the adjusting screw in the adjusting screw housing, replace if necessary.

f. TYPE BJ-4 AVERAGING DEVICE. - The BJ-4 averaging device does not require any regular periodic inspection as there is very little friction in its parts. If irregularities in readings cannot be remedied by readjustment, inspect parts for damage or wear. Inspect the pencil lead, if the point is dull, remove the

lead and sharpen to a fine, sharp point. Check the fit of the sleeve and replace if a loose fit. Check the fit of the stud joining the trigger and the base plate and replace it if necessary. Inspect the trigger spring, any indication of wear will necessitate replacement of spring. Inspect the ratchet spring and ratchet stop spring, if they cannot be adjusted by bending, replace them. Check the fit of the adjusting screw, replace if necessary.

4. REASSEMBLY.

a. TYPE A-5 (1067).

(1) TO REASSEMBLE LEFT SIDE PLATE ASSEMBLY.

(a) Place the switch button in the hole provided in the left side plate and fasten two insulating bushings, contact spring assembly, contact spring insulator, stationary contact spring assembly, two insulating washers and two screw washers onto the left side plate with two screws.

(b) Fasten the spacer washer and shade glass assembly on the left side plate with the shade holder screw.

(c) Fasten the shade holder spring into place on the bottom of the left side plate with the two screws.

(d) Set the adjusting plate in place and fasten with the two mounting screws.

(e) Key in and cement the horizon prism on the horizon prism holder with Varnish, Shellac, Spec. TT-V-91A.

NOTE: No strain must be placed on the prism when cementing it in place.

(f) Fasten the horizon prism holder assembly on the horizon prism carrier assembly with the two horizon adjusting screws.

(g) Slide the horizon prism assembly into the left side plate, place the two dowel pins in the holes provided, and fasten the horizon prism assembly in place with the nut, lockwasher and washer.

(h) Place the two adjusting screws into the adjusting plate.

(2) TO REASSEMBLE RIGHT SIDE PLATE ASSEMBLY.

(a) TO REASSEMBLE SPRING CONTACT ASSEMBLY.

1. Fasten the contact insulation, spring contact assembly, the two bushings and washers on the right side plate with two screws.

2. Fasten the two spacing pillars to the right side plate. Slide on the wire and the wire protecting tube on the top pillar and solder the end of the wire to the spring contact assembly.

(b) TO REASSEMBLE BATTERY HOLDER.

1. Fasten the front insulator bracket on the right side plate with the three screws.

2. Fasten the battery front insulator assembly to the bracket with the two screws.

3. Fasten the rear insulator bracket into place with the three screws.

4. Resolder the wire from the front insulator assembly to the rear insulator assembly (refer to wiring diagram figure 25) and fasten the rear insulator assembly, insulating washer, and screw washer onto the bracket with the screw and nut.

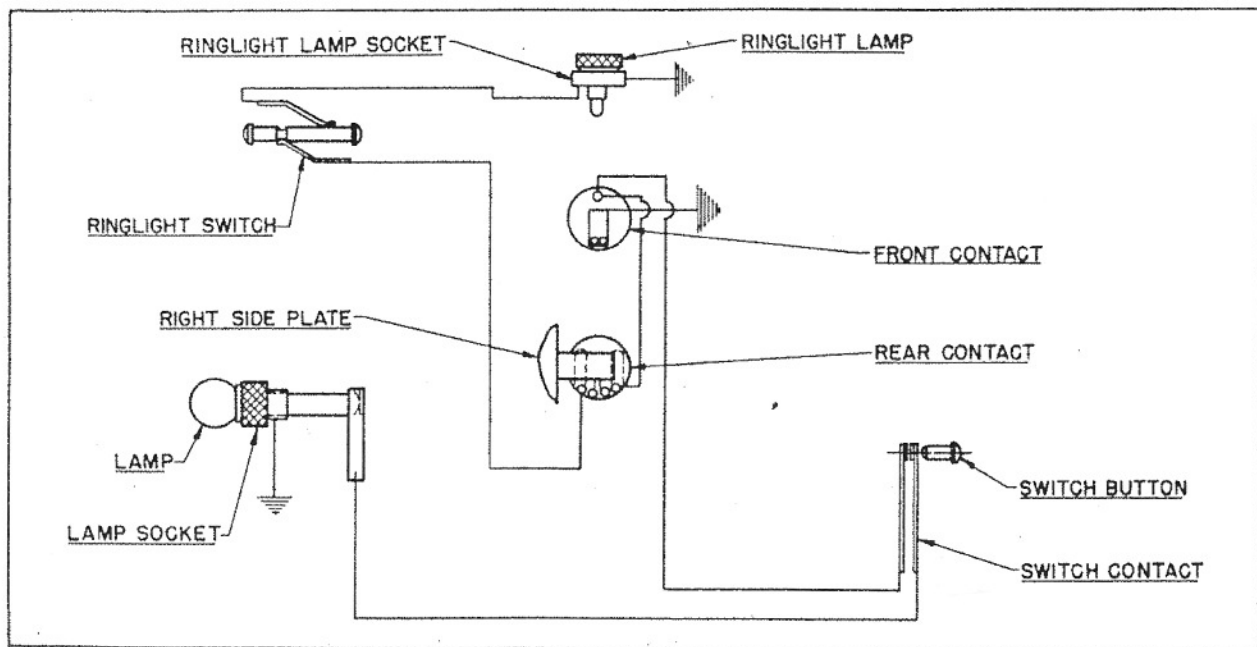

Figure 25 - Wiring Diagram - Aircraft Sextant - Type A-5 (1067)

5. Fasten the battery spring support, which carries the battery retaining spring, into place on the right side plate.

(c) TO REASSEMBLE INDEX PRISM ASSEMBLY.

1. Key in and cement the index prism on the index prism holder with Varnish, Shellac, Spec. TT-V-91.

2. Place the index prism assembly on the index prism carrier and secure in place with the two adjusting screws and adjusting pivot.

NOTE: Adjustment of the index prism assembly will be made during final adjustment of the instrument.

(3) TO REASSEMBLE TELESCOPE ASSEMBLY.

(a) TO REASSEMBLE BUBBLE ASSEMBLY.

1. Solder the diaphragm to the expansion chamber screw and then, to this, solder the screw washer to form the diaphragm assembly. Use Non-Corrosive Soldering Paste, Spec. 2-89, and, after soldering, clean the surfaces carefully with Benzine, Spec. 4-1016, or some other solvent and then wash with very hot water. The surface of the diaphragm, is against the liquid in the chamber and must be cleaned very carefully.

2. Tin with soft solder the shoulder and the side of the ring against which the diaphragm is attached. Clean all flux off well. Solder the diaphragm assembly in position, using Non-Corrosive Soldering Paste, Spec. 2-89, only on the outside of the diaphragm.

3. Place the bubble cell assembly on a hot plate and hold at such a temperature that the shellac will remain in a fluid state on the surface of the cell.

4. Place a very thin layer of Varnish, Shellac, Spec. TT-V-91 on the shoulder upon which the bubble bottom glass rests. Set the bubble bottom glass on the shellac. Put another layer of shellac at the joint between the glass and the metal. It is important to avoid getting shellac inside the cell.

5. While the shellac is still fluid, screw the retaining ring in place.

It should be screwed down sufficiently to hold the glass in place without straining the glass.

6. The field lens should then be cemented to bubble chamber top in the same manner in which the bubble bottom glass was cemented. The lens must be placed in such a manner that the cross lines on the lens are in the proper position. Be sure that the lens sets flat in the bubble chamber as improper seating will introduce an error. Place the lens retaining ring in position above the lens.

7. Insert one end of a capillary tube about 6 inches long into the hole reamed for the taper pin. The end of the tube should taper to fit snugly into the hole. The other end should be dipped under the surface of a quantity of Xylene, Spec. AN-R-X-876.

8. The whole setup, described in the preceding paragraph, should be placed in an air-tight chamber and subjected to a partial vacuum for about 20 minutes. A pressure of 25 or less millimeters of mercury is satisfactory. By this process the chambers are evacuated and air is also removed from the liquid. As an added precaution it is advisable to subject the liquid previous to filling the chamber, to the above-mentioned partial vacuum for at least 30 minutes.

9. Allow air to enter the air-tight chamber slowly. This forces liquid into the bubble cell chamber.

10. Remove the capillary tube and fill the chamber completely with liquid. If a small bubble of air remains in the chamber, the cell should be tilted so that it will pass out through the taper pin opening and the cell completely filled with liquid.

11. Place the taper pin tightly into the reamed opening. It should not be tapped into place but pushed in tightly while being rotated.

12. Place the light ring and the aluminum reflector into the bubble chamber. Care must be taken that the V-shaped notch in the light ring is placed directly in front of the insert, which is cemented in the semi-circular notch in the side of the chamber. The aluminum re-

flector is placed in the V-shaped notch in the light ring. Cement the light stop on the top of the light ring over the V-shaped notch with Lacquer, Cellulose Nitrate, Spec. AN-TT-L-51. The white surface of the light stop must face toward the light ring. Replace the luminous paint ring so that split ends of the ring are at the insert. Replace the spacing ring and secure it in position with the three ring screws.

(b) TO REASSEMBLE EYEPIECE PRISM ASSEMBLY.

1. Place the eyepiece lens into the lens housing and secure in place with the eyepiece bezel. Do not tighten the bezel excessively as this may crack the lens. Replace the adjusting ring onto the lens housing.

2. Set the lens housing into the eyepiece prism carrier and fasten in place with the three ring retaining screws and the one housing retaining screw.

3. Set the eyepiece buffer assembly in place on the lens housing. Fasten in place with the mounting spring and eyepiece nut.

4. Place the eyepiece prism with its side packings into the prism carrier. Place the eyepiece prism packing in position and slide the eyepiece prism housing onto the prism carrier. Align the holes in the housing and the carrier and secure them together with the four prism housing screws.

(c) TO REASSEMBLE OBJECTIVE LENS ASSEMBLY.

1. Place the objective lens and spacing ring into the objective tube, being careful to place the front surface of the lens in its correct position in the tube. The front surface of the lens was marked at disassembly.

2. Place the lens retaining ring and diaphragm into the objective tube and fasten in place with the lens lock ring. Make sure the hole in the lens ring is aligned with the hole in the objective tube assembly.

(d) TO REASSEMBLE ASTIGMATIZER LENS AND GLASS IN ASTIGMATIZER PLATE.

1. Set the astigmatizer glass into the opening in the astigmatizer plate and replace the astigmatizer lens nut. Fasten in place with the set screw.

2. Set the astigmatizer lens into the mounting ring and secure in place with the spacing ring and astigmatizer lens ring.

3. Replace the mounting ring with the lens into the astigmatizer plate and temporarily secure in place with the set screw.

NOTE: Do not tighten the set screw as final adjustment of the lens will be made during calibration of the telescope assembly.

(e) TO REASSEMBLE TELESCOPE CASTING ASSEMBLY.

1. Replace the ringlight shutter and washer and fasten in place with the shutter pivot.

2. Fasten the ringlight socket in place with the set screw. Replace ringlight bulb.

3. Replace ringlight shutter stop assembly by screwing it into place.

4. Solder the electrical lead connection at the top of the switch assembly. Place the ringlight switch assembly on the telescope casting and fasten with two screws. Solder the lead in the telescope casting to the switch assembly.

5. Place the roof prism and roof prism support into the telescope body and tighten in place with the prism support screw.

6. Slide the astigmatizer plate assembly onto the bushing in the telescope body.

7. If the astigmatizer control knob has been removed, screw the knob into the astigmatizer plate and place the knob adjusting screw in the knob. Be sure the knob adjusting screw in the knob is parallel to the length of the slot.

8. Screw the telescope tube into the astigmatizer cover.

9. Hook the astigmatizer spring to the pin on the astigmatizer plate and the pin on the astigmatizer cover and fasten the astigmatizer cover assembly to the telescope casting with the three cover screws.

10. Slide the objective lens assembly into the telescope tube and hold in place with the set screw.

(f) TO REASSEMBLE BUBBLE ASSEMBLY TO EYEPIECE PRISM ASSEMBLY. - Place the spring washer and retainers in place about the raised step of the bubble chamber. Rotate the retainers to an intermediate 45° position with respect to the telescope body. Place the eyepiece prism assembly in position over the retainers and fasten the eyepiece prism assembly to the retainers with four screws. The eyepiece prism assembly must be free to rotate.

(g) TO REASSEMBLE BUBBLE AND EYEPIECE PRISM ASSEMBLIES TO TELESCOPE CASTING ASSEMBLY. - Place the bubble and eyepiece prism assemblies in position on the telescope casting assembly. Rotate the eyepiece prism assembly to a 45° angle with respect to the telescope body and replace the four screws in the top of the bubble chamber. Place two screws in the holes on the left side of the bubble chamber and tighten.

(h) TO CALIBRATE TELESCOPE ASSEMBLY.

1. Set the telescope assembly on a horizontal collimator adjusted to give parallel rays of light on the same plane as that occupied by the bubble, or sight on a distinct distant object 800 or more feet distant.

2. Form a bubble in the bubble chamber and focus the eyepiece sharply on the bubble. Center the bubble in the middle of the field.

3. Adjust the roof prism in the telescope body so that the image of a vertical object is parallel to the vertical line etched on the field lens. To facilitate adjustment of the prism, place a No. 4-48 screw, approximately $3/4$ " long, into the hole in the prism support.

Loosen the prism support screw and by means of the screw inserted in the prism support, shift the position of the roof prism so that the image is aligned. Tighten the prism support screw securing the roof prism in position and remove the No. 4-48 screw.

4. With the astigmatizer lens in the optical field, note the thickness of the horizontal line of the collimator target. If the astigmatized image of the horizontal line appears thicker than the unastigmatized image, the astigmatizer lens must be adjusted as follows: Loosen the set screw that holds the objective lens assembly in position and remove the objective lens assembly. Insert the wrench (PQ-6004) into the hole in the telescope tube and rotate the mounting ring a slight amount. Replace the objective lens assembly and note the astigmatization of the image. Repeat this procedure until the astigmatized image is as thin as possible. After the astigmatizer lens is properly adjusted, remove the three cover screws and take the astigmatizer cover assembly with the astigmatizer plate assembly out of the telescope casting. Tighten the set screw, locking the mounting ring in the astigmatizer plate assembly. Replace the assemblies into the telescope casting and secure the astigmatizer cover in place with the three screws. Fine adjustment of the astigmatizer lens is made by moving the set screw on the control knob in or out and then securing it in position with a small amount of shellac.

5. Adjust the objective lens as follows: Sight on the collimated image or upon a distinct distant object about 800 or more feet distant. Move the eye up and down a small distance and if there is no parallax, i.e., no relative motion between the image and the bubble, the objective lens assembly is properly adjusted. The image and the bubble should both appear sharp. If parallax is present, move the objective lens assembly in or out, enough to eliminate it. Place the set screw in the hole at the top of the telescope tube and lock the objective lens assembly in position. It may be necessary to file the clearance hole in the telescope tube for the set screw before replacing it after adjustment.

(4) TO REASSEMBLE RIGHT AND LEFT SIDE PLATE ASSEMBLIES.

(a) Guide the spacing pillars on the right side plate into the holes in the left side plate and fasten with the two nuts and one screw.

(b) Thread the wire from the spring contact assembly on the right side plate through the hole in the left side plate and solder it to the movable contact spring assembly. Guide the wire from the battery front insulator assembly through the hole in the left side plate and solder it to the stationary contact spring assembly. Refer to wiring diagram figure 25.

(c) Set the left side cover assembly in place on the left side plate and fasten with the three screws.

(5) TO REASSEMBLE TELESCOPE ASSEMBLY TO RIGHT AND LEFT SIDE PLATES.

(a) Set the telescope assembly carefully between the right and left side plates and secure it in place with the four screws through the right side plate and one screw through the left side plate.

(b) Solder the wire which passes through the telescope casting to the contact on the battery rear insulator assembly. Refer to wiring diagram figure 25.

(6) TO REASSEMBLE RIGHT SIDE COVER ASSEMBLY.

(a) Place the scale window into the right side cover and cement it in place with shellac.

(b) Mount the worm wheel index in the right side cover so that its index mark is visible through the scale window and secure it with the two screws.

(c) Replace the celluloid card so that its cut-out is at the scale window and fasten it in position with the four screws.

(d) Place the right side cover assembly on the right side plate and secure in place with the three screws.

(7) TO REASSEMBLE WORM SCALE DRUM ASSEMBLY.

(a) Fasten the scale drum brake assembly on the right side plate with the two screws.

(b) Fasten the lower stop washer to the right side plate with three screws. Be sure the protrusion of the washer is in the correct position as indicated by the mark scribed during disassembly.

(c) Place the twelve stop washers on the shaft of the bushing and worm assembly so that the protrusions of the stop washers face downward. To provide .003 to .005 clearance between the lubber line ring and the scale drum assembly, it may be necessary to insert spacing washers between the stop washers so that the clearance is taken up, yet the washers are free to rotate. The number of spacing washers may vary from one to five and in no case should more than one spacing washer be used between any two stop washers.

(d) It is important that the upper stop washer be properly located in relation to the scale drum as this determines the positions of the worm wheel. The overtravel of the worm wheel should be limited to approximately 5° beyond the 0° and 90° extreme positions. This is accomplished as follows: Rotate the worm wheel by means of the bushing and worm assembly so that the scale visible through the scale window reads zero. Rotate the stop washers in a counterclockwise direction, without altering the position of the bushing and worm assembly, so that the protrusions of the stop washers are in contact with each other. Hold the scale drum so that the 5° graduation is aligned with the reference mark on the lubber line plate and note the position that the upper stop washer will have to occupy in the scale drum when the protrusion of the upper stop washer is in counterclockwise contact with the other stop washers. Secure the upper stop washer in the scale drum with the three screws. Place the scale drum on the bushing and worm assembly and rotate the drum counterclockwise until the upper stop washer makes contact with the other stop washers. The 5° graduation should be approximately in line with the reference mark. The drum should then be rotated clockwise until the 0° graduation on the scale drum is aligned with the reference mark. Lock the scale drum in zero position with the two nuts, and screw on the scale drum cover. The bushing and worm assembly must not be moved during this operation as this will result in an incorrect setting of the stop positions.

NOTE: The above adjustment of the stop positions will be facilitated if the location of the protrusion of the upper and lower stop washers are marked on the scale drum and right side plate respectively at disassembly.

(8) FINAL ADJUSTMENTS.

(a) For these adjustments an accurately set horizontal collimator or natural horizon should be used. If a collimator is used, it should preferably have a horizontal collimation line. If no collimator is available, a light or line some 800 or more feet distant, exactly at the same height as the sextant may be used. The light or line should be located by means of a transit or surveyor's level. For convenience, the sextant must be clamped to some rigid structure during the checking and readjustment operations. The bubble, about 3/32" in diameter, must be formed and be approximately in the middle of the field. If the natural horizon is used, correction for the "Dip of the Horizon" must be applied.

(b) With both scales set at zero, the horizon shutter knob in its extreme position in the direction opposite to the arrow, and the proper size bubble in the center of the field, note the position of the image in respect to the bubble. Adjust the index prism until the image is brought into collimation with the bubble. This adjustment is made by tightening one and loosening the other of the two prism adjusting screws on the underside of the prism carrier using the prism adjusting hook (PQ-3152). Upon completion of this adjustment, the screws must be tight but not tight enough to put excessive strain on the prism.

(c) With the horizon shutter knob in its extreme position in the direction indicated by the arrow, note the position of the image with respect to the bubble. Adjust the horizon prism in the same manner as performed for the index prism, outlined in the previous step.

(d) It may also be necessary to adjust the prisms for horizontal coincidence, that is, the images of some vertical object do not coincide exactly. Set up the sextant with the bubble at the center of the field and sight on a

vertical line which passes through the center of the field. If the lateral position of the line shifts when the micrometer drum is turned, the prism must be adjusted by means of the prism adjusting pivot underneath the index prism carrier. The image through the horizon prism must then be adjusted to coincide with the image through the index prism. This is accomplished by removing the left side cover assembly and by loosening one and tightening the other of the two mounting screws that secure the adjusting plate to the left side plate.

(e) Set the instrument on the horizontal collimator so that the bubble will be in the center of the field. Focus the eyepiece sharply on the bubble. Sight through the index prism and adjust the size of the bubble so that it is tangent to the two horizontal target lines of the collimator. Tilt the instrument so that the bubble will travel 4° above and below the center of the field and note the motion of the bubble and the target line relative to each other. If one moves faster than the other, i.e., the bubble is no longer tangent to the two horizontal target lines; rotate the index prism by means of the scale drum so that the target lines are tangent. Note the reading of the scale drum. If the error exceeds two minutes and is uniform at the 4° points above and below the center of the field, refocus the objective lens assembly in accordance with the procedure outlined in paragraph 4. a. (3) (h) Calibration of Telescope Assembly, this section. If the error exceeds two minutes and is not uniform at the 4° points above and below the center of the field, the field lens is not properly seated in the bubble chamber or is distorted.

b. TYPE A-7 (A-5A) AVERAGING DEVICE (BJ-1).

(1) TO REASSEMBLE SEGMENT ASSEMBLY.

(a) Attach the segment stop pins to the segment by screwing them in place.

(b) Place the brake spring on the segment and secure in place with two brake spring screws.

(2) TO REASSEMBLE DIAL AND VERNIER.

(a) Mount the vernier on the vernier bearing and secure with three ver-

nier bearing screws. Before placing the vernier spring on the vernier bearing, it should be bent to suit. Insert the lock lever stud spacer and the segment assembly in the back side of the cover and place back side down on a bench. With a fine stiff wire, fashioned to form a hook at one end and inserted through the slot cut in the cover, hook the vernier shoe assembly and pull back carefully. Replace the vernier and vernier bearing into the cover, release the vernier shoe assembly, and remove the wire.

(b) Secure both the segment assembly and the vernier to the cover with the vernier retaining stud and stud locking nut.

(c) The lock lever should be assembled into the device at this stage as it will aid in moving the vernier and segment assembly when further reassembling the device. Place the lock lever into the slot cut in the cover. To secure to the segment, pass lock lever stud through the hole provided for it in the segment and through the lock lever stud spacer. Secure to lock lever and tighten.

(d) Mount the dial with the holes and cut coinciding with those in the cover. Secure to cover with three dial screws.

(e) To assemble the adjusting screw housing simply screw the housing into the hole provided for it in the cover.

(f) Turn the averaging device with the back facing upward. By means of the lock lever, turn the vernier until the zero stop slot is in a position which will permit the assembly of the vernier stop lever assembly to the cover. Insert vernier stop lever stud into the vernier stop lever assembly and then slip vernier stop lever washer onto the stud, so that the washer is between the vernier stop lever and the cover thus preventing friction. Place into the cover and tighten stud. The vernier stop lever spring should be bent to suit at assembly.

(g) Place the adjusting screw into the adjusting screw housing and tighten about halfway. Reset the vernier by turning it, by means of the vernier knob, in a clockwise direction until stopped.

The both scales should read zero but if not, the vernier dial zero stop must be adjusted. In order to adjust it, turn the adjusting screw. To move the stop position of the inner vernier in a clockwise direction, move the adjusting screw out.

(h) Adjustment of the brake spring is necessary to insure smooth movement of the vernier and the segment. To adjust, tighten or loosen, as the case may be, the spring by means of the brake adjusting screw to give sufficient friction between the cover and the segment in order to prevent the slipping of the segment until sufficient friction is built up between the vernier brake shoe and the vernier drum and thereby, cause the vernier to turn.

(3) TO REASSEMBLE SEGMENT STOP SCREW SUPPORT.

(a) Screw the segment stop screw into the stop screw support.

(b) Slip the adjusting knob onto the stop screw and secure the knob with the adjusting knob stud.

(c) Mount the support on the cover, it being located by means of two pins and held to the cover by two support screws.

(d) Put in the locking screw and tighten temporarily. This screw prevents the stop screw from turning after adjustment.

(4) TO REASSEMBLE BJ-1 AVERAGING DEVICE ONTO SEXTANT.

(a) Place the sextant on a bench with the right side facing upward. With the four averaging device adjusting screws loosened, carefully place the device onto the sextant. The four screws on the periphery of the cover should be tightened sufficiently in order to hold it fixed. These four screws center the averaging device. A small shift in the position of these screws will throw the device off center and introduce a considerable error in the readings. Therefore, it is of great importance that the device is centered when assembling it on the sextant.

(h) The procedure for centering the averaging device is one of trial and error. Three readings with the sextant are taken at different angles, for example; 9° , 45° and 90° . The reading on the vernier, after operating the averaging device eight times for some one setting of the drum, should correspond to that of the sextant. Should they read a constant deviation for all three different angle readings, the device is centered, but the zero stop is out of adjustment. If only one or two of the three readings give a plus or minus deviation, the device is off center and must be adjusted by loosening either pair of the adjusting screws and shifting the device either horizontally or vertically, as case may require, to eliminate the error. This process is repeated until the error has been completely eliminated. Now the device is centered and the four set screws can be tightened permanently.

(c) To adjust the zero stop, the locking screw is loosened enough so that the adjusting knob may be turned. Pushing the edge of this knob up increases the travel of the shoe. The following procedure is suggested for setting this stop. Turn the knob on the sextant in a counterclockwise direction until it is against the stop, the zero reading of the instrument. The zero lines on the knob and the lubber line should line up. The zero stop should be roughly adjusted by loosening the locking screw and rotating the adjusting knob by a slight pressure of the finger until resistance to motion is felt. This should give an adjustment to within five minutes (5'). Closer adjustment is accomplished as follows: Turn the knob of the sextant through one complete revolution, and line up the index marks at 10° . The lock lever should then be operated eight times and the reading should be 10° . In case the reading is not 10° , loosen slightly the locking screw and turn the adjusting knob a small amount. Reset the vernier to zero and again operate the lock lever eight times. Repeat this adjustment until the error is sufficiently small. Tighten the locking screw.

g. TYPE A-7 (3003-A AND 3003-B).

(1) TO REASSEMBLE LEFT SIDE PLATE ASSEMBLY (Refer to figure 23).

(a) Place the switch button (20) into the hole provided in the left side plate (14) and fasten two insulating bushings (1), contact spring assembly (5), contact spring insulator (6), stationary contact spring assembly (4), two insulating washers (2), and two screw washers onto the left side plate (14) with two screws (3).

(b) Fasten the spacer washer (11), shade glass assembly (18) and shim (12) on the left side plate (14) with the shade holder screw (10). There must be no play between the shade glass assembly (18) and the shade holder screw (10), yet the assembly must be free to rotate. Adjust the play by placing a shim, having the proper thickness, into the counter-bore of shade glass holder. The shade holder screw will have to be temporarily removed in order to change the shim. Select a shim from the various sized shims as indicated in the following table.

Shim No.	Thickness
PB-24662-1	.010"
PB-24662-2	.012"
PB-24662-3	.014"

NOTE: Early models of 3003-A are not provided with a shim between the shade glass holder and the shade holder screw. Only on those models which contained a shim upon disassembly will a shim be reassembled.

(c) Fasten the shade holder spring (16) into place on the bottom of the left side plate (14) with the two screws (15).

(d) Set the adjusting plate (8) in place and fasten with the two mounting screws (21).

(e) Key in and cement the horizon prism (19) on the horizon prism holder

with Varnish, Shellac, Spec. TT-V-91. Cement the felt horizon prism spacer on the horizon prism.

NOTE: No strain must be placed on the prism when cementing it on the holder.

(f) Fasten the horizon prism holder assembly on the horizon prism carrier assembly (27) with two horizon adjusting screws (28) so that the holder assembly is parallel to the carrier assembly.

NOTE: Final adjustment of the horizon prism will be made during final adjustment of the instrument.

(g) Slide the horizon prism assembly into the left side plate, place the two dowel pins (17) in the holes provided, and fasten the horizon prism assembly in place with the lockwasher (23), washer (24), and nut (22). Use hex nut wrench (PQ-4614) to tighten the nut.

NOTE: If either the horizon prism carrier or the adjusting plate is replaced with a new part, it will be necessary to locate new holes for the dowel pins. Refer to paragraph g. (7) (d), this section.

(h) Place the adjusting screws (9) into the adjusting plate (8).

(2) TO REASSEMBLE RIGHT SIDE PLATE ASSEMBLY. (Refer to figure 24).

(a) TO REASSEMBLE SPRING CONTACT ASSEMBLY.

1. Fasten the contact insulation (39), spring contact assembly (40), the two bushings (44) and washers (43) on the right side plate with the two screws (42).

2. Fasten the two spacing pillars (111) to the right side plate (34). Slide on the wire and wire protecting tube (36) on the top pillar and solder the end of the wire to the spring contact assembly (40).

(b) TO REASSEMBLE BATTERY HOLDER.

1. Fasten the front insulator bracket (83) into the right side plate (34) with the three screws (87).

2. Secure the battery front insulator assembly (86) to the bracket (83) with the two screws (84).

3. Fasten the rear insulator bracket (97) into place with the three screws (96).

4. Resolder the wire to the rear insulator assembly (98) if the wire was removed and fasten the rear insulator assembly (98) insulating washer (100) and screw washer (101) onto the bracket (97) with the screw (99) and nut (103). Refer to wiring diagram figure 26.

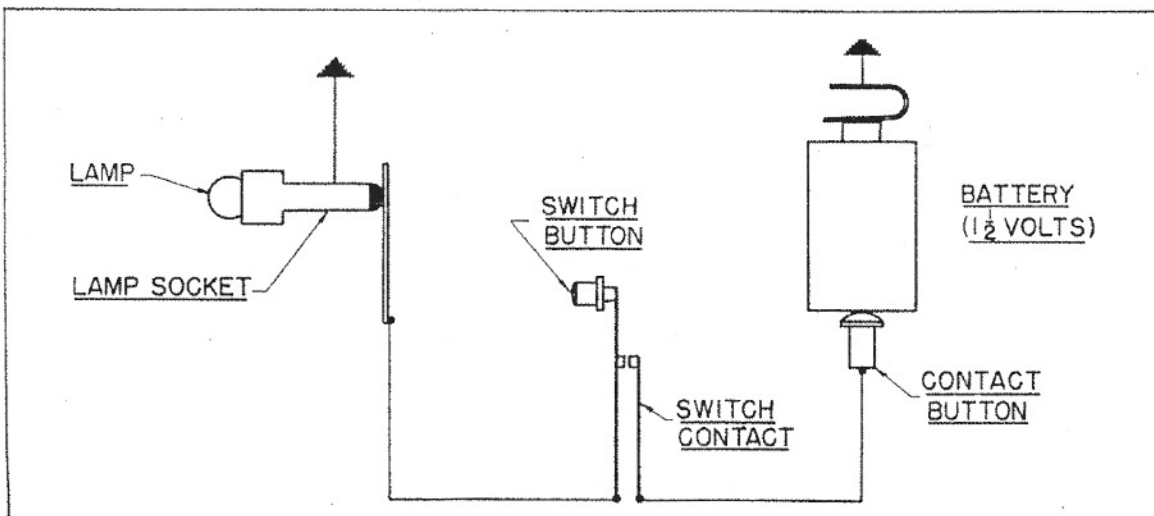

Figure 26 - Wiring Diagram - Aircraft Sextant - Type A-7 (3003-A, 3003-B)

5. Fasten the battery spring support (102) which carries the battery retaining spring (95) and the right side plate (34).

(c) TO REASSEMBLE WORM WHEEL SUPPORT ASSEMBLY.

1. Place the worm wheel dial (17) onto the worm wheel support (114) and secure with the two screws (21) and dowel pin (19).

NOTE: If the worm wheel dial is replaced with a new dial, it will have

to be located properly on the worm wheel support. Locate the new dial as shown in figure 27. If the transfer of the .059" diameter hole necessitates enlarging the hole already in the worm wheel support locate another .059" diameter hole on the worm wheel dial and drill it through the worm wheel support. Ream the hole if necessary for a press fit with the dowel pin. If the worm wheel (16) is attached to the worm wheel support (114) care must be taken not to damage the worm wheel teeth when performing this operation.

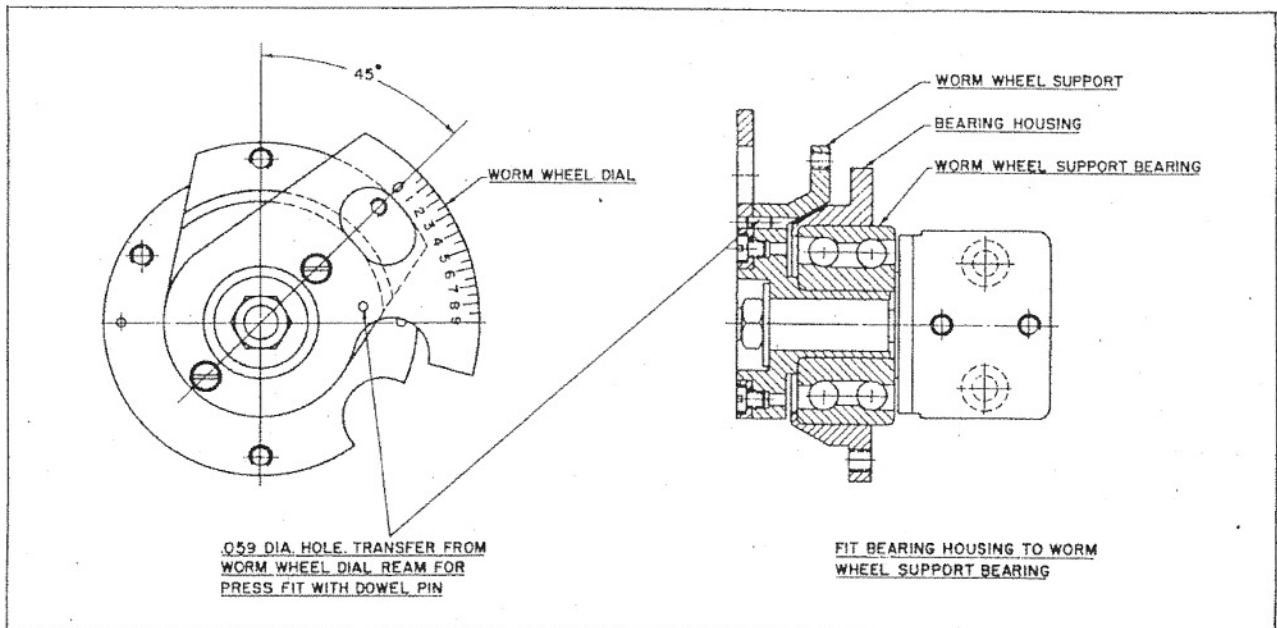

Figure 27 - Sectional View - Worm Wheel Support Assembly Aircraft Sextant - Type A-7 (3003-A, 3003-B)

2. Set the worm wheel support bearing (115) bearing housing (119) and worm wheel support (114) with the dial (17) into the right side plate (34) and fasten with the three screws (123). Also place the dowel pins (120) into the holes provided in the bearing housing (119).

NOTE: If the worm wheel was removed from the worm wheel support, during disassembly, set the worm wheel in place on the worm wheel support and fasten with the two lockscrews (20) and two adjusting screws (18). The calibration of the worm wheel will be made upon reassembly of the entire instrument. Also, if the bearing

housing is replaced with a new part, it will have to be fitted to the worm wheel support bearing. It may be necessary to polish the inner surface of the bearing housing so that it has a light push fit with the outer diameter of the worm wheel support bearing. Place the bearing housing in a lathe and polish the inner surface with fine crocus cloth. (Refer to figure 27) In addition to fitting the bearing housing to the worm wheel support bearing, the bearing housing must be doweled to the right side plate. If the two dowel holes in the bearing housing do not match with the holes in the right

side plate, rotate the bearing housing 120° and transfer the two holes .0595 diameter from the bearing housing onto the right side plate. Ream the holes for a press fit with the dowel pins. If a new right side plate is used, the two .0595 diameter holes will have to be transferred from bearing housing to the new right side plate. (Refer to figure 24).

3. Fasten the bearing retainer ring (122) on the right side plate (34) with the three screws (121).

4. Slide the index prism carrier (112) into the worm wheel support (114). Replace the washer (116) and tighten the nut (117) onto the end of the prism carrier (112) using hex nut wrench (PQ-4614).

NOTE: If the index prism carrier is damaged or worn, replace the entire worm wheel support assembly. The index prism carrier will be doweled in its proper position during calibration of the worm wheel.

(d) TO REASSEMBLE BUSHING AND WORM ASSEMBLY.

1. Place the worm spring (26) and the steel ball (27) into position in the right side plate (34).

2. Slide the bushing and worm assembly (1) into the right side plate. Fasten the worm bushing bezel (3) around the bushing and worm assembly (1) with bushing bezel wrench (PQ-4695).

3. Set the worm shaft plunger (21) and worm shaft spring (30) into the right side plate. Screw the worm shaft plunger screw (31) into the right side plate holding the worm shaft plunger and spring in place.

4. Replace the lubber line ring (15) and secure it in place with lubber line lock ring screw (41). Mount the lubber line plate on the lubber line ring and secure in place with the two screws.

(e) TO REASSEMBLE INDEX PRISM ASSEMBLY.

1. Key in and cement the index prism (33) on the index prism holder (113) with Varnish, Shellac, Spec. TT-V-91.

2. Place the index prism assembly on the index prism carrier (112) and secure in place with the two adjusting screws (110) using prism adjusting hook (PQ-3152) so that the index prism holder is parallel to the prism carrier.

NOTE: Mount the assembly on the carrier so that the adjusting pivot (109) in the carrier is seated in the elongated groove in the bottom of index prism holder. Adjustment of the index prism will be made during the final adjustment of the instrument.

(3) TO REASSEMBLE TELESCOPE ASSEMBLY (Refer to figure 24).

(a) TO REASSEMBLE BUBBLE ASSEMBLY.

1. Place the bubble cell assembly on a hot plate and hold at such a temperature that the shellac will remain in a fluid state on the surface of the cell.

2. Place a very thin layer of Varnish, Shellac, Spec. TT-V-91, on the shoulder upon which the bubble bottom glass (71) rests. Set the bubble bottom glass on the shellac. Put another layer of shellac at the joint between the glass and the metal. It is important to avoid getting shellac inside the cell. While the shellac is still fluid, screw the glass retaining ring (72) in place. It should be fastened sufficiently to hold the glass in place without straining the glass.

3. The field lens (55) should then be cemented to the bubble chamber top in the same manner that the bubble glass was cemented. The lens must be placed in such a position that the cross lines on the lens are in the proper position. Be sure that the lens sits flat in the bubble chamber as improper seating will introduce an error. Place the lens retaining ring (53) in position above the lens.

4. Insert one end of a capillary tube, about six inches long, into the hole reamed for the taper pin. The end of the tube should taper to fit snugly into the hole. The other end should be dipped under the surface of a quantity of Xylene, Spec. AN-R-X-876. The whole setup should then be placed into an air

tight chamber and subjected to a partial vacuum for about 20 minutes. A pressure of 25 or less millimeters of mercury is satisfactory. By this process the chambers are evacuated and air is also removed from the liquid. As an added precaution, it is advisable to subject the liquid, previous to filling the chamber, to the above mentioned partial vacuum for at least 30 minutes.

NOTE: Before filling the bubble cell with liquid, make sure the bubble cell is clean.

5. Allow air to enter the air-tight chamber slowly. This will force the liquid into the bubble cell chamber.

6. Remove the capillary tube and fill the chamber completely with liquid. If a small air bubble remains in the chamber, the cell should be tilted so that it will pass out through the taper pin opening and the cell is completely filled with liquid.

7. Place the taper pin plug (70) tightly into reamed opening. It should not be tapped into place, but pushed in tightly while being rotated.

8. Set the ring (73) in place and fasten with the three screws (74). If necessary, repaint the luminous surfaces of the ring.

9. Replace the diaphragm cap assembly (75) with the diaphragm nut (76) onto the bubble chamber.

(b) TO REASSEMBLE EYEPIECE PRISM ASSEMBLY.

1. Set the eyepiece lens (64) into the eyepiece lens housing and fasten in place with the eyepiece bezel (66) using eyepiece bezel wrench (PQ-6003).

NOTE: Care must be taken not to tighten the bezel excessively as this may crack the lens.

2. Place the eyepiece lens ring and housing assembly into the eyepiece prism carrier (56) and secure in place with the three short ring retaining screws (59) and one long housing retaining screw (67).

3. Set the eyepiece buffer mounting assembly (62) on the lens ring and housing assembly and fasten in place with the mounting spring (65) and eyepiece nut (63). Use the eyepiece nut wrench (PQ-6002) to tighten the eyepiece nut.

4. Place the eyepiece prism (58) into the prism carrier (56) and secure in position with the six prism screws (57). Fasten the prism retaining ring (54) on the bottom of the prism carrier with four screws (68).

(c) TO REASSEMBLE OBJECTIVE LENS ASSEMBLY.

1. Place the objective lens (108) and spacing ring (106) into the objective tube assembly (105) being careful to place the front surface of the lens in its correct position. The front surface of the lens was marked at disassembly.

NOTE: If it becomes necessary to replace either the spacing ring or the objective lens, these parts must be replaced as a unit with the objective lens and ring assembly (PB-25033-1).

2. Place the lens retaining ring (104) and diaphragm (94) into the objective tube assembly (105) and fasten in place with the lens lock ring (93) using lens lock ring wrench (PQ-6001). Make sure the hole in the lens ring is aligned with the hole in the objective tube assembly.

(d) TO REASSEMBLE ASTIGMATIZER LENS AND GLASS IN ASTIGMATIZER PLATE.

1. Replace the astigmatizer glass (50) into the opening in the astigmatizer plate and fasten in place with the astigmatizer lens nut (46) using the lens nut wrench (PQ-6004). Secure in place with the set screw.

2. Replace the astigmatizer lens (88) into the mounting ring (89) and secure in place with the spacing ring (80) and astigmatizer lens nut (91) using lens nut wrench (PQ-6004).

3. Replace the mounting ring (89) with the astigmatizer lens (88) into

the astigmatizer plate assembly (47). Replace the set screw (90) that secures the mounting ring.

NOTE: Do not tighten the set screw. Final adjustment of the lens will be made during calibration of the telescope assembly.

(e) TO REASSEMBLE TELESCOPE CASTING ASSEMBLY.

1. Place the roof prism (77) and roof prism support (79) into the telescope body (78) and tighten in place with roof prism support screw (81). Adjustment of the roof prism will be made at calibration of the telescope assembly.

2. Slide the astigmatizer plate assembly (47) into the bushing in the telescope body.

3. If the astigmatizer control knob (48) has been removed, screw the knob into the astigmatizer plate assembly and place the astigmatizer knob adjusting screw (49) into the knob. Be sure the knob adjusting screw in the knob is parallel to the length of the slot in the telescope casting.

4. Hook the astigmatizer spring (38) to the pin on the astigmatizer plate and to a similar pin on the astigmatizer cover and fasten the astigmatizer cover assembly (92) to the telescope casting with the three screws (45).

5. Slide the objective lens assembly into the tube of the astigmatizer cover assembly (92) and temporarily secure it in place with the set screw. Final adjustment of the objective lens assembly will be made during calibration of the telescope assembly.

(f) TO REASSEMBLE EYEPIECE PRISM ASSEMBLY TO BUBBLE ASSEMBLY. - Place the spring washer and retainers (51) in place around the raised step of the bubble chamber. Rotate retainers to an intermediate 45° angle with respect to the telescope body. Place the eyepiece prism assembly in position over the retainers and fasten the eyepiece prism assembly to the retainers (51) with the four screws (69). The eyepiece assembly must be free to rotate.

(g) TO REASSEMBLE BUBBLE AND EYEPIECE PRISM ASSEMBLIES TO TELESCOPE CASTING ASSEMBLY. - Place the bubble and eyepiece prism assemblies in position on telescope casting assembly. Rotate the eyepiece prism assembly to a 45° angle with respect to telescope body and screw the four screws (52) into the top of the bubble chamber. Insert two screws (82) in holes on the left side of the bubble chamber and tighten them securely.

(h) TO CALIBRATE TELESCOPE ASSEMBLY.

1. Set the telescope assembly on a horizontal collimator adjusted to give parallel rays of light on the same plane as that occupied by the bubble or sight on a distinct distant object 800 or more feet distant.

2. Form a bubble in the bubble chamber and focus the eyepiece sharply on the bubble. Center the bubble in the middle of the field.

3. Adjust the roof prism (77) in the telescope body (78) so that the image of a vertical object is parallel to the vertical line etched on the field lens (55). To facilitate adjustment of the prism, place a No. 4-48 screw approximately 3/4" long, into the hole in the prism support (79). Loosen the prism support screw (81) and by means of the screw inserted in the prism support, shift the position of the roof prism so that the image is aligned. Tighten the prism support screw securing the roof prism in position and remove the No. 4-48 screw.

4. With the astigmatizer lens (88) in the optical field, note the thickness of the horizontal line of the collimator target. If the astigmatized image of the horizontal line appears thicker than the unastigmatized image, the astigmatizer lens must be adjusted as follows: Loosen the set screw (37) that holds the objective lens assembly in position, and remove the objective lens assembly. Insert the wrench (PQ-6004) into the telescope tube and rotate the mounting ring (89) a slight amount. Replace the objective lens assembly and note the astigmatization of the image. Repeat this procedure until the astigmatized image is as thin as possible.

After the astigmatizer lens (88) is properly adjusted, remove the three cover screws (45) and take the astigmatizer cover assembly (92) with the astigmatizer plate assembly (47) out of the telescope body (78). Tighten the set screw (90), locking the mounting ring (89) in the astigmatizer plate assembly (47). Replace the assemblies into the telescope body (78) and secure the astigmatizer cover assembly (92) in place with the three screws (45). Fine adjustments of the astigmatizer lens are made by moving the set screw (49) on the control knob (48) in or out. Secure the set screw in position with a small amount of shellac when adjusted properly.

5. Adjust the objective lens (108) as follows: Sight on the collimated images or upon a distinct distant object about 800 or more feet distant. Move the eye up and down a small distance and if there is no parallax, i.e., no relative motion between the image and the bubble, the objective lens assembly is properly adjusted. The image and the bubble should both appear sharp. If parallax is present, move the objective lens assembly in or out, enough to eliminate it. Place the set screw (37) in the hole at the top of the telescope and lock the objective lens assembly in position. It may be necessary to file the clearance hole in the telescope tube for the set screw before replacing it after adjustment.

(4) TO REASSEMBLE RIGHT AND LEFT SIDE PLATE ASSEMBLIES (Refer to figure 23).

(a) Guide the spacing pillars on the right side of plate into the holes in the left side plate and fasten with the two nuts (7) and one support screw (13).

(b) Thread the wire from the spring contact assembly on the right side plate through the hole in the left side plate and solder it to the movable contact spring assembly. Guide the wire from the battery rear insulator assembly through the hole in the left side plate and solder it to the stationary contact spring assembly. Refer to wiring diagram figure 26.

(c) Set the left side cover assembly (26) in place on the left side plate and secure with the three screws (25).

(5) TO REASSEMBLE TELESCOPE ASSEMBLY TO RIGHT AND LEFT SIDE PLATES. - Set the telescope assembly carefully between the right and left side plates and secure it in place with the four screws through the right side plate and one screw through the left side plate.

(6) TO REASSEMBLE RIGHT SIDE COVER ASSEMBLY (Refer to figure 24).

(a) Place the scale window into the right side cover and cement it in place with Varnish, Shellac, Spec. TT-V-91.

(b) Mount the worm wheel index in the right side cover so that its index mark is visible through the scale window and secure it in place with the two screws.

(c) Replace the celluloid card (23) so that its cutout is at the scale window and fasten it on the right side cover (22) with the four screws (25).

(7) CALIBRATION OF THE WORM WHEEL (Refer to figure 24).

(a) Temporarily place the right side cover assembly on the right side plate (34) and align the holes in the cover (22) and right side plate (34). Rotate the worm wheel (16) by means of the bushing and worm assembly (1) so that the zero graduation on the worm wheel dial (17) is aligned with the worm wheel index.

(b) Place the worm scale drum (8) on the bushing and worm assembly (1) and lock it on the shaft at zero position with the one nut (9). Remove the right side cover assembly.

(c) Set the sextant on a collimator equipped with collimation tubes located at 9° intervals from 0° to 90° .

(d) Form the bubble and adjust the index and horizon prism carriers.

1. Sight through the index prism (33) and without rotating the scale drum (8) bring the horizontal collimator image into collimation with the bubble by adjusting the index prism carrier (112) as follows:

a. Remove the nut (117) and washer (116) that secure the index prism carrier to the worm wheel support (114) using the hex nut wrench (PQ-4614).

b. Replace the washer with the dowel pin jig (PQ-6068) and tighten in place with a No. 10 steel hex nut whose opposite corners have been filed flat so that hole in the dowel pin jig is accessible.

c. With the scales set at zero, sight through the instrument and note the position of the image in relation to the bubble. Loosen the No. 10 steel hex nut with hex nut wrench (PQ-4614) and rotate the index prism carrier until the image is in collimation with the bubble. When the image through the index prism is in collimation, tighten the nut, securing the index prism carrier in place.

2. If replacement of either the horizon prism carrier or the adjusting plate was necessary, sight through the horizon prism and adjust the carrier as follows, prior to doweling. (Refer to figure 26)

a. Remove the nut (22), lockwasher (23) and washer (24) that secure the horizon prism carrier (27) to the adjusting plate (8) using the hex nut wrench (PQ-4614).

b. Place a No. 10 steel hex nut, whose opposite corners have been filed flat, onto the horizon prism carrier and tighten the nut.

c. Sight through the horizon prism (19) and note the position of the image in relation to the bubble. Loosen the #10 hex nut with the hex nut wrench (PQ-4614) and rotate the horizon prism carrier until the image is in collimation with the bubble. Tighten the nut securing the carrier in place. In order to properly collimate the image it may be necessary to make adjustments with the two mounting screws (21) and adjusting screws (9) on the adjusting plate (8).

3. Remove the instrument from the collimator and locate the holes for the dowel pins as follows:

a. Using the hole in the dowel pin jig (PQ-6068) as a guide, drill a hole $5/32$ " deep into the worm wheel support and index prism carrier with a #53 drill. Remove the steel nut and the dowel

pin jig. Ream the hole, if necessary, for a press fit with the dowel pin and insert the dowel pin (118) into the hole. Replace the washer (116) and nut (117) originally on the carrier (112) and tighten the nut with the hex nut wrench (PQ-4614).

NOTE: Care must be taken to prevent chips from falling into the worm wheel support bearing and the worm wheel teeth.

b. Drill two holes 180° apart, and $5/32$ " deep on a $5/32$ " radius as shown in figure 23 into the adjusting plate (8) using a No. 53 drill. Ream the holes, if necessary, for a press fit with the dowel pins. Insert the pins (17) into the holes. Remove the steel nut, replace the washer (24), lockwasher (23) and the nut (22) originally on the carrier (27) and tighten the nut with the hex nut wrench (PQ-4614).

NOTE: Remove all chips from the left side plate.

(e) Place the instrument on the collimator. With the bubble in the center of the field, sight through the instrument and by rotating the scale drum, bring the image from the horizontal collimator tube into collimation with the bubble. Note the reading on drum. Rotate the drum until the image from the 90° collimator tube is in collimation with the bubble. Note the reading on the drum.

(f) The reading for the 90° collimated image must be the same as the reading for the horizontal collimated image, i.e., $90^\circ 5'$ for the 90° position and $5'$ for the horizontal position or $89^\circ 54'$ for the 90° position and $-6'$ for the horizontal position. If error exists at the 90° position it will be corrected as follows:

1. If the error is plus i.e., $90^\circ 7'$ at 90° position and $3'$ at the horizontal position, loosen the lock screws (20) and by means of the worm wheel adjusting wrench (PQ-6000) loosen the adjusting screws (18) a slight amount each. Tighten the lock screws.

2. If the error is minus i.e., $90^\circ 7'$ at 90° position and $10'$ at the horizontal position, loosen the lock screws and by means of the worm wheel

adjusting wrench (PQ-6000) tighten the adjusting screws a slight amount each. Tighten the lock screws.

(g) In either of the above cases, after the adjusting screws have been either tightened or loosened, the following procedure should then be followed:

1. Rotate the drum counterclockwise until the image from the horizontal collimator tube is in collimation with the bubble and note the reading. Then rotate the drum clockwise until the image from the 90° collimator tube is in collimation with the bubble and note the reading.

2. If the reading is the same, the end variations are equalized. If the reading is either plus or minus the adjusting screws will have to be tightened or loosened as described above, whatever the case may be, and this procedure repeated until the variations are equalized at the horizontal and 90° position, which are the end positions of the worm wheel.

(h) After the variations have been equalized at the ends, the worm wheel will have to be checked at each of the 9° intervals as follows:

1. Rotate the drum until the image from the 9° collimator tube is in collimation with the bubble and note the reading. Continue this procedure until a reading has been taken for each of the collimator tube images from 9° to 90° .

2. The reading at each of the 9° points from 9° to 90° must be the same within the tolerance of two minutes. For example, if the reading at the horizontal position was 5' then at 72° position the reading may be $72^{\circ} 7'$ or $72^{\circ} 3'$ which are still within the 2 minute tolerance. When the reading at each of the points is within the two minute tolerance, the worm is properly calibrated. If the reading at any of the 9° points is greater than two minutes i.e., when sighting at the image from the 72° collimator tube and upon collimation with the bubble the reading is $72^{\circ} 2'$ or $72^{\circ} 8'$ it will be necessary to loosen the lock screws, and by means of the worm wheel adjusting wrench (PQ-6000) loosen the adjusting screws a slight amount for the plus error i.e., $72^{\circ} 8'$ or tighten the adjusting screws a slight amount for the minus

error i.e., $72^{\circ} 2'$ and then tighten the lock screws. By performing this adjustment the equalization of the extreme ends of the worm wheel will be disturbed, but a variation of one minute at the ends may compensate the error at the interpositions. Eliminate the error at the zero position by readjusting the index prism. Check the error at the 90° position and if the error exceeds 2 minutes, readjustment of the ends of the worm wheel will be necessary.

(i) While calibrating the worm wheel, it is advisable to eliminate excessive play between the worm wheel and the worm. This may be accomplished by tightening the worm shaft plunger screw (31) using the plunger adjusting screwdriver (PQ-4616). There should be a minimum amount of play between the worm and worm wheel.

(j) If there is still excessive play between the worm and the worm wheel after calibration and cannot be minimized by the plunger screw, the following is recommended:

1. Remove the one nut (9) and lift off the scale drum (8) from the bushing and worm assembly (1).

2. Loosen the worm bushing bezel (3) using the bushing bezel wrench (PQ-4695). Press the end of the bushing and worm assembly forward against the worm wheel and gradually tighten the bushing bezel with the fingers. By feeling the amount of play, the bushing and worm assembly will be moved accordingly. When there is a minimum amount of play, lock the worm bushing bezel in place with the bushing bezel wrench (PQ-4695). If the play is insufficient, the gear action will be stiffer causing excessive friction between the worm and worm wheel. A greater force will be necessary to turn the drum. This may be corrected by loosening the worm shaft plunger screw.

(k) When the worm wheel has been calibrated within the tolerances and the backlash kept at a minimum, place some shellac on the plunger plug (32) and screw in place on the right side plate. Place the right side cover assembly on the right side plate and secure in place with the three screws (24).

(8) TO REASSEMBLE WORM SCALE DRUM ASSEMBLY.

(a) Fasten the scale drum brake assembly (5) on the right side plate (34) with the two screws (4).

(b) Secure the lower stop washer (6) on the right side plate with the three screws (14). Be sure the protrusion of the washer is in the correct position as indicated by the mark scribed on the casting at disassembly.

(c) Place the 23 intermediate stop washers (13) on the shaft of the bushing and worm assembly (1) so that the protrusions of the stop washers face downward. To provide the .003" to .005" clearance between the lubber line ring (15) and the scale drum assembly (8) it may be necessary to insert spacing washers (12) between the stop washers (13) so that the clearance is taken up, yet the washers must be free to rotate. The number of spacing washers may vary from none to twenty and in no case will more than one spacing washer be used between any two stop washers.

(d) It is important that the upper stop washer (11) be properly located in the scale drum (8) as this determines the stop positions of the worm wheel. The overtravel of the worm wheel should be limited to about 7° beyond the 0° and 90° positions. This is accomplished as follows: Rotate the worm wheel (16) by means of the bushing and worm assembly (1) so that the worm scale dial (17) visible through the scale window reads zero. Rotate the stop washers in a counterclockwise direction, without altering the position of the bushing and worm assembly, so that the protrusions of the stop washers are in contact with each other. Hold the scale drum so that the 2° graduation is aligned with the reference mark on the lubber line plate and note the position that the upper stop washer (11) will have to occupy in the scale drum (8) when the protrusion of the upper stop washer (11) is in counterclockwise contact with the other stop washers. With the washer (11) in this position, secure the upper stop washer in the scale drum with the three screws (7). Place the scale drum on the bushing and worm assembly and rotate the drum counterclockwise until the upper stop washer makes contact with the other stop

washers. The 2° graduation should be approximately in line with the reference mark on the lubber line plate. The drum should then be rotated approximately 7° clockwise until the 0° graduation on the scale drum is aligned with the reference mark. Lock the scale drum (8) in zero position with the two nuts (9) and screw the scale drum cover (10) on the scale drum. The bushing and worm assembly must not be moved during this operation as this will result in an incorrect setting of the stop position.

NOTE: The above adjustments of the stop positions will be facilitated if the location of the protrusions of the upper and lower stop washers are marked on the scale drum and right side of plate respectively at disassembly.

(9) FINAL ADJUSTMENTS.

(a) For these adjustments an accurately set horizontal collimator or natural horizon should be used. If a collimator is used, it should preferably have a horizontal collimation line. If no collimator is available, a light or line some 800 or more feet distant, exactly at the same height as the sextant may be used. The light or line should be located by means of a transit or surveyor's level. For convenience, the sextant must be clamped to some rigid structure during the checking and readjustment operations. The bubble, about $3/32$ " in diameter must be formed and be approximately in the middle of the field. If the natural horizon is used, correction for the "Dip of the Horizon" must be applied.

(b) With both scales set at zero, the horizon shutter knob in its extreme position in the direction opposite to the arrow, and the proper size bubble in the center of the field, note the position of the image in respect to the bubble. Adjust the index prism until the image is brought into collimation with the bubble. This adjustment is made by tightening one and loosening the other of the two prism adjusting screws (110, figure 24) on the underside of the prism carrier using the prism adjusting hook (PQ-3152). Upon completion of this adjustment, the adjusting screws must be tight but not tight enough to put excessive strain on the prism.

(c) With the horizon shutter knob in its extreme position in the direction indicated by the arrow, note the position of the image with respect to the bubble. Adjust the horizon prism in the same manner as performed for the index prism outlined in the previous step.

(d) It may also be necessary to adjust the prisms for horizontal coincidence, that is the images of some vertical object do not coincide exactly. Set up the sextant with the bubble at the center of the field and sight on a vertical line which passes through the center of the field. If the lateral position of the line shifts when the micrometer drum is turned, the index prism must be adjusted by means of the prism adjusting pivot (109, figure 24) underneath the index prism carrier. The image through the horizon prism must then be adjusted to coincide with the image through the index prism. This is accomplished by removing the left side cover assembly and loosening one and tightening the other of the two mounting screws (21, figure 23) that secure the adjusting plate (8, figure 23) to the left side plate.

(e) Set the instrument on the horizontal collimator so that the bubble will be in the center of the field. Focus the eyepiece sharply on the bubble. Sight through the index prism and adjust the size of the bubble so that it is tangent to the two horizontal target lines of the collimator. Tilt the instrument so that the bubble will travel 4° above and below the center of the field and note the motion of the bubble and the target line relative to each other. If one moves faster than the other, i.e., the bubble is no longer tangent to the two horizontal target lines; rotate the index prism by means of the scale drum so that the target lines are tangent. Note the reading of the scale drum. If the error exceeds two minutes and is uniform at the 4° points above and below the center of the field, refocus the objective lens assembly in accordance with the procedure outlined in paragraph 4. a. (3) (h), Calibration of Telescope Assembly, this section. If the error exceeds two minutes and is not uniform at the 4° points above and below the center of the field, the field lens is not properly seated in the bubble chamber or is distorted.

(10) TO REASSEMBLE BJ-4 AVERAGING DEVICE (Refer to figure 22).

(a) To reassemble pencil assembly:

1. Slide the spring (2) into the pencil housing (1) and insert the sleeve and pin assembly (13). Push the assembly against the tension of the spring so that the pin (3) will pass the snap ring groove in the pencil housing. Hold it in this position and replace the snap ring (4).

2. Press the collet (25) into the sleeve and pin assembly. Insert the pencil lead (24) into the collet and secure in place with the sleeve (12).

(b) Insert spherical end of the trip pin (20) through the hole on the left side of the base plate (10). Slide the trigger spring (21) and the stop (8) onto the trip pin (20). Then continue the spherical end of the trip pin into the hole on the right side of the base plate. Align the holes in the stop and the trip pin and pin in place with the taper pin (7).

NOTE: If either the stop or the trip pin have been replaced, the taper pin hole will have to be located after the averaging device is completely assembled and mounted on the sextant.

(c) Place the ratchet spring (19) on the stop and secure it in place with the screw (15) and lockwasher.

(d) Place the ratchet stop spring (9) in position on the base plate and secure it with the screw (11) and lockwasher.

(e) Replace the stop screw (14) into the base plate and secure in place with the nut (17).

(f) Insert the detent spring (29) and the steel ball (27) in the hole provided for them in the base plate. Place the ratchet (18) on the base plate and set the ratchet pivot (16) in place holding the ratchet. Swing the ratchet spring (19) and ratchet stop spring (9) in position on the ratchet (18). Tighten the screws that hold the springs.

(g) Place the cover (28) onto the base plate (10) and fasten it with the screw (26).

(h) Mount the trigger (6) on the base plate and lock in place with the stud (22).

(11) TO REASSEMBLE BJ-4 AVERAGING DEVICE ONTO SEXTANT.

(a) Place the sextant on the bench so that the right side is facing upward. Place the averaging device in position on the right side plate. Place the two screws (30) into the holes in the base plate and screw them into place.

(b) Press the trigger (6) backward and insert the screw (5) through the cutout on the trigger into the hole in the base plate.

(c) Screw the pencil assembly into the trigger housing.

(12) FINAL ADJUSTMENT OF BJ-4 AVERAGING DEVICE.

(a) If either the stop (8) or the trip pin (20) is replaced with a new part, a new hole for taper pin (7) must be located. Remove the two screws (30) and swing the cover (28) to one side so that the stop is accessible. Drill the .052" hole in the stop through the trip pin and out the other end of the stop using a No. 55 drill. Locate the hole so that the pencil (24) is in the position indicated by the broken lines as shown in figure 22. Ream the hole, if necessary, and insert the taper pin (7) through the stop (8) and trip pin (20).

NOTE: Care must be taken not to damage the instrument when drilling the hole.

(b) Adjust the travel of the pencil to that shown in figure 22 by loosening the nut (17) and adjusting the screw (14) in or out of the base plate. Lock the screw in position with the nut.

(c) Swing the cover to its original position on the base plate and depress the trigger a few times. If the tension of the ratchet spring (19) is insufficient to bring the next numeral on the ratchet into view, it may be adjusted by shifting or bending it. If the numerals are not centered in the cutout, the ratchet stop spring (9) may be adjusted by bending it.

(d) Replace the two screws (30) into the base plate (10) and secure them in place. Be sure these screws are tight as they secure the averaging device to the right side plate.

5. FINAL TESTS.

a. SCALE ERROR TEST. - The instrument should be tested for scale error at each two-degree point of the micrometer scale and at each ten-degree point of the main scale with both increasing and decreasing readings. The error at any point must not exceed two minutes of arc. The average difference in the readings obtained for the same points of the scale with increasing readings and with decreasing readings must not exceed one minute of arc. The difference of the readings obtained for the same point of the scale with increasing readings and with decreasing readings must not exceed two minutes of arc at any point of the scale. Scale errors include all errors in the instrument except those due to the bubble, to the shade glasses, and to the astigmatizer if provided. Included in the scale errors are errors due to faulty graduation, to eccentricity, to improper setting of the optical parts, to backlash, and to all other causes which may give errors in the indications of the instrument.

b. BUBBLE CELL CURVATURE TEST. - The instrument must be tested for bubble cell curvature. The error due to imperfect curvature of the bubble cell must not exceed two minutes of arc at any point along the line of sight up to four degrees from the center of the bubble cell. When the bubble image is in the center of the field the bubble cell curvature error is considered to be zero.

c. ARTIFICIAL HORIZON INDEX ERROR TEST. The instrument must be tested to determine the index error of the artificial horizon with the bubble image in the center of the field. The index error shall not exceed two minutes of arc.

d. SHADE GLASS AND ASTIGMATIZER TEST. The instrument must be tested to determine the error due to the shade of glasses. The use of any shade glass shall not introduce a change in the reading of the instrument of more than thirty seconds.