

X

1412

T.O. 5N10-4-2-3

★
TECHNICAL MANUAL
OVERHAUL

**HANDHELD AIRCRAFT SEXTANT
(PENDULOUS MIRROR)**

KOLLSMAN TYPE NO.	AF TYPE	STOCK NO.
1972-02	MA-1	6225-1972-02
1972B-02	MA-1	6225-1972B-02

(KOLLSMAN)

CHANGE
NOTICE

LATEST CHANGED PAGES SUPERSEDE
THE SAME PAGES OF PREVIOUS DATE

Insert changed pages into basic
publication. Destroy superseded pages.

PUBLISHED UNDER AUTHORITY OF THE SECRETARY OF THE AIR FORCE

Reproduction for non-military use of the information or illustrations contained in this publication is not permitted without specific approval of the issuing service (BuAer or USAF). The policy for use of Classified Publications is established for the Air Force in AFR 205-1 and for the Navy in Navy Regulations, Article 1509.

LIST OF EFFECTIVE PAGES

INSERT LATEST CHANGED PAGES. DESTROY SUPERSEDED PAGES.

NOTE: The portion of the text affected by the changes is indicated by a vertical line in the outer margins of the page.

TOTAL NUMBER OF PAGES IN THIS PUBLICATION IS 44 CONSISTING OF THE FOLLOWING:

<i>Page No.</i>	<i>Issue</i>
*Title	15 Apr 59
*A	15 Apr 59
*i	15 Apr 59
ii	Original
*1	15 Apr 59
2 thru 16	Original
*17	15 Apr 59
18	Original
*19 thru 20	15 Apr 59
21 thru 22A	Original
22B Blank	Original
23	Original
*24	15 Apr 59
25	Original
*26 thru 27	15 Apr 59
28	Original
*29	15 Apr 59
30 thru 33	Original
34 Blank	Original
*35	15 Apr 59
*36 Blank	15 Apr 59
*37	15 Apr 59
*38 Blank	15 Apr 59

* The asterisk indicates pages changed, added or deleted by the current change.

ADDITIONAL COPIES OF THIS PUBLICATION MAY BE OBTAINED AS FOLLOWS:

USAF

USAF ACTIVITIES.—In accordance with T.O. 00-5-2.

NAVY ACTIVITIES.—Submit request to nearest supply point listed below, using form NavAer 140; NASD, Philadelphia, Pa.; NAS, Alameda, Calif.; NAS, Jacksonville, Fla.; NAS, Norfolk, Va.; NAS, San Diego, Calif.; Aviation Supply Annex, NSD, Guam.

For listing of available material and details of distribution see Naval Aeronautics Publications Index NavAer 00-500.

Changed 15 April 1959

TABLE OF CONTENTS

Section	Page
I INTRODUCTION.....	1
II OVERHAUL INSTRUCTIONS.....	1
2-1. Overhaul Tools Required	1
2-2. Disassembly	3
2-7. Cleaning (Sextant Averager)	5
2-9. Inspection (Sextant Averager)	5
2-11. Repair or Replacement (Sextant Averager)	5
2-33. Lubrication (Sextant Averager)	11
2-35. Reassembly (Sextant Averager)	11
2-46. Disassembly (Sextant)	17
2-49. Cleaning (Sextant)	18
2-53. Inspection (Sextant)	19
2-55. Repair or Replacement (Sextant)	19
2-90. Lubrication (Sextant)	28
2-92. Reassembly (Sextant)	29
III TEST PROCEDURES.....	32

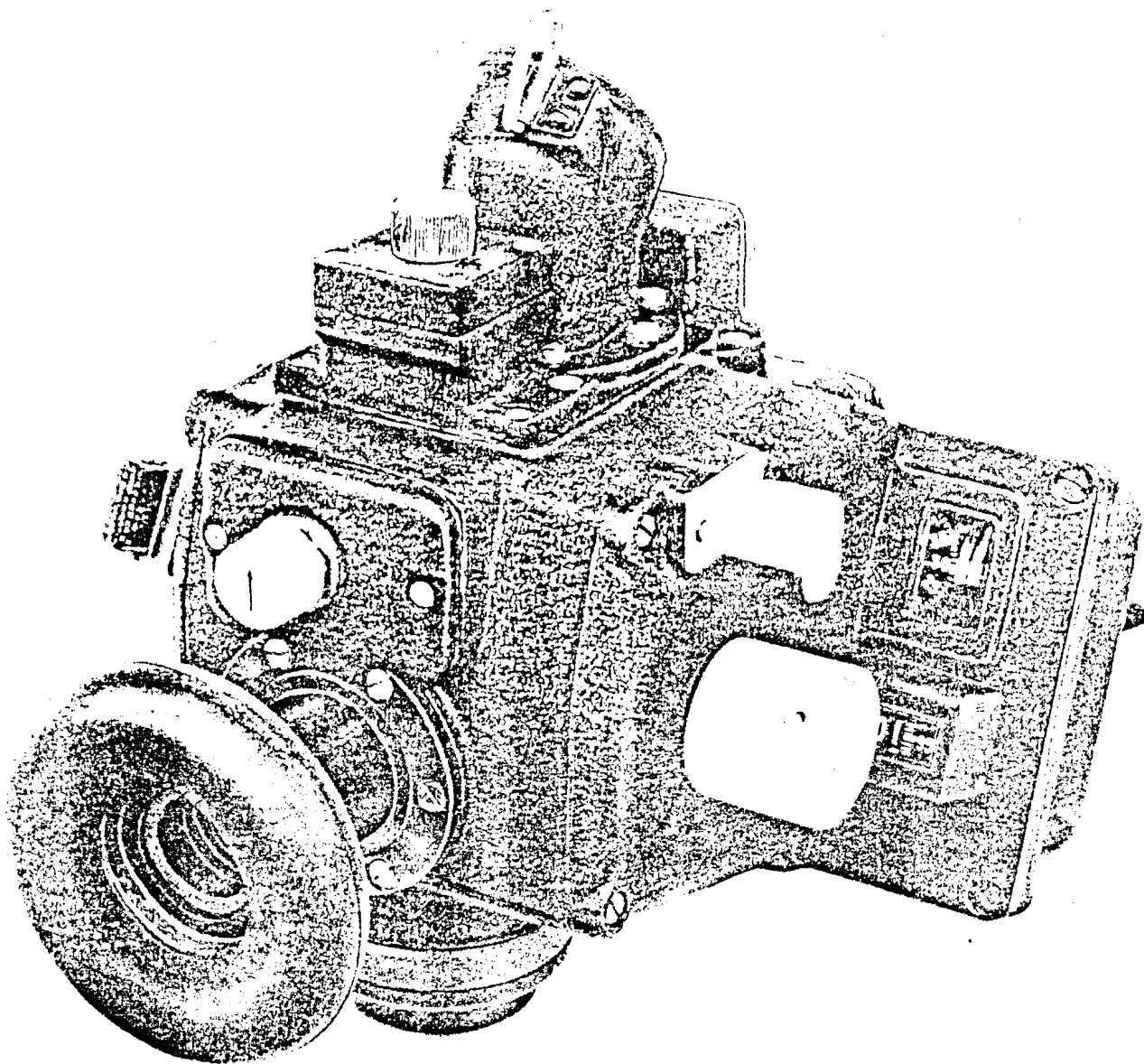

Figure 1-1. Handheld Aircraft Sextant, Kollsman Type 1972-02, Air Force Type MA-1

SECTION I INTRODUCTION

1-1. INTRODUCTION.

1-2. This publication covers the overhaul and test procedures of the Handheld Aircraft Sextant, manufactured by the Kollsman Instrument Corporation, Elmhurst, New York. (See figure 1-1.)

1-3. The following is the instrument designation.

Kollsman Type Number	Air Force Type Number	Air Force Stock Number
1972-02	MA-1	6225-1972-02

1-4. Sections II and III of this handbook contain overhaul and test instructions for Kollsman type 1972-02, Handheld Aircraft Sextant. Overhaul and test instruc-

tions for additional models are included in Section IV by use of Difference Data Sheets.

1-5. PURPOSE OF EQUIPMENT. The Handheld Aircraft Sextant is designed to give indication of the angular altitude of celestial bodies for navigation of aircraft.

LEADING PARTICULARS

ALTITUDE: -10° to $+92^{\circ}$

VOLTAGE: 28 volts

CONTROL: One knob, 5° per revolution

WEIGHT: 6 pounds

SEALING: Sealed against moisture and fungus

SECTION II OVERHAUL INSTRUCTIONS

2-1. OVERHAUL TOOLS.

Class Code	Tool No.	Nomenclature	Application	Figure No.
8073	TE5161	Spanner Wrench	Adjusting the mounting plate eccentric of the averager.	2-1
7800	TE5162A	Pressure Fixture	To test index housing for leak.	2-2
	TE5163	Altered Sextant Body	Used when adjusting and testing the averager.	2-3
8073	TE5167A	Adjustable Assembly Stand	To hold sextant during assembly.	2-4
8073	TE5189B	Index Prism Mount Wrench	To remove index prism mount.	2-5
	TE5194D	Collimator	To collimate sextant.	2-6
	TE5791	Torque Rod	To adjust spring tension of universal.	2-7
	TE5950	Eyepiece Wrench	To remove and to install eyepiece.	2-8
	TE5998	Single Collimator	To adjust optics.	2-9
	TE5952	Tube Wrench	Removal of lock rings.	2-10
	TE5953	Tube Wrenches (2)	Removal of lock rings.	2-11
	TE5954	Holding Fixture	Used with 5194D as a mount for holding sextant.	2-12

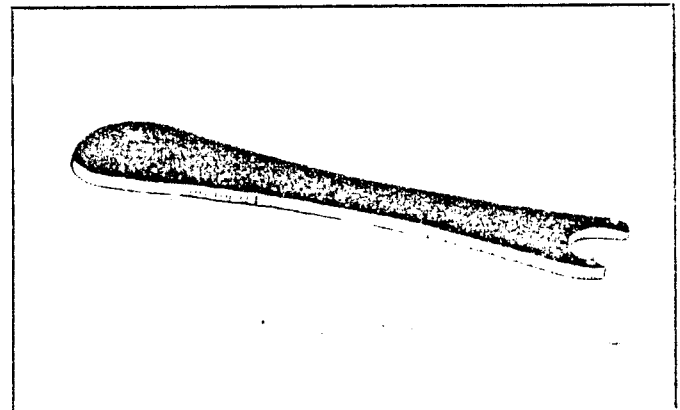

Figure 2-1. Spanner Wrench

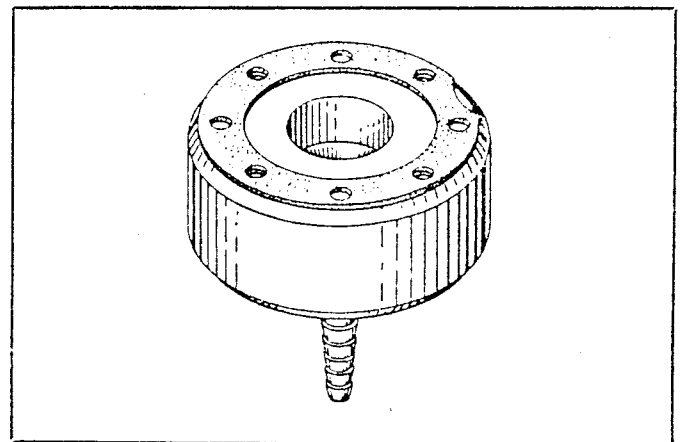

Figure 2-2. Pressure Fixture

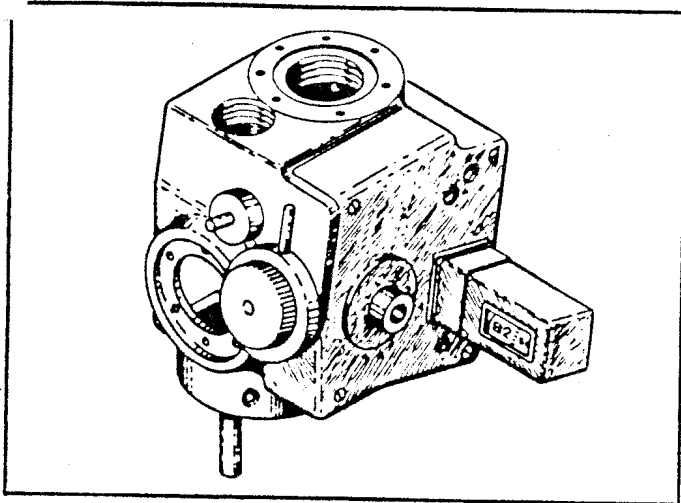

Figure 2-3. Altered Sextant Body

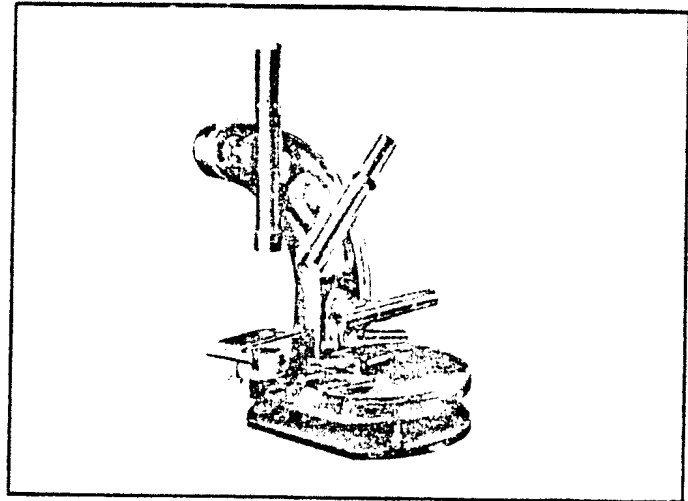

Figure 2-6. Collimator

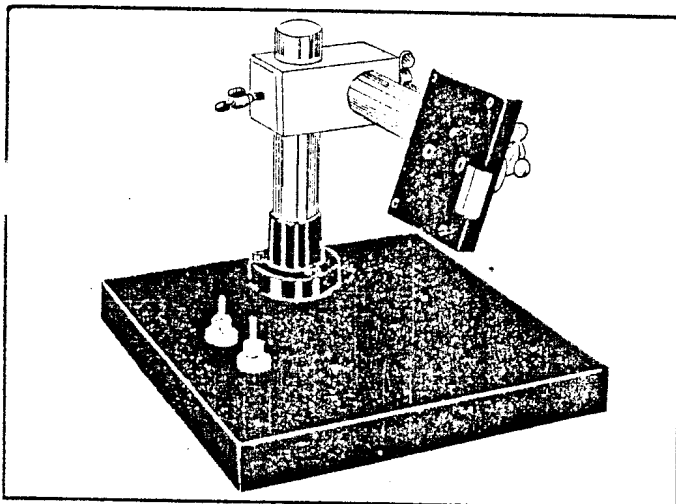

Figure 2-4. Adjustable Assembly Stand

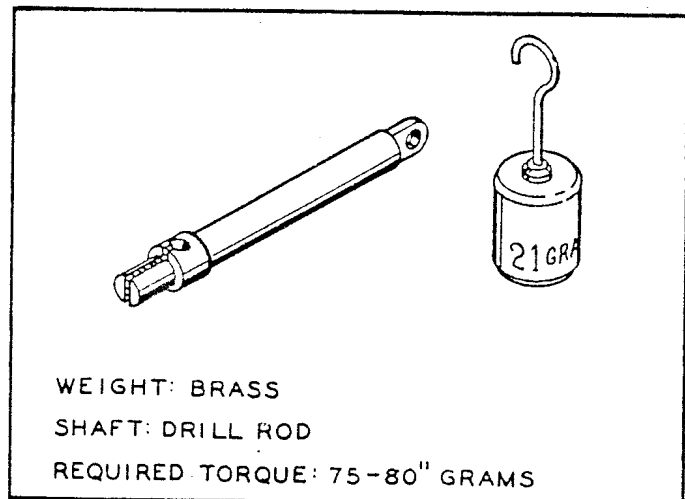

Figure 2-7. Torque Rod

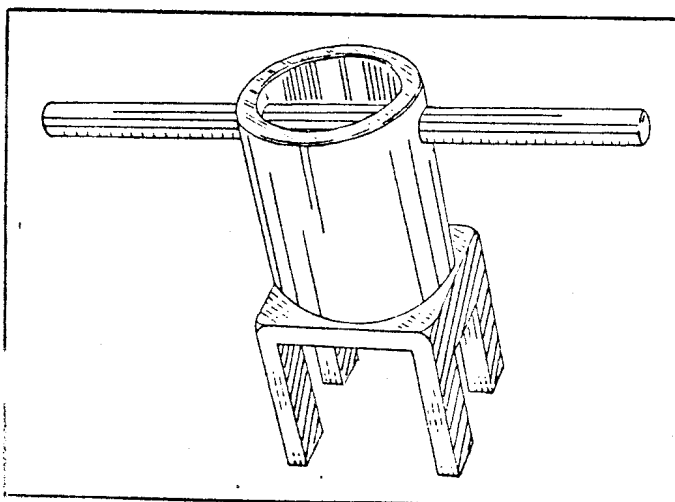

Figure 2-5. Index Prism Mount Wrench

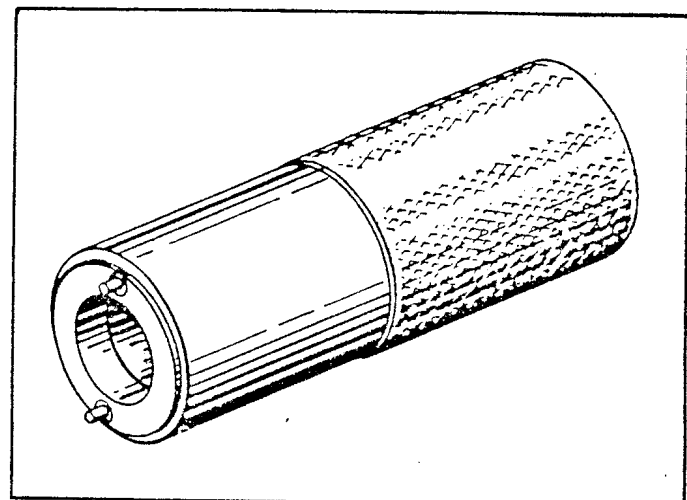

Figure 2-8. Eyepiece Wrench

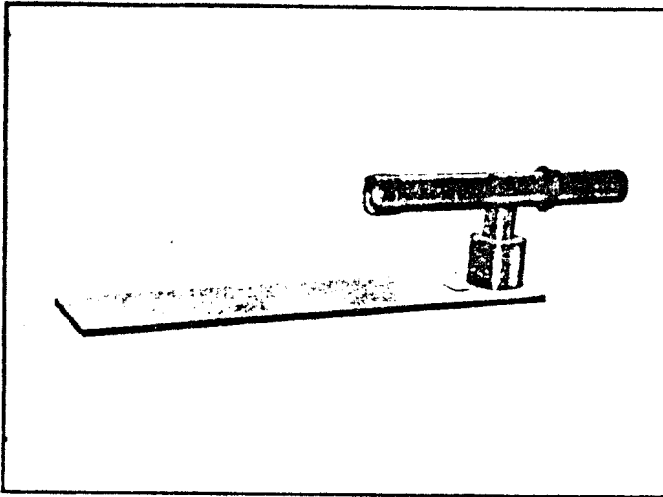

Figure 2-9. Single Collimator

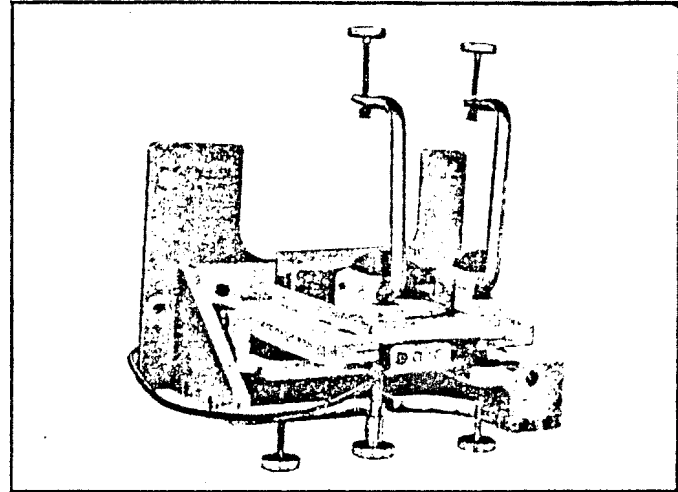

Figure 2-12. Holding Fixture

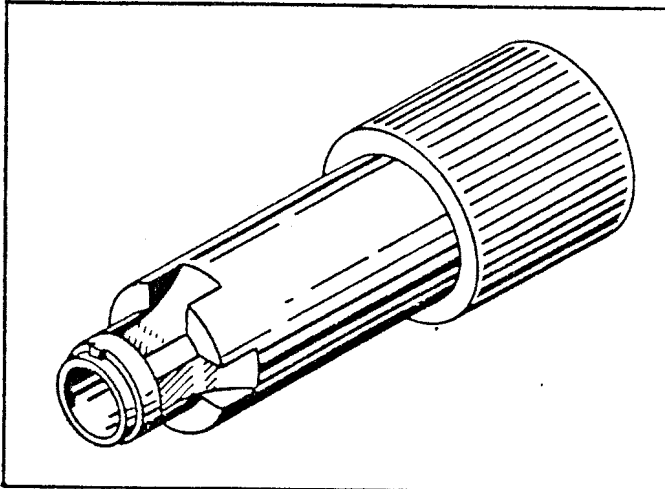

Figure 2-10. Tube Wrench

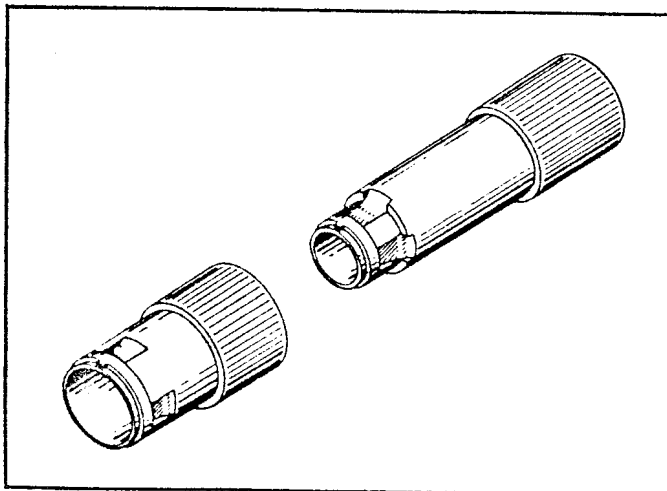

Figure 2-11. Tube Wrenches

2-2. DISASSEMBLY.

2-3. GENERAL. Due to the complexity of the equipment involved, the overhaul procedure is separated into two parts; the averager and the sextant. The final checking of the sextant includes the averager assembly.

2-4. TROUBLESHOOTING. Prior to disassembly an attempt should be made to isolate the component which is at fault. The following will aid in determining which component should be overhauled.

a. If the collimating equipment which is necessary to check the sextant at 0° , 45° and 90° is not available, the sextant may be checked at one or two points by sighting on a distant target. The angle of elevation of the target must first be established by using a surveyor's transit or suitable sighting device.

b. Set the transit up in the normal manner so as to have an unobstructed view for at least 800 feet.

c. Select an object which for all practical purposes may be considered immovable and permanently secure a target on this object at zero altitude when sighting through the transit.

d. The sextant should be securely mounted adjacent to the transit so that its objective window is at the same level as the transit telescope.

e. Rotate the adjustment knob and position the sextant until the artificial horizon, field lens reticle and the target are coincident. The altitude counter on the sextant should indicate the value shown on the correction card for zero altitude. As a further check, a second target may be mounted some distance above the first. A comparison of reading between the transit and the sextant should not differ by more than two minutes of arc. If the errors exceed the tolerance either the sextant is out of collimation or the coupling has shifted on the counter shaft. Before accepting the former, the latter should be investigated and, if necessary, corrected.

f. Remove the counter from the right cover by removing the two screws.

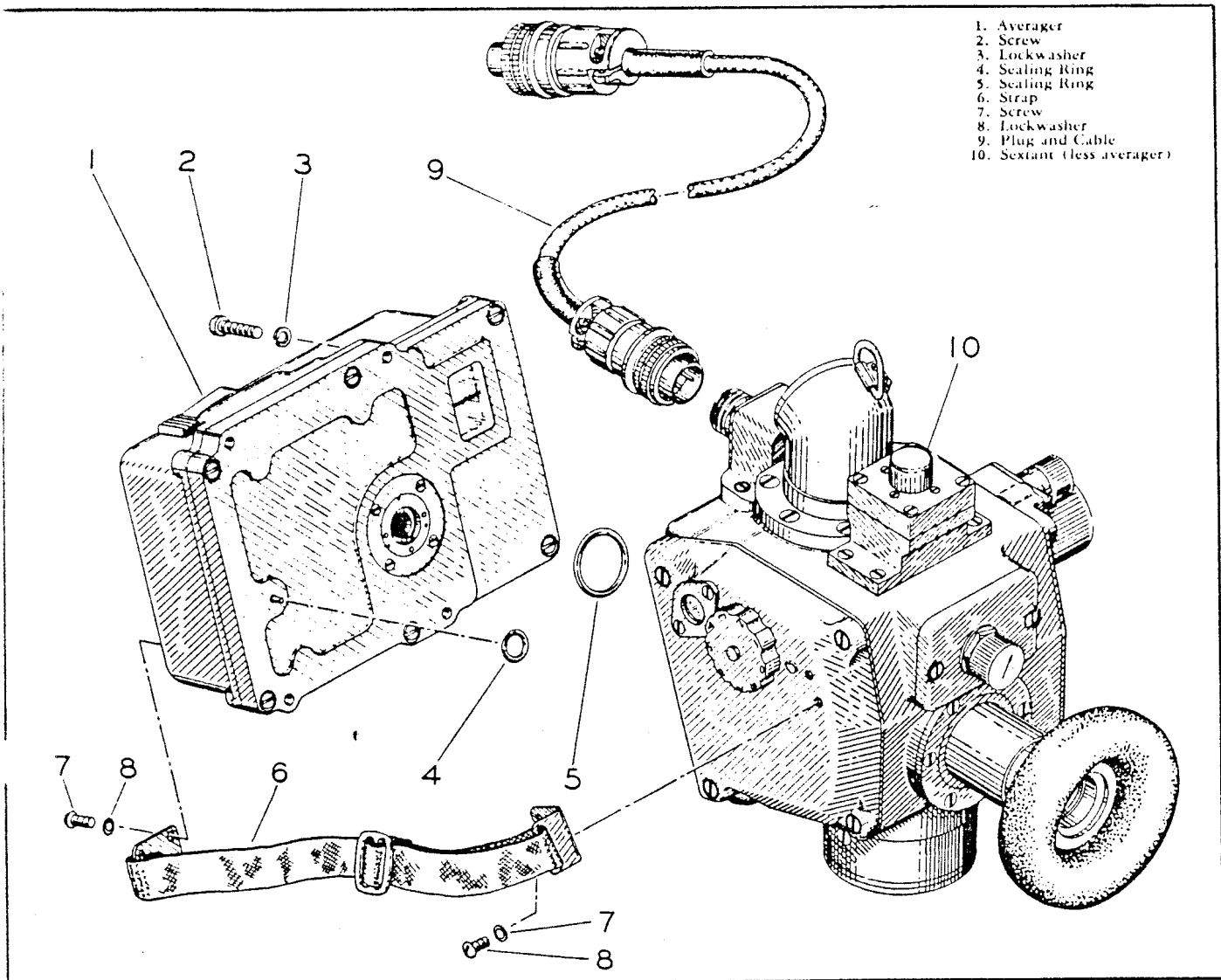

Figure 2-13. Handheld Aircraft Sextant

CAUTION

A floating disk which is used between the counter and the pinion shaft assemblies may or may not fall out of the sextant body when the counter is removed. In any event, the disk must not be lost.

g. Adjust the position of the sextant so that the artificial horizon, the reticle of the field lens and the zero target are coincident. Loosen the two set screws which hold the coupling on the counter shaft and position the coupling so that when it is meshed with the floating disk of the pinion shaft, it will indicate the reading of the correction card. Secure the coupling on the counter shaft and replace the counter on the right cover. Repeat the test until the readings satisfy the tolerances. If the read-

ings cannot be brought within the specified tolerances, it may be assumed that the instrument is out of collimation.

h. To determine which component is at fault, remove the averager assembly from the sextant and check its operation as described in paragraphs 3-11 through 3-22. Place the sextant in a collimating stand and check the calibration as described in paragraphs 3-5 through 3-8. If the sextant calibration is unsatisfactory, proceed to overhaul the equipment.

2-5. REMOVING THE AVERAGER FROM THE SEXTANT. (See figure 2-13.)

a. Place the sextant on an assembly stand with the averager in a horizontal position.

b. Remove four screws (7), lockwashers (8) and lift off strap (6).

c. Remove four screws (2), lockwashers (3) and lift off the averager (1).

d. Remove the two sealing rings (4 and 5).

2-6. DISASSEMBLY OF THE AVERAGER. (See figure 2-14.) Except for attaching parts the disassembly procedure will follow the order of the index numbers assigned to the exploded view.

CAUTION

If more than one mechanism is being overhauled, keep the parts separated or identify the major components as belonging to a particular mechanism. There are many assemblies which are fitted or aligned to its particular mechanism frame and are not readily interchangeable.

2-7. CLEANING.

2-8. GENERAL. Clean all metal parts in Xylene (Federal Specification TT-X-916).

a. Polish pivots and jewels.

b. Gear teeth may be cleaned by brushing lightly with cleaning solution.

c. Clean ball bearings in Xylene (Specification TT-X-916). Remove bearing from solution and hold with tissue while drying with clean air.

2-9. INSPECTION.

2-10. GENERAL. Inspect all metal parts for wear or corrosion and gaskets for deterioration.

2-11. REPAIR OR REPLACEMENT.

2-12. YOKE AND INDEX ASSEMBLY. (See figure 2-15.) Malfunctioning of the yoke and index assembly can usually be traced to one of the following items.

- a. Sticky or rough ball bearings.
- b. Improper fit of the ball bearing on the drum or in the yoke casting.
- c. Improper mesh of the gear train.
- d. Improper setting of the gear retaining clips.
- e. Faulty index assembly.

2-13. DISASSEMBLY OF THE YOKE AND INDEX ASSEMBLY. (See figure 2-15.) Except for attaching parts and, as noted below, disassembly will follow the order of the index numbers assigned to the exploded view.

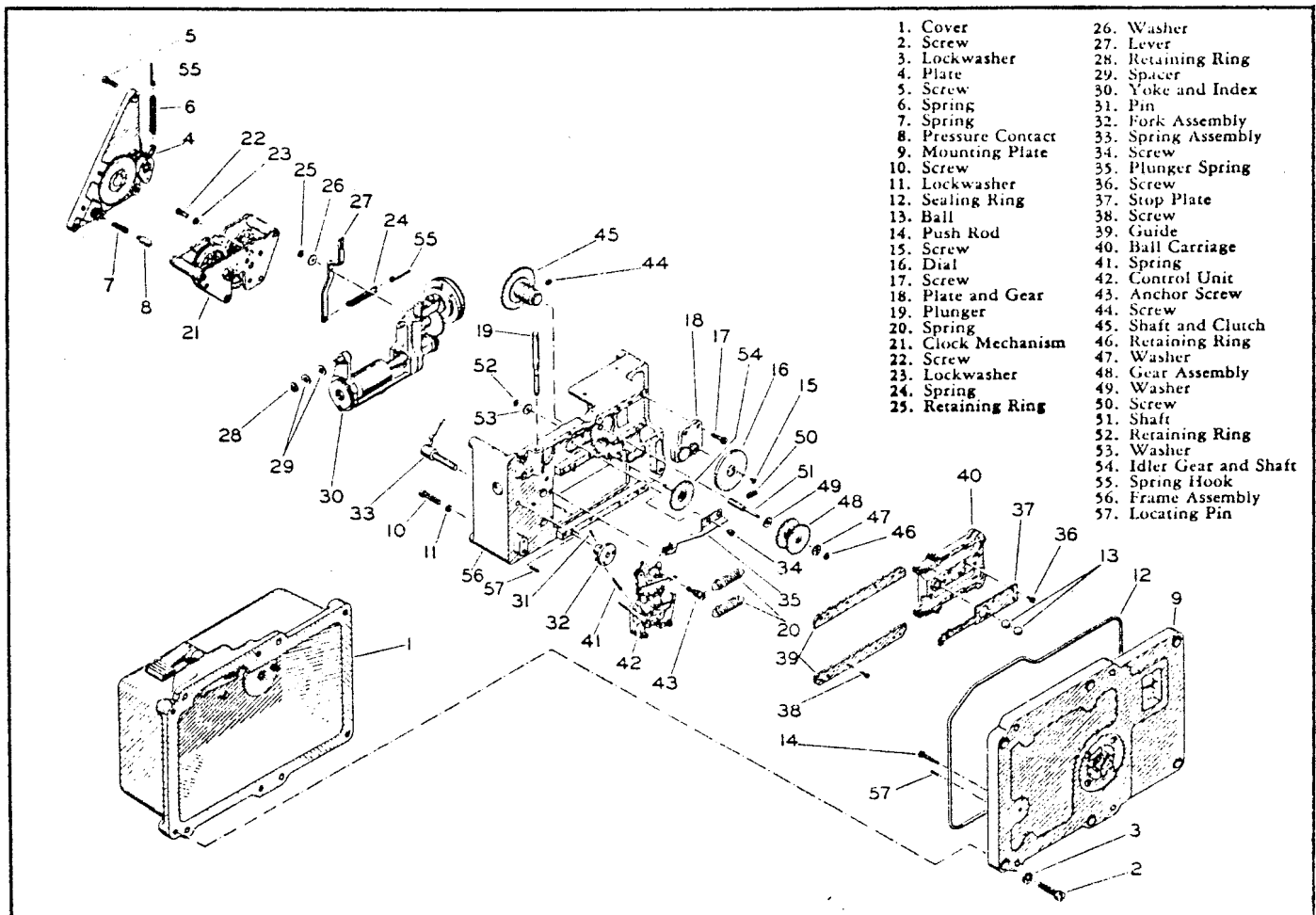

Figure 2-14. Averager Assembly

Section II
Paragraphs 2-13 to 2-14

T.O. 5N10-4-2-3

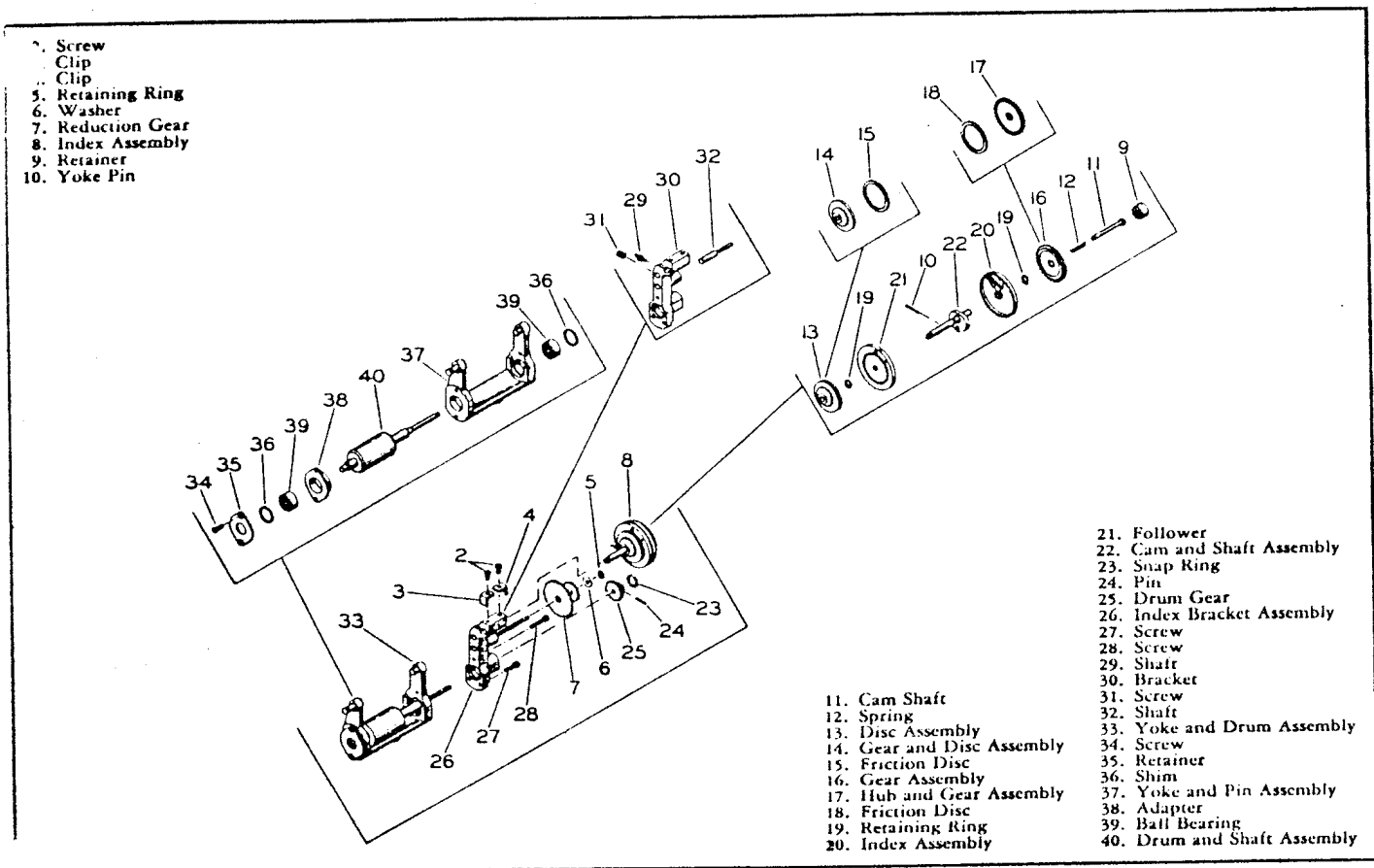

Figure 2-15. Yoke and Index Assembly

- a. Disassemble parts two through seven.
- b. Remove index assembly (8).
- c. Rotate the index disks on the shaft and then release. The spring pressure of the roller and arm assembly should be sufficient to return each disk to the zero position (low position on the cam) with a sharp, clean movement. The disk should not "hang" on the high position of the cam. Check each disk individually since there can be no failures on this test.
- d. Hold the cam and shaft assembly (22) and push the yoke pin (10) to the end of the slot toward the index disks. There should be approximately 0.010 inch clearance between the index disk and the cork of the gear assembly (16).
- e. While holding the index assembly (8), unscrew the retainer (9).
- f. With a suitable punch, drive the yoke pin (10) out of the cam shaft (11).
- g. Remove the cam shaft (11), spring (12), disk assembly (13), and the gear assembly (16).
- h. Further disassembly follows the order of the index numbers assigned to the exploded view.

2-14. REPLACEMENT OF CORK RINGS. (See figure 2-15.) If new friction disks (15 and 18) are to be used on the friction gear and disk assembly (14) and

the hub and gear assembly (17), they must be reduced to a thickness which will permit satisfactory operation of the index assembly (8). The following steps describe the necessary procedure.

- a. Remove the old cork friction disks with a razor blade. Clean the surface of the gear and disk assembly (14) or the hub and gear assembly (17) thoroughly to remove all traces of cork or cement.
- b. Coat the mating surfaces of each part with a thin film of Armstrong's J1101 Cement or the equivalent (AF Specification 26544-B).
- c. Allow cement to air dry (20 to 30 minutes).
- d. Assemble parts and clamp.
- e. Bake in oven at 120°C (250°F) for 45 minutes, or 150°C (300°F) for 20 minutes or 175°C (350°F) for 10 minutes.
- f. The excess cork should be removed in the following manner. Insert a shaft, the diameter of which is slightly less than the diameter of the hole, in the friction gear. Place a piece of very fine sandpaper over a suitable hole in a bench block. Insert the shaft through a hole in the paper and into the bench block. The shaft must be perpendicular to the bench block at all times. Rotate the friction gear on the shaft and remove the excess cork from the friction gear assembly (16) to

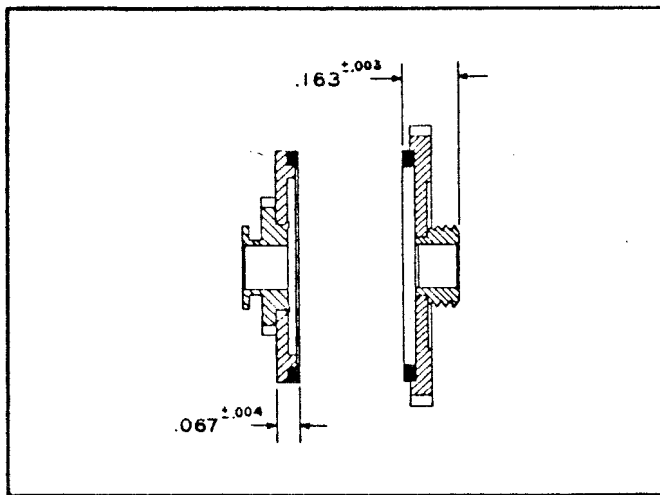

Figure 2-16. Friction Gear Assemblies

satisfy an overall dimension of the assembly of 0.163 ± 0.003 of an inch. (See figure 2-16.)

g. Remove sufficient cork in the manner explained above from the disk assembly (13) to satisfy a dimension of 0.067 ± 0.004 of an inch as measured from the surface of the cork to the back surface of the friction disk. (See figure 2-16.)

h. Check the index disks for operation. Move the yoke pin (10) away from the index assembly and hold it with moderate pressure and, at the same time, rotate the disks. Then release the index disks by moving the pin in the opposite direction. The friction gears should release and permit the index disks to return to the zero position with a clean, sharp action.

CAUTION

Do not use oil on any part of the index assembly.

2-15. ASSEMBLY OF THE YOKE AND INDEX ASSEMBLY. (See figure 2-15.)

a. Except for attaching parts and as noted below, the assembly procedures follow the reverse order of the index numbers assigned to the exploded view.

b. Replace the clips (4 and 3) and secure them with two screws (2). The shaft clip (4) must be an almost line to line fit with the flat of the shaft of the cam and shaft assembly (22). It may be necessary to adjust the clips (4 and 3) and the position of the shaft (32) to prevent disengagement of the gears. The clip must be adjusted to allow a maximum of 0.5° rotation of the shaft and, at the same time, permit the shaft to slide under it with a minimum of friction.

2-16. MOUNTING PLATE ASSEMBLY. (See figure 2-17.)

2-17. DISASSEMBLY. Except for attaching parts and, as noted below, disassembly will follow the order of the index numbers assigned to the exploded view.

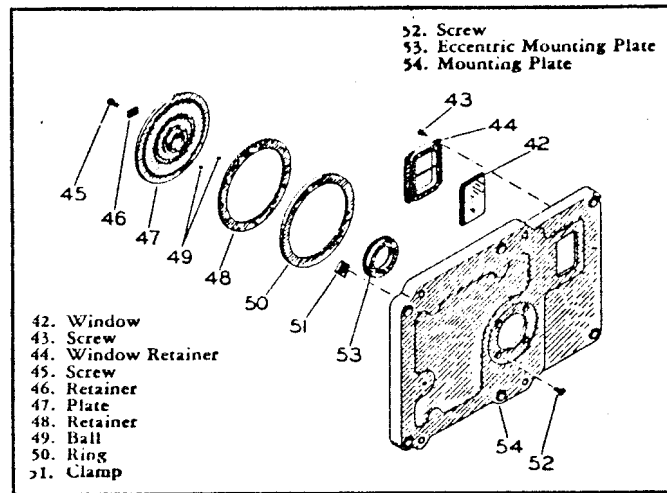

Figure 2-17. Mounting Plate Assembly

a. Before disassembly, scratch a reference mark on the mounting plate (54) in line with the scribed mark on the eccentric mounting plate (53). This mark will be used as an aid in reassembly.

b. When lifting the plate (47) out of the mounting plate (54), make provisions for catching the ball bearings located between the plates.

2-18. ASSEMBLY. (See figure 2-17.)

a. Place the eccentric mounting plate (53) in the recess of the mounting plate with the two spanner wrench holes down, and with the reference marks in alignment. Secure the eccentric in this position with four flat head screws (52) and clamp (51).

b. Turn the plate over and place 27 balls (49) into the recess of the eccentric mounting plate (53). To hold the balls in place apply a few drops of a suitable oil (MIL-L-6085A) to the bearing race.

c. Place the retainer (48) over the large bearing ring (50). Place a ball (49) in each of the holes provided. A few drops of oil (MIL-L-6085A) on the bearing ring is sufficient lubrication.

d. Replace plate (47). It should revolve freely and the balls on the larger circumference should contact both the outer race and the bearing surface of the disk.

e. Secure the bearing plate to the mounting plate with retainers (46) and two screws (45).

Note

The guides are not to hold the bearing plate tight but rather to prevent its falling out of the mounting plate.

f. If the window (42) is loose or a leak is suspected at that point, remove it and spread a moderate amount of cement EC1093 activated with EC1063, on the contacting surfaces. The cement is manufactured by Minnesota Mining Co.

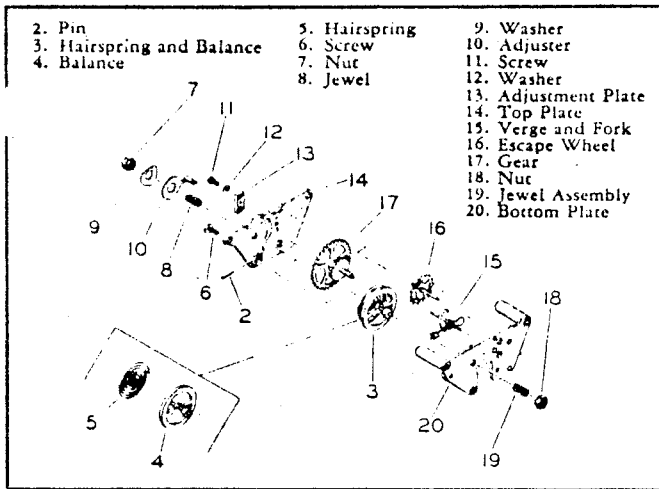

Figure 2-18. Clock Mechanism Assembly

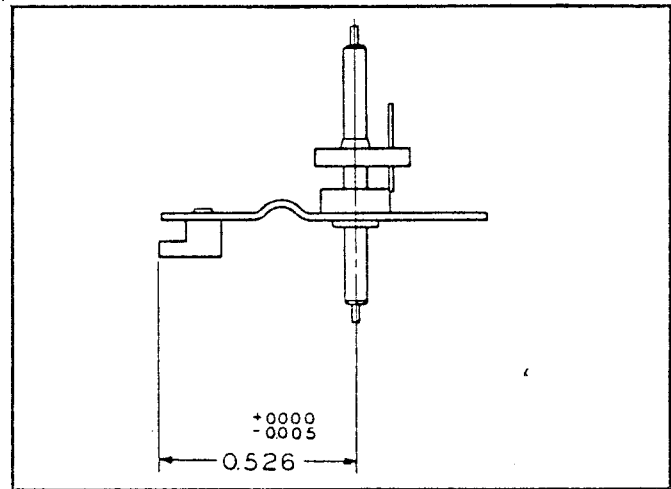

Figure 2-20. Dimension of Verge and Fork

2-19. CLOCK MECHANISM ASSEMBLY. (See figure 2-18.)

2-20. DISASSEMBLY. Except for attaching parts, the disassembly procedures will follow the order of the index numbers assigned to the exploded view.

2-21. REPAIR.

- a. When replacing the hairspring, refer to figure 2-19.
- b. When replacing verge and fork (15) refer to figure 2-20.

2-22. ASSEMBLY OF CLOCK MECHANISM. (See figure 2-18.)

a. Shape and position the hairspring so that the impulse pin of the balance wheel assembly will hold the verge and fork assembly in line with the pivot points of the two assemblies. With the balance wheel assembly at rest, the verge and fork assembly should be equidistant between the fork stop pins of the bottom plate assembly. (See figure 2-21.)

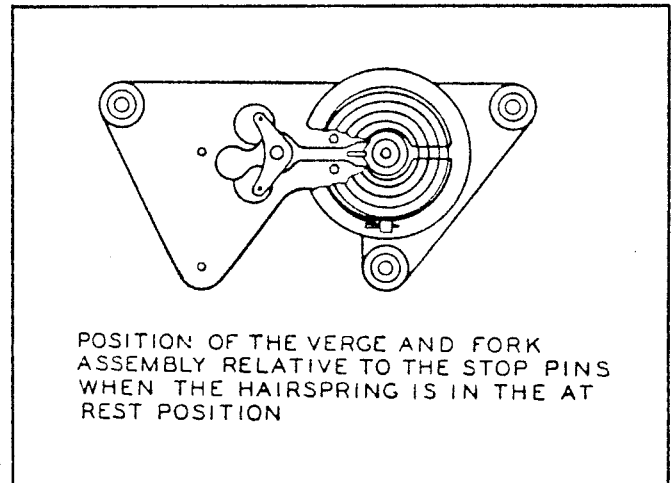

Figure 2-21. Position of Verge and Fork

b. Apply moderate pressure to the gear (17). The clock mechanism should start immediately and have a lively, even beat.

c. It may be necessary to adjust the mesh between the verge and fork (15) and the escapement wheel (16) by moving the adjustable plate (13) on the top plate assembly. If any mesh adjustment is made, be sure the end of the fork does not bottom in the groove of the roller on the hairspring and balance (3). If the beat is uneven, it can be adjusted by repositioning the hairspring.

Note

The pivots of the clock mechanism are lubricated with a very light surface film of oil. (MIL-L-6085A).

2-23. PINION SHAFT AND CLUTCH ASSEMBLY. (See figure 2-22.)

2-24. DISASSEMBLY.

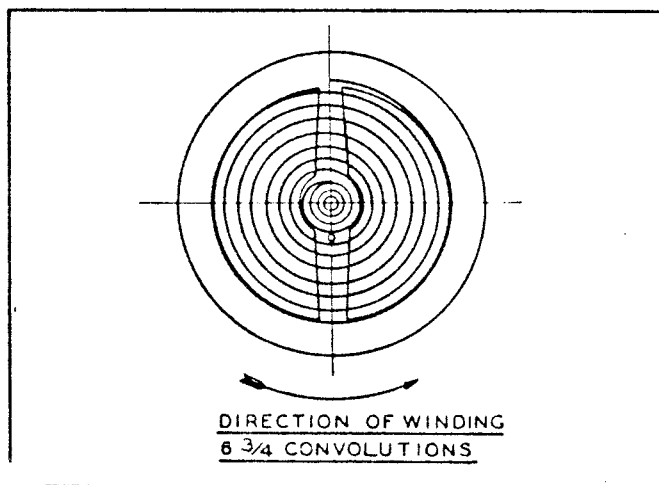

Figure 2-19. Position of Hairspring

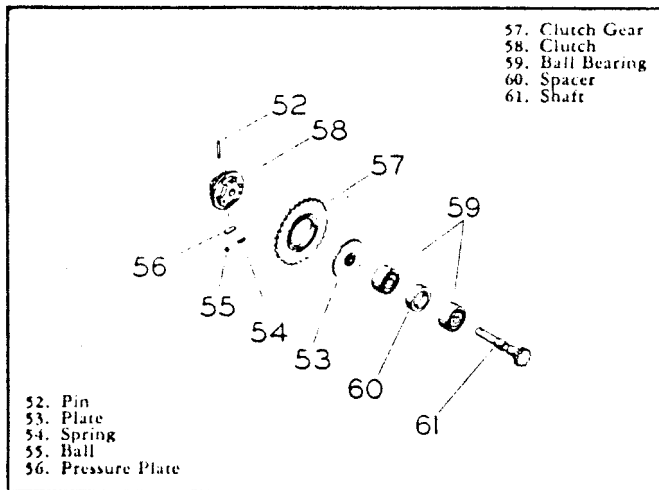

Figure 2-22. Pinion Shaft and Clutch Assembly

a. At the manufacturer's discretion, depending upon the fit of the component parts, a pin (52) may or may not be used on this assembly. Holding the pin end of the assembly on a V-block or across the open jaws of a vise, drive the pin through the shaft.

b. Select a hole in an arbor press having a slightly larger diameter than the ball bearing. Place the assembly in the hole with the plate (53) resting on the table of the arbor press.

c. Apply pressure to the end of the shaft, pushing it out of the clutch assembly.

d. Without disturbing the position of the parts carefully invert the clutch assembly on the arbor press.

CAUTION

Do not handle the assembly by the large clutch gear (57). If this assembly is not disassembled in the proper rotation, loss of the springs (54) or balls (55) may result.

e. Remove the plate (53) and lift the three springs (54), three balls (55) and three pressure plates (56) out of the recesses.

f. Lift the clutch gear (57) off the clutch (58).

g. Select a hole in the arbor press having a slightly larger diameter than the gear on the shaft (61).

h. Place the assembly, with the gear down, into the hole with the ball bearing resting on the table of the arbor press.

i. Apply pressure to the shaft (61) pushing it through the ball bearings (59) and spacer (60).

2-25. ASSEMBLY OF PINION SHAFT AND CLUTCH ASSEMBLY. (See figure 2-22.)

a. Place one ball bearing (59) over a suitable hole on the table of an arbor press. Insert the shaft (61) into the bearing. Apply pressure to the geared end of the shaft pushing it into the bearing.

b. Place the other ball bearing (59) over the hole in the table and place the spacer (60) on top of the bearing.

c. Place the above shaft and bearing into the hole of the second bearing. Place 0.003 inch shim stock between the spacer and the first ball bearing. Apply pressure to the shaft pushing it into the second bearing. Push the bearings home but, as yet, do not remove the shim stock.

d. Place the clutch (58) in a suitable hole in the arbor press with the gear of the assembly resting on the table.

e. Place the clutch gear (57) on the clutch.

f. Into the recesses thus formed, place three pressure plates (56), three balls (55) and three springs (54) in the proper position. (See figure 2-23.)

g. Place one drop of oil (MIL-L-6085A) on each ball.

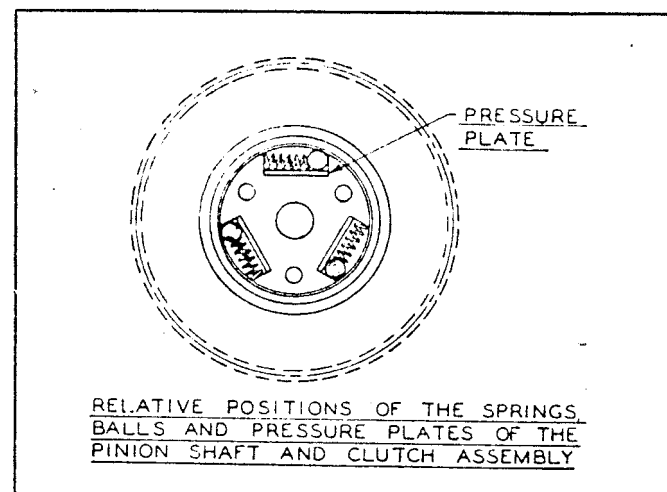

Figure 2-23. Detail of Clutch

h. Place the plate (53) flat side down, on the above assembly.

i. Position the previously assembly shaft and bearings into the hole of the clutch-retaining plate.

j. Carefully apply pressure, pushing the shaft through the retaining plate and the clutch assembly, until the raised portion of the retaining plate is tight against the inner race of the ball bearing.

k. Remove the shim stock. The spacer (60) between the ball bearings should fall free and the shaft should rotate without binding or roughness. Holding the assembly vertical, with the geared end of the shaft down, rotation of the clutch gear (57) in a counterclockwise direction should cause the clutch to slip allowing the shaft to remain stationary.

l. The force required to push the shaft through the clutch determines the necessity for the pin (52).

m. If a pin is necessary, drill a hole with a No. 65

Paragraphs 2-25 to 2-28

(0.055) drill through the shaft and clutch. Taper the hole with a reamer. Insert the taper pin and file the ends flush.

2-26. AVERAGER CONTROL UNIT. (See figure 2-24.)

2-27. DISASSEMBLY. Except for attaching parts the disassembly procedures will follow the order of the index numbers assigned to the exploded view.

2-28. ASSEMBLY OF AVERAGER CONTROL UNIT. The replacement of any of several parts may affect the operation of the remaining parts and, therefore, they must be fitted and adjusted as they are being assembled. The parts are not interchangeable without alterations.

a. Place the stop post mount (36) on the control mount (37) and secure it with two fillister head screws (35).

b. Turn in one screw (34) until it touches the stop

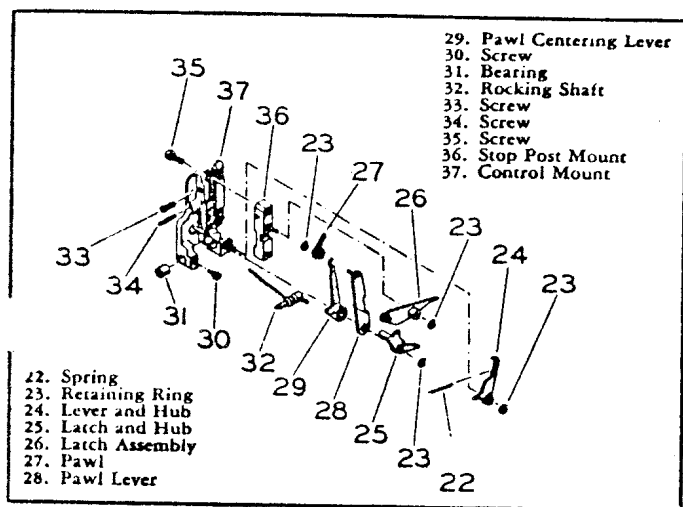

Figure 2-24. Averager Control Unit

mount assembly. Insert another screw (33) through the clearance hole in the control assembly and turn it into the stop post mount assembly.

c. Allow approximately 0.005 inch end play for the rocking shaft (32).

d. Place the above assembly in position on the mechanism frame assembly (56, figure 2-14) and secure it with two anchor screws (43, figure 2-14).

Note

The holes in the mechanism frame assembly are large clearance holes for the screws (35).

The screws should be positioned approximately in the center of these holes to allow for adjustments. The reassembly of the averager control unit must be performed while it is mounted on the mechanism frame.

e. Place the pawl (27), milled surface down, on the end of the pawl lever (28) and secure the parts with a retaining ring (23).

Note

The pawl must rotate freely on the stud with a minimum of clearance.

f. Insert the pawl lever (28), with the attached pawl (27) into the hole of the pawl centering lever (29) so that the hooked end of the pawl centering lever will mate with the pawl (27).

Note

The pawl lever (28) and the pawl centering lever (29) must move freely with a minimum of clearance.

g. Place the above assembly on the post which is located just above the rocking shaft (32). Figure 2-25 shows the relationship of the actuating parts of the control unit.

h. Lubricate the shaft of the spring assembly (33, fig-

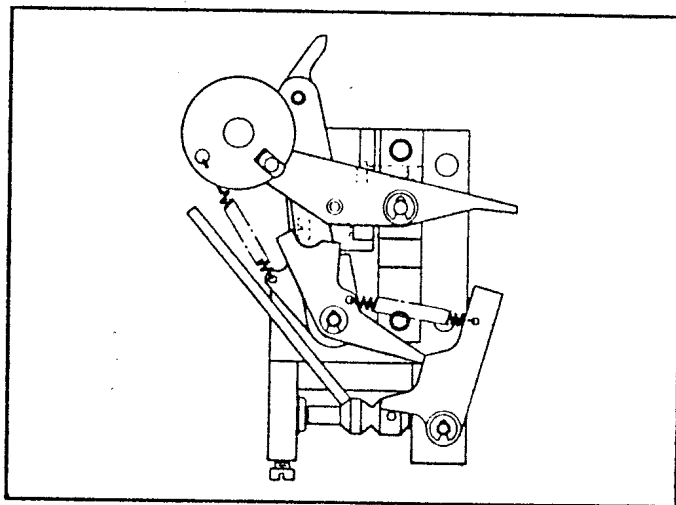

Figure 2-25. Detail—Control Unit

ure 2-14) with a suitable oil (MIL-L-6085A) and insert it into the casting.

i. Place the fork assembly (32, figure 2-14) on the other end of the spring assembly and secure it with a taper pin.

j. (Figure 2-24) Place the latch assembly (26) on the shaft of the stop post mount (36) with the filed pin down and, with the stud positioned in the slot of the sweep fork assembly. Secure with a retaining ring (23).

k. Connect the spring (41, figure 2-14) between the sweep fork assembly and the pawl centering lever (29, figure 2-24).

l. Place the latch and hub (25) on the shaft which is located above the rocking shaft (32) with the tab between the spring and the pawl lever (28). Secure the parts on the shaft with a retaining ring.

m. Place the lever and hub (24), with the tab down, on the stud adjacent to the pivot point of the rocking shaft. Secure the part on the shaft with a retaining ring.

n. Connect the spring (22) between the lever and hub (24) and the latch and hub (25). This spring action should cause the shutter actuating lever and hub assembly to press against the short lever of the rocking shaft assembly. See paragraph 2-38 for the adjustment of the control unit.

2-29. BALL CARRIAGE ASSEMBLY. Disassembly of this unit is not recommended as the rollers used on this assembly are of different tolerances and are not interchangeable. However, the assembly may be cleaned in Xylene (Specification TT-X-916) upon overhaul, but if any parts appear to be damaged or worn the entire assembly must be replaced. The surface of each roller should be smooth and it should rotate on its shaft freely without sticking. The shafts should be tight in the casing and they should not be bent in any manner. The large bearing hole should be cleaned with a wooden dowel immersed in Xylene and then rotated in the bearing. The gear rack should be well secured to the frame and tight against the casting boss.

CAUTION

Do not use an abrasive to clean the bearing as the tolerances are held close and the use of an abrasive may enlarge the hole.

2-30. AVERAGER COVER ASSEMBLY. (See figure 2-26.)

2-31. DISASSEMBLY. Disassembly will follow the order of the index numbers assigned to the exploded view.

2-32. ASSEMBLY OF THE AVERAGER COVER ASSEMBLY. Except as noted below, assembly will follow the reverse order of the index numbers assigned to the exploded view.

a. When replacing the averager actuating lever (9), allow for 5/16 inch travel of the operating lever (12).

b. Position the rewind lever (2) on the shaft of the rewind shaft (7) so that the lug on the disk will engage the cutout in the disk of the coupling plate (47, figure 2-27) on the plate assembly.

2-33. LUBRICATION.

2-34. GENERAL. Oil must be applied sparingly. Only those parts listed below should be lubricated. (Specification MIL-L-6085A.)

- Ball bearings of yoke and index assembly.
- Ball bearings of clutch assembly.
- Shaft of spring assembly (33, figure 2-14).
- Balls of mounting plate assembly (49, figure 2-17).
- Pivots of clock mechanism.

Note

Do not lubricate any part of the index assembly (8, figure 2-15).

2-35. REASSEMBLY.

2-36. ASSEMBLY OF THE AVERAGER. (See figure 2-14.)

a. Insert the idler gear and shaft (54) in the bushings of the mechanism frame and secure it with a thrust washer (53) and retaining ring (52). The gear and shaft should revolve freely in the bushings.

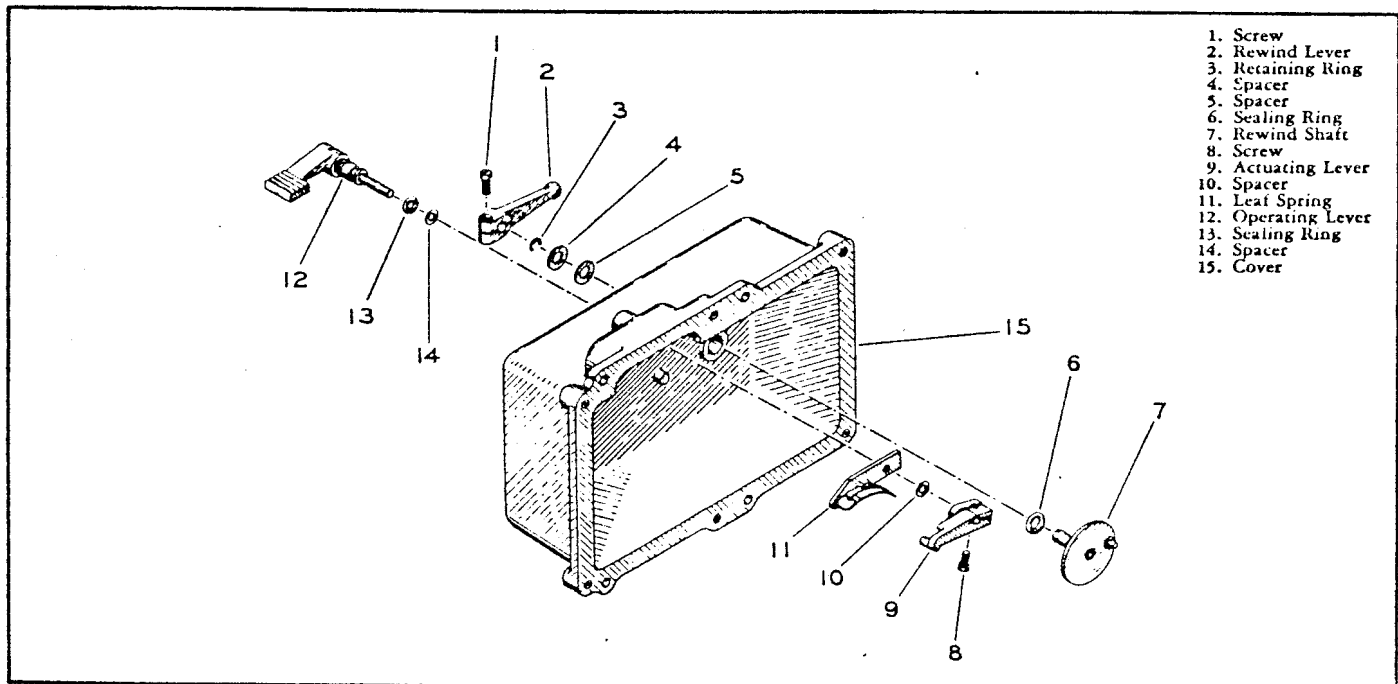

Figure 2-26. Averager Cover Assembly

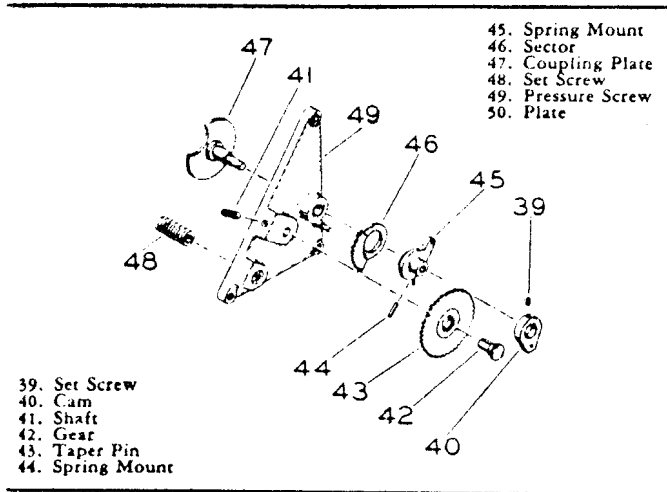

Figure 2-27. Plate Assembly

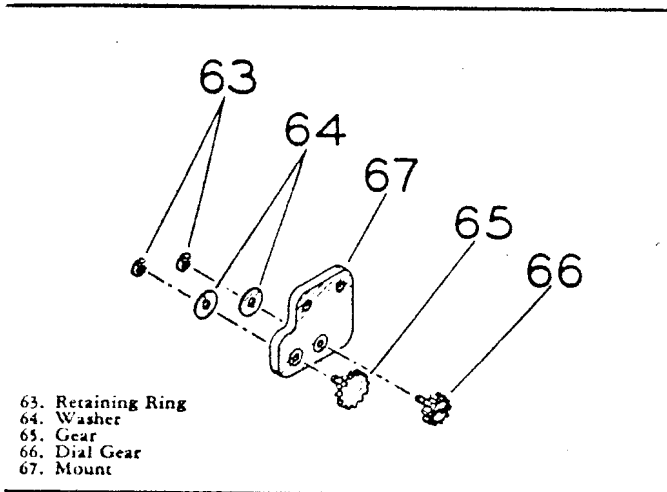

Figure 2-28. Dial Plate and Gear Assembly

b. Insert the shaft (51) into the casting and secure it with set screw (50). Place a washer (49) and the gear assembly (48) on the shaft and secure them with a thrust washer (47) and a retaining ring (46). Insert the shaft and clutch (45) into the casting. Temporarily attach the plate (4) to the casting with three screws (5). Position the height of the pinion shaft and clutch assembly relative to the meshing gear on the triangular plate assembly. Secure the clutch in this position with the set screw (44). Then remove the triangular plate assembly.

c. Place the control unit (42) over its pivot pin in the mechanism frame and secure it with two anchor screws (43).

Note

If a lever of the control unit (42) has been replaced or a new control unit installed, it cannot be installed as a unit. It must be built up piece by piece and adjusted accordingly. For the adjustment procedures, see paragraph 2-38.

d. If the original frame assembly (56) and the ball carriage (40) are used, place one guide (39) (located near center of casting) on its locating pins and secure with four screws (38). Place the ball carriage (40) on this guide and install the other guide (39) over its locating pin and secure with four screws (38). Mount the stop plate (37) on the ball carriage assembly with three fillister head screws (36).

e. However, if either the frame assembly (56), or the ball carriage assemblies (40) have been replaced, the following procedure must be followed.

f. Assemble the guides (39) and the ball carriage (40) to the mechanism frame as explained above. Position the one guide (39) (located near center of casting) so when the ball carriage is held tightly against it and moved the length of the guide the mesh between the idler gear and shaft (54) and the gear rack on the ball carriage will be close and even. A rough mesh or a sloppy mesh should not be tolerated.

g. After the mesh has been properly adjusted, move the other guide (39) into position allowing the ball carriage (40) 0.002 inch side play at any point. Tighten the guide mounting screws (38). With the casting face up on the bench alternately lift each end of the casting. The weight of the ball carriage assembly should be sufficient to overcome inertia when the end is tilted approximately 15 degrees. The carriage should travel back and forth without binding or hesitation at any point. When the above conditions have been satisfied drill and ream a hole $0.0620 \text{ in. } \begin{matrix} +0.0000 \\ -0.0005 \end{matrix} \times 0.218 \text{ in.}$ deep through the carriage guide and into the mechanism frame in four places. Blow out the metal chips and press a locating pin in each of the holes. The end of the pin should be flush with the surface of the carriage guides.

h. Remove and clean the upper and lower carriage guides and the ball carriage assembly. After cleaning, reassemble the parts to the casting.

i. Secure the plunger spring (35) to the mechanism frame with two screws (34). If necessary, bend the spring slightly to increase the tension against the casting boss.

j. Insert the shaft of the spring assembly (33) through the hole in the mechanism frame. Place the fork assembly (32) over the end of the shaft and insert the taper pin (31).

Note

The procedure to adjust the position of the sweep wire spring assembly which starts and stops the action of the clock mechanism will be found in paragraph 2-38.

k. Insert the mounting pins of the yoke and index (30) into the hole in the mechanism frame and secure the parts with a retaining ring (28) and spacer (29).

l. Place the lever (27) on the pivot pin of the yoke and index assembly and secure it with a thrust washer

(26) and a retaining ring (25). Attach the spring (24) from the end of this lever to the spring hook (55).

m. Install the plunger (19) into the mechanism frame. As the plunger is inserted move the pawl out of its path, otherwise it or other parts may be damaged.

Note

At this stage of the assembly, the control unit must be adjusted. See paragraph 2-38 for the adjustment procedure.

n. Attach the clock mechanism (21) to the mechanism frame with three screws (22) and lockwashers (23).

o. Attach the two power springs (20) to the ball carriage (40) and the anchor screws (43).

p. Attach the plate and gear (18) to the mechanism frame with two shoulder screws (17). Position the holes in the dial gear assembly so that when the ball carriage assembly is at either end of its travel, the holes of the dial gear will be parallel to the carriage guide. Attach the averager dial (16) to the dial gear with two screws (15) so that the zero graduation is next to the index markers.

q. Drop two clean balls (13) into the bushing of the ball carriage assembly. Drop a small drop of oil (MIL-L-6085A) on each ball.

r. Insert the push rod (14) into the hole of the mounting plate (9).

s. Place the completed mounting plate assembly on the mechanism frame with the locating pins of the mounting plate inserted into their respective holes in the casting.

t. Secure the parts with four screws (10) and three lockwashers (11).

u. Attach the spring (6) to the spring hook (55) and the hole in the spring mounting piece assembly of the plate assembly. Place the compression spring (7) and the pressure contact (8) into the pressure screw of the plate assembly.

v. With the ball carriage assembly at the unwound position, mount the plate (4) to the mechanism frame with three screws (5).

Note

The sector gear of the plate assembly should be engaged in such a position so as to fully wind the mechanism when the sector shaft is rotated, and also release the index disks to permit their return to the zero position. See paragraph 2-39 for the adjustment procedure.

w. Turn down the pressure contact screw located in the plate (4) sufficiently to assure contact of the ball (13) in the ball carriage (40) with the bearing plate of the mounting plate (9). See paragraph 2-40 for the adjustment procedure.

Note

At this stage, the averager must be adjusted to operate within specified tolerances. (See paragraphs 2-38 through 2-44 for the various adjustment procedures.)

2-37. AVERAGER ADJUSTMENTS.

2-38. CONTROL UNIT (See figure 2-29). Before this unit can be successfully adjusted, the averager must be assembled up to and including paragraph 2-36m of the reassembly procedure.

a. Move the ball carriage (1) to the wound position, the ball carriage stop latch assembly (2) will position itself behind the stop of the plate assembly (3). Hold the ball carriage at the extent of its travel and observe the clearance between the end of the ball carriage stop latch assembly and the edge of the stop. As a preliminary setting this distance should be approximately 0.015 inch. If such is not the case remove the plunger and loosen the two holding screws (4) which are located on the underside of the casting and reposition the adjustment screws (5) and (6) until the condition is satisfied. Tighten the holding screws (4).

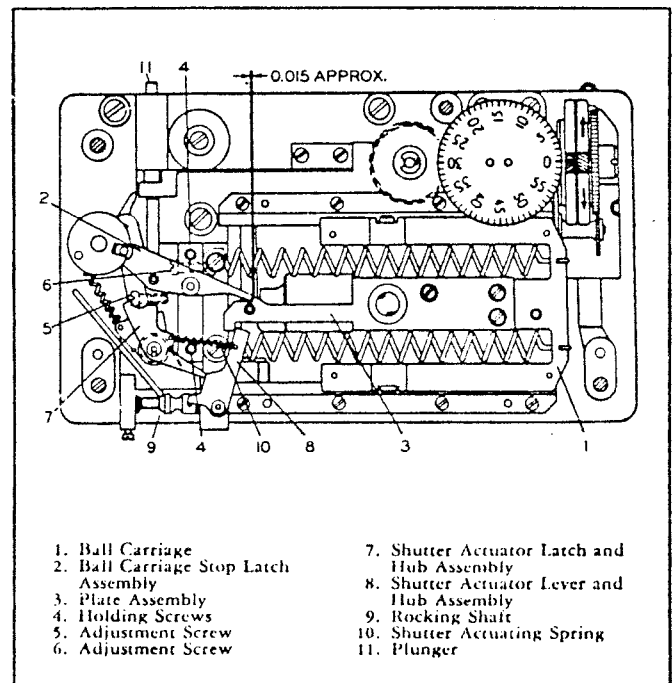

Figure 2-29. Operation of Control Unit

b. Depress the plunger (11) to the extent of its travel. With the averager in the wound position, the shoulder on the plunger should clear the pawl on the control unit and should contact the pawl only after the narrow end of the ball carriage stop latch assembly (2) has cleared the raised portion of the ball carriage stop plate. This condition is attained by adjustment of the adjustment screws (5 and 6). When making this adjust-

Paragraphs 2-38 to 2-39

ment, be careful to maintain the setting described in paragraph 2-38a.

c. Depress the plunger (11) to the extent of its travel and move the ball carriage along the rails until the pin of the plate assembly (3) strikes the shutter actuator latch and hub assembly (7) causing it to trip from its position on the shutter actuator lever and hub assembly (8). This movement will actuate the rocking shaft (9) which in turn will operate the shutter mechanism in the sextant. In the event that the latch and hub assembly (7) does not trip, remove the assembly and carefully file the edge in the area as shown in figure 2-30, view A.

d. Unhook the shutter actuating spring (10) and connect the two power springs between the ball carriage and the anchor posts. Then replace the shutter actuating spring.

e. Mount the clock mechanism assembly to the casting and secure it with three screws. Check the end play of the balance wheel; if insufficient, reposition the jewel assemblies. Check the mesh of the gears between the clock mechanism and the clutch assembly. If necessary, shift the clock mechanism slightly until there is no binding of gears. Continue assembly described in paragraph 2-36.

f. Fully wind the mechanism by rotating the sector shaft on the plate (4, figure 2-14) to the extent of its travel and releasing it. Observe the position of the

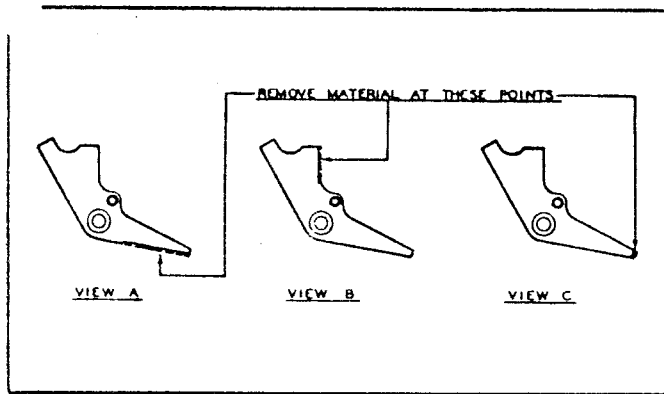

Figure 2-30. Latch and Hub Assembly

sweep wires which start and stop the action of the clock mechanism. The sweep wires must clear the balance wheel as shown in figure 2-31, view A.

g. Start the mechanism in operation by depressing the plunger and releasing it. This action will cause the spring assembly to change position and, in doing so, the looped sweep wire will contact the balance wheel as it passes and gives it a starting impulse as shown in figure 2-31, view B.

h. When the mechanism is stopped either manually (by depressing the plunger) or automatically (by the action of the control unit), the spring assembly will assume a position to contact the balance wheel and arrest its action as shown in figure 2-31, view C. The

sweep wires of the spring assembly must be adjusted to satisfy the three positions.

i. (See figure 2-29.) Move the ball carriage assembly to the unwound position. Revolve the rocking shaft (9)

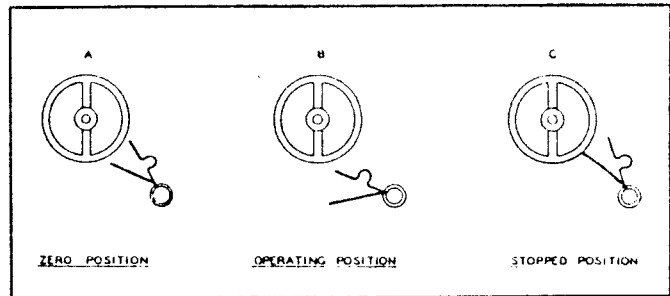

Figure 2-31. Position of Sweep Wires

until the long lever touches the casting. The short lever of the rocking shaft should move the lever and hub assembly (8) permitting the latch and hub assembly (7) to assume its starting position. If such is not the case the position of the short arm of the rocking shaft (9) must be changed to increase the travel of the lever and hub assembly (8).

j. Move the ball carriage assembly to the wound position and then release it. The power springs will move the ball carriage along the rails until it is restrained by the end of the ball carriage stop latch assembly (2). At this point the clock mechanism will cease to function. This is the tentative zero position of the mechanism; the actual zero position will be determined by the adjustments in paragraph 2-44.

2-39. INDEX RELEASE. (See figure 2-32.) When the sector shaft (1) is rotated counterclockwise, the collar (2) must contact the index release lever (3) which will release the index disks permitting them to return to the zero position. Excessive linear movement of the index shaft will cause the index disks to strike the window or the reduction gear assembly which could damage the

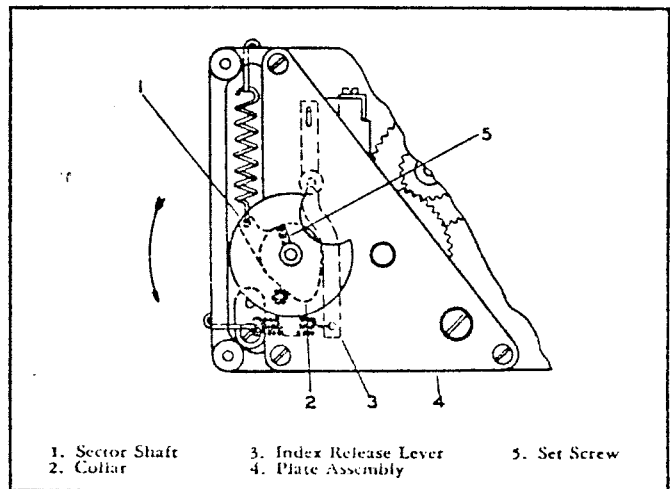

Figure 2-32. Index Release Adjustment

index assembly. It may be necessary to remove the plate assembly (4) several times to place the collar in the proper position so as to contact the index release lever almost at the end of its travel. This is done by loosening the set screw (5) and rotating the collar to its correct position. However, if the plate assembly is removed, it will be necessary to run the clock mechanism for its full one-minute period so that it is unwound before replacing the plate assembly.

2-40. PRESSURE CONTACT SCREW. (See figure 2-14.) The pressure contact may be adjusted in the following manner. Place the averager on the bench with the triangular plate assembly (4) facing up. Turn the pressure screw in a counterclockwise direction and, at the same time, alternately lift up and release the yoke and index (30) until it has free movement. Then turn the pressure screw clockwise and, at the same time, alternately lift up and release the yoke and index assembly until the free movement has been taken up by the position of the screw. Permit the mechanism to operate until the time dial indicates 15. Rotate the bearing plate located in the mounting plate (9) with a suitable tool and observe the movement of the friction disk gear assemblies. If the assemblies show any indication of slipping, increase the tension on the pressure contact screw until there is no apparent slippage while rotating the bearing plate. At this point, further increase the tension by one full turn. Excessive pressures will not permit the knob on the sextant to operate freely and smoothly. It is, therefore, important, that the tension is correctly adjusted. After adjustment cover the head of the screw with Minnesota Mining and Manufacturing Co.'s E.C. 801 Cement.

2-41. SPRING TENSIONS. (See figure 2-14.)

a. Tension of the spring (6) must be sufficient to return the parts attached to the shaft of the plate assembly, to its starting position after the mechanism has been wound.

b. Tension of the spring (24) must be sufficient to prevent slippage of the index disks. If a new spring is being installed, apply tension by changing the position of the spring hook (55) in the frame assembly (56) to its maximum position so that the spring is fully loaded.

2-42. TIMING THE AVERAGER. (See figure 2-33.) The averager must be operated for a maximum time interval of 60 seconds and must be timed against a master stop watch, electric timer or equivalent. Conduct the test as follows:

a. Rotate the sector shaft (1) to wind the averager and then release it to be assured of maximum operation. The mechanism should operate for approximately 3 seconds before it is automatically stopped. At this point the time dial (2) should indicate zero.

b. Simultaneously depress and release the averager operating shaft (3) and the master stop watch.

c. Stop the master watch when the shutter actuating

push rod (4) "pops" out. The time dial should indicate 30 seconds. The difference between the master watch and twice the averager time dial reading must not exceed 1 second.

Note

The averager time dial indicates half the time of observation in seconds.

2-43. ADJUSTMENT OF CLOCK MECHANISM. The clock is so adjusted to allow the ball carriage assembly to travel between the stops in 60 seconds ± 2 seconds. Lengthen or shorten the effective length of the hair-spring to accomplish this adjustment.

2-44. FINDING THE CENTER OF ROTATION OF THE BEARING PLATE AS INDICATED ON THE INDEX DISKS. (See figure 2-33.)

a. Each averager has certain inherent errors which

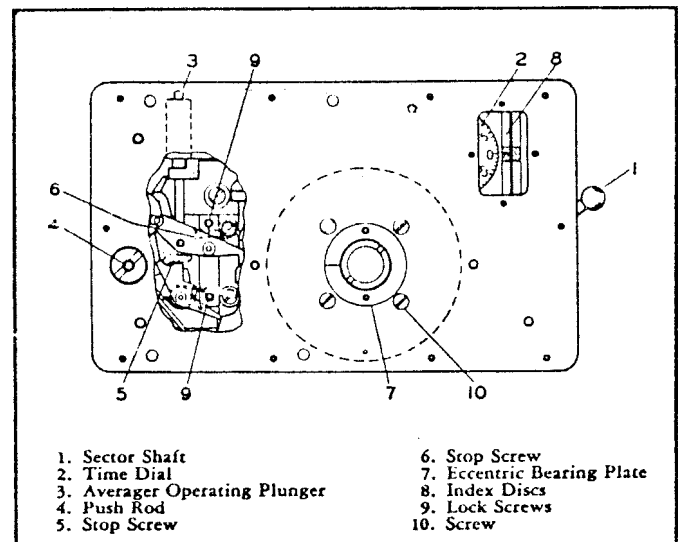

Figure 2-33. Averager Adjustments

must be adjusted to within its operating tolerances. The ball carriage of the averager operates between two rails, allowing the carriage very little side play. The carriage travel is governed by two adjustable stop screws (5 and 6) which are mounted on the control unit. The stops are so adjusted that when the averager is fully wound it will be stopped by the control unit. At this position the point of contact of the ball in the carriage will be on the vertical centerline of the bearing plate of the mounting plate assembly. Due to the allowable side play of the ball carriage and the play in the radial bearing of the bearing plate, an eccentric adjustment (7) located in the mounting plate assembly is used to position the ball on the horizontal center line. By adjusting the carriage stops and the position of the eccentric, the errors of the averager may be controlled.

b. Using a suitable tool rotate the bearing plate and observe the movement of the index disks (8). The reference line on the index assembly should not move more than 0.010 inch in either direction from the zero reference line on the window when the plate is rotated

Paragraphs 2-44 to 2-45

5 revolutions. If the reference line moves down when the plate is rotated clockwise, loosen the two lock screws (8) located on the underside which secure the plate and two adjustable screws (5 and 6). Turn out screw (5) the required amount and turn in screw (6). This adjustment will permit the ball carriage further travel to position the ball over the vertical centerline of the bearing plate.

c. If the reference line on the index assembly moves up when the plate is rotated clockwise, loosen the lock screws (9), turn out screw (6) the required amount, then turn in screw (5). This adjustment will shorten the travel of the ball carriage to position the ball over the vertical centerline of the bearing plate.

d. If when the plate is rotated in one direction the reference line of the index assembly should move up or down, and when the plate is rotated in the opposite direction, the reference line of the assembly remains stationary, it is an indication that an eccentric adjustment must be made. By repositioning the eccentric (7) the point of contact of the ball in the carriage is brought closer to the horizontal centerline of the disk. The eccentric may be adjusted by loosening the four screws (10) that secure it, placing a spanner wrench (TE5161) in the two holes provided, and turning it. Trial and error is the only recommended method for the eccentric adjustment.

e. Alternate between the two adjustments until the maximum movement of the reference line on the index assembly is not more than 0.010 inch in either direction from the zero reference line on the window when the plate is rotated 5 revolutions. A perfectly adjusted instrument will show no movement since the ball in the carriage will be at the center of rotation of the disk.

Note

Before each adjustment to either the adjusting screw or to the eccentric, depress the averager operating plunger (3) and allow the instrument to operate for a few seconds. Then, after an adjustment has been made, rewind the mechanism and continue the test.

f. If, when the above conditions are satisfied, the zero indication of the time dial is not coincident with the reference line in the window, reposition the dial by loosening the dial screws. If there is insufficient adjustment in the dial holes, remove the dial plate and advance the dial gear one tooth as conditions demand.

g. Replace the disassembled parts and fully wind the mechanism by depressing the rewind lever and then releasing it. The mechanism should run until the zero on the time dial is coincident with the reference line in the window and at which time the mechanism will stop. To start the mechanism in motion again, depress and release the averager operating plunger. Allow the ball carriage to operate to the extent of its travel (one minute). As the time dial approaches the 30 graduation observe at what point, as indicated on the dial, the

shutter actuating push rod (4) is extended through the mounting plate. This action should occur approximately 1 graduation from the 30 graduation. If the action occurs too soon, too late, or not at all, disassemble the averager to the point where the control unit is accessible.

h. If the action occurs too soon remove sufficient material from the area as shown in figure 2-30, view B.

i. If the action occurs too late, or not at all, remove sufficient material from the area as shown in figure 2-30, view C.

j. Trial and error is the only recommended procedure when removing material from the various levers.

k. After the control unit has been adjusted and performs satisfactorily, retest the averager.

2-45. FINAL CALIBRATION OF AVERAGER.

a. To complete the final calibration of the averager, the fixture (TE5163) must be attached to the averager.

b. Clamp the averager to the fixture. Rotate the knob until it hits the stop pin, and again note the indication on the counter.

c. Rotate the knob in the opposite direction until it hits the stop pin, and again note the indication on the counter.

d. The two indications are the extremes, and by dividing the difference and adding it to the smaller angle, the mean is obtained.

e. Rotate the knob until the counter indicates the mean. This is the starting position.

f. Start the averager operating by depressing and releasing the averager operating lever. While it is running, rotate the knob back and forth between the stops in a regular rhythm at a frequency of about 10 to 12 cycles per 30 seconds time interval (15 seconds time interval indicated on the half time dial). After a 30-second interval (15 seconds indicated), stop the averager mechanism by depressing and releasing the averager operating lever and return the reference line of the index assembly to the zero reference line located on the window by rotating the altitude knob. Record the indication on the counter. The difference between this reading and the mean reading observed at the start of the test is the error at this point. The error should not exceed ± 5 minutes of arc.

Note

Do not rewind the averager after the 15-second and 30-second indicated readings are recorded. The initial winding of the mechanism should be used during this check.

g. Continue the test in the above manner and record the errors at the 30-second (indicated) time interval. Errors should not exceed ± 3 minutes of arc at the 30-second time (indicated) test point.

h. Rewind the averager and repeat the test with the initial motion in the opposite direction to that of the initial motion of the previous test.

i A clearer description may be obtained through the following example.

Example:

Starting angle 28° 00' (mean).

Rotate the altitude knob with the initial movement counterclockwise, back and forth between the stops, for 10 cycles and stop the rotation and the averager at 15 seconds (indicated) — read the altitude counter. For this example we will say it reads 28° 4' or has an error of 4' of arc at 15 seconds time (indicated). We know from experience such a large error at 15 seconds will cause greater errors at the 30-second interval. We will attempt to reduce the error in the following manner. Remove the averager from the fixture and loosen the 4 screws holding the eccentric. Place a spanner wrench (TE-5161) in the two holes of the eccentric and move the wrench in one direction, approximately 1/32 inch as measured on the periphery of the eccentric. Tighten the 4 holding screws and attach the averager to the fixture. Retest will show if the eccentric was moved in the right direction. If the errors have increased, remove the mechanism from the fixture and move the eccentric in the opposite direction.

Rewind the instrument and repeat the test.

Starting angle 28° 00'.

Initial Movement CW			Initial Movement CCW		
Indicated		Errors	Indicated		Errors
15	28°03'	+03'	15	28°00'	0
30	28°02'	+02'	30	27°59'	-01'

j. Since the above errors are within the allowable tolerances, the averager may be considered properly adjusted.

k. Rewind the averager. Remove the stop pin and rotate the knob clockwise, then counterclockwise and observe the movement, if any, of the index assembly. This movement should not exceed 0.010 inch through 10 degrees of reading. Adjust the stop screws, as explained previously (see paragraph 2-38), to correct excessive movement. These adjustments are usually minute. The zero on the time dial may move off the zero reference line on the window due to these adjustments. If that is so, remove the mounting plate, loosen the dial screws and reposition the dial.

2-46. DISASSEMBLY.

2-47. DISASSEMBLY OF THE SEXTANT. (See fig-

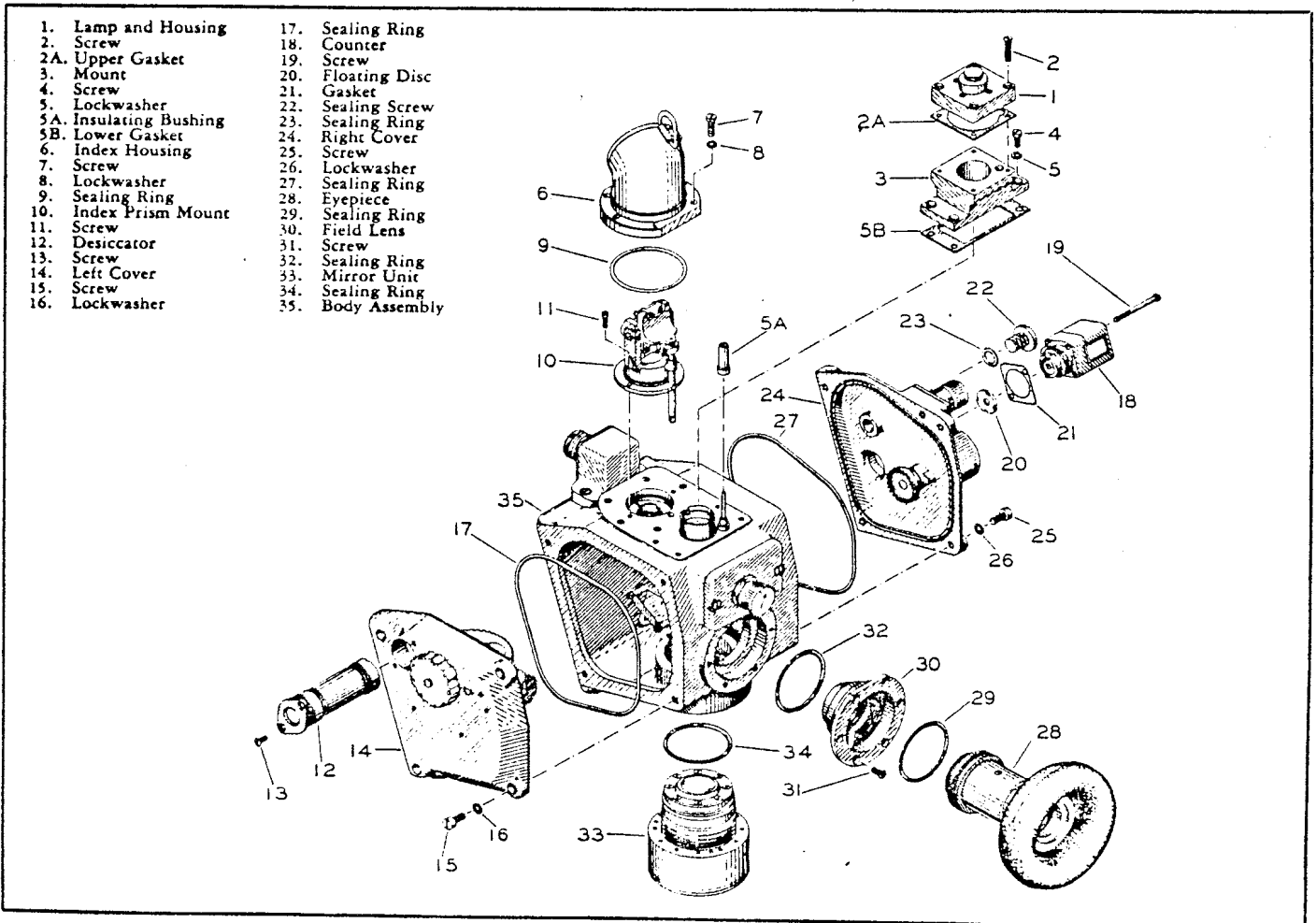

Figure 2-34. Sextant Less Averager

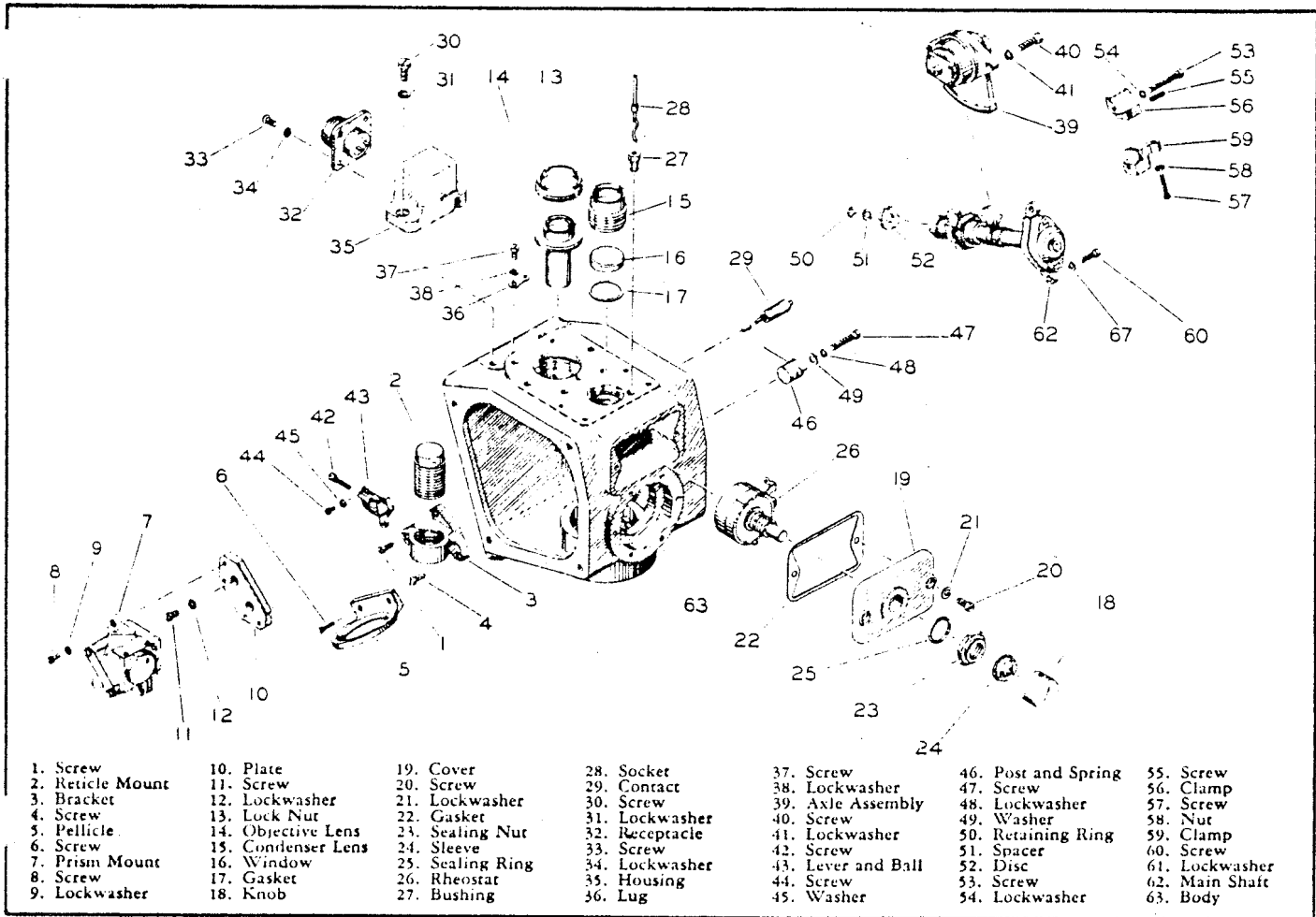

Figure 2-35. Sextant Body

ure 2-34.) Except for attaching parts the disassembly procedures will follow the order of the index numbers assigned to the exploded view.

CAUTION

If care is not exercised during the removal of the left cover assembly, the filter assembly may strike the thin membrane of the pellicle and damage it, necessitating replacement.

CAUTION

A floating disk which is used between the two couplings of the counter and main shaft assemblies may or may not fall out of the assembly when the right cover is removed. In any event the disk must be located and kept with the right cover assembly.

2-48. DISASSEMBLY OF SEXTANT BODY. (See figure 2-35.) Except for attaching parts the disassembly procedures will follow the order of the index numbers assigned to the exploded views.

a. The fixed prism assembly has been adjusted and its setting in the sextant body should not be disturbed unless absolutely necessary.

CAUTION

Exercise extreme care while handling the pellicle (5). Do not touch the membrane as to do so will damage it, necessitating replacement.

b. If it can be avoided do not remove the lever and ball (43) from the axle assembly (39) as to do so will unnecessarily upset the calibration of the sextant.

2-49. CLEANING.

2-50. GENERAL. The lenses and prisms of the sextant have had their light-transmitting surfaces treated with magnesium fluoride to improve the quality of the optical images by reducing reflections and thereby increasing transmission through the optical elements. The recommended procedure for the handling and cleaning of lenses should be adhered to as closely as possible. When handling the optical units, the lenses should always be held by their edges and prisms by the blackened sur-

faces, if possible, as finger marks will stain optical glass. When lenses or prisms are removed from their mounts, they should always be placed on a soft cloth to prevent damage.

2-51. LENSES AND PRISMS. Lens and prism surfaces should be cleaned as follows:

a. Using a vacuum hose, hand blower or camel's hair brush, remove the dust and grit particles.

b. To remove small particles of dust or finger marks, breathe on the lens or prism surface, and then, using a circular motion, wipe the surface with lens tissue or a soft cotton cloth.

CAUTION

Always dust or blow off the lens or prism before wiping the lens, as dust and grit will scratch the surface of the glass and impair the optical quality.

c. If it is necessary to wash the lens or prism, a soap solution or organic solvent such as acetone or grain alcohol may be used.

d. After washing the lens or prism, it should be dried with lens tissue or a soft cotton cloth.

Note

If a component was completely disassembled, all parts (sextant body, optical tubes, lock rings, eyepiece barrel), that are directly related to the optical path or the support of the various lenses and prisms are to be washed with mild, white, bar soap and water to remove all foreign materials. Rinse the parts in clean water and bake dry in an oven 200°C (392°F) for one and one-half hours.

2-52. PELLICLE. To remove dust or lint particles from the thin membrane, a small camel hair brush having long, soft hairs is recommended. If in the opinion of the operator, damage may occur as a result of an attempted removal of certain stubborn particles, it is best that the particles remain rather than risk the damage.

2-53. INSPECTION.

2-54. GENERAL.

- Inspect all leads for insulation breaks.
- All lenses and prisms are to be clean and their magnesium fluoride coating in good condition.
- Pellicle to be free of punctures, stress waves, etc.
- All screws to be reasonably tight.
- Rubber sealing gaskets to be in good condition.
- Adjustment knob to rotate without roughness or binding between -10° and $+92^{\circ}$ as indicated on the altitude counter.
- Silica gel crystals to be dry (blue). If the silica gel crystals are light pink in color they should be replaced.

2-55. REPAIR OR REPLACEMENT.

2-56. DISASSEMBLY OF THE MIRROR UNIT. (See figure 2-36.) Except for attaching parts, disassembly follows the order of the index numbers assigned to the exploded view.

Note

The horizon lens is cemented into the housing. Do not remove unless lens is damaged and replacement is required.

2-57. ASSEMBLY OF THE MIRROR UNIT. Assembly follows the reverse order of the index numbers assigned to the exploded view except for attaching parts. Note procedure below.

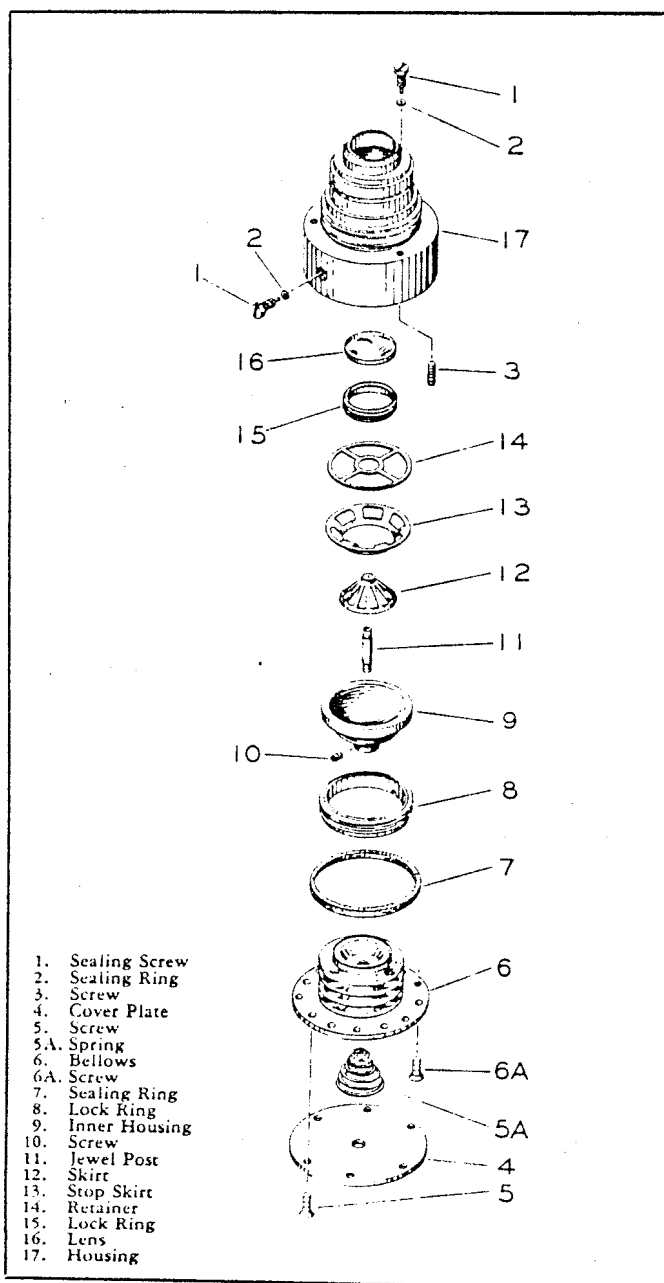

Figure 2-36. Mirror Unit

Note

When replacing cemented lenses first scrape the mounting part clean of cement and wash as per paragraph 2-51. Insert the new lens in the mount and secure with the retaining ring. Using an all-metal syringe and a large gauge needle, insert cement through appropriate hole. Make sure that the cement flows all the way around the groove. Use a dental mirror to check the flow of the cement. The cement will be prepared as follows: mix seven parts by weight of Minnesota Mining and Manufacturing Company's 3M sealer formula EC-1093 to one part of non solvent accelerator EC-1063. This sealer hardens within two hours after mixing. Mix only as much as is needed and use immediately. Be careful not to get the sealer on the lens surface. Wipe the outside surface of the mount clean of excess sealer with cloth moistened with Toluene (Specification JAN-T-171 Amend. No. 2). Bake the assembly in an oven at +70°C (+160°F) for four hours and allow to cool in air.

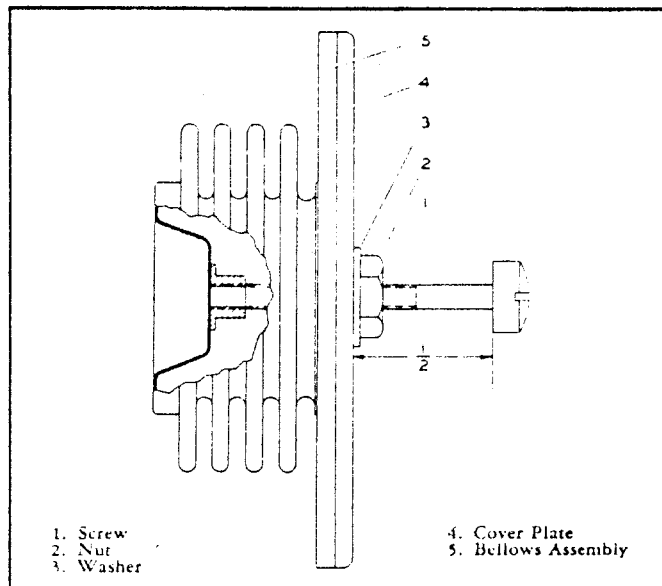

Figure 2-37. Preloading Bellows

- a. After assembly, the bellows must be preloaded in the following manner:
 - b. Obtain a fillister head screw, 3-56 x 1 inch long (AN501-3-16), nut, 3-56 (AN345-3), and plain washer for a size 3 screw (AN960-3).
 - c. Thread the screw into the lug located inside the bellows. Turn down the nut and washer, compressing the bellows until the distance between the cover plate (4, figure 2-37) and the head of the screw is $\frac{1}{2}$ inch. (If the screw is other than one inch long, subtract $\frac{1}{2}$ inch from its length. This then is the desired measurement).
 - d. Deleted.
 - e. Deleted.
 - f. With the sealing screws (1) removed, place the unit in a container filled with silicone fluid DC-200 having a viscosity of five centistokes so that the unit is completely covered by the fluid. The unit should be on its side with the filling hole facing up.
 - g. Place the container with the unit under a bell jar and evacuate to about one inch of mercury absolute (approximately -29 inches gauge pressure at sea level). Leave the unit in the evacuated bell jar for three hours.
 - h. Remove the container and unit from the bell jar, and position and tighten the sealing screws (1) and sealing rings (2) while the unit is still immersed in the fluid.
 - i. Clean the unit with an air hose and check for trapped air by swirling or shaking. Be sure that no bubbles appear beneath the lens when the unit is held upright.

j. If a bubble does appear, replace the unit in the container and bell jar with the lens up. Remove the two sealing screws (1). Evacuate and allow to stand in the vacuum for at least one hour.

k. Repeat steps h, i, and j as often as necessary to remove all the air from the unit.

l. After unit is sealed remove the screw (1, figure 2-37), nut and washer. Clean the unit with an air hose.

2-57A. PELLICLE. If skin of pellicle is wrinkled hold the pellicle above steam vapors of boiling water until the skin tightens which should take about 10 to 15 seconds. After the skin is noticeably tight, rotate the pellicle to accumulate condensation on lowest portion of the frame; then, using a camels hair brush, wipe off excess condensate.

CAUTION

Exercise extreme care while handling the pellicle. Do not touch the membrane as to do so will damage it, necessitating replacement.

2-58. DISASSEMBLY OF THE EYEPiece. (See figure 2-38.) Disassemble in the order of the index numbers assigned to the exploded view.

2-59. ASSEMBLY OF THE EYEPiece. Just prior to assembly, wash the eye lens mount, eyepiece mount and the lock rings with mild white bar soap and water to remove any foreign material. Rinse the parts in clean water and bake dry in an oven at 200°C (392°F) for one and one-half hours.

a. Lubricate the outer surface of the lens mount (47) with MIL-G-3278 grease or its equivalent.

b. Place the collective eye lens (49) onto the eyepiece mount (50) and turn the lock ring (48) into the eyepiece mount, securing the lens with reasonable pressure.

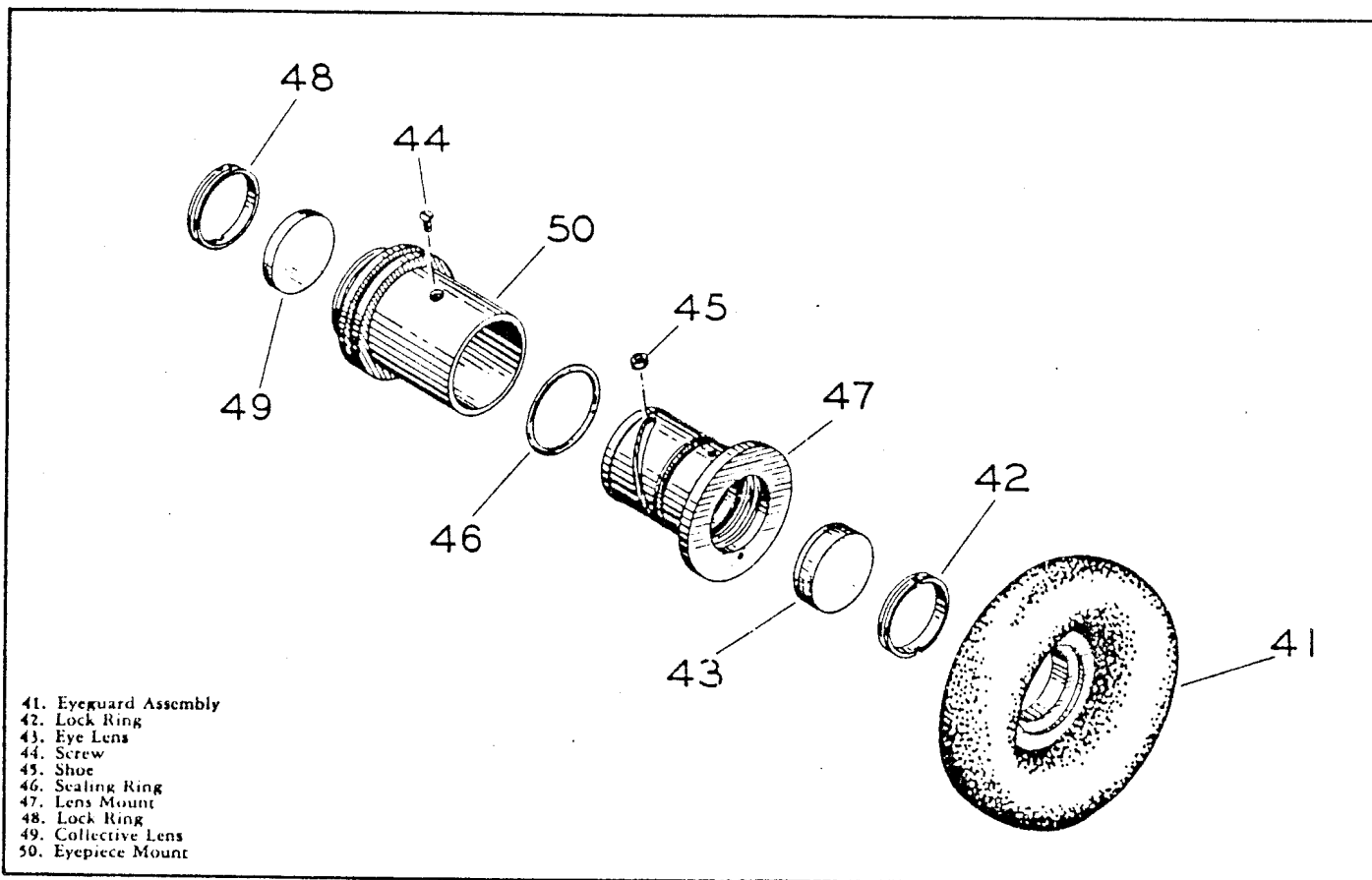

Figure 2-38. Eyepiece Assembly

c. Place the shoe (45), curved side out, into the slot of the lens mount (47). Lubricate and install the sealing ring (46).

d. Insert the eye lens mount into the eyepiece mount. Align the hole in the shoe with the hole in the eyepiece mount and secure the shoe to the eyepiece mount with one flat head screw (44).

e. Place the eye lens (43) on a suitable holding fixture with the crown side up.

f. Place the above assembled eyepiece over the fixture. Turn the assembly over and remove the fixture.

g. Follow the eye lens (43) with a lock ring (42) and make reasonably tight.

h. Screw eyeguard assembly (41) into the eyepiece.

2-60. LAMP HOUSING ASSEMBLY. (See figure 2-39,)

2-61. DISASSEMBLY. Disassembly follows the order of the index numbers assigned to the exploded view except for attaching parts.

2-62. REPAIR.

a. Check the lamp (34). Make sure that the lamp is operative and that the contact areas are clean.

b. Check the wiring for poorly soldered connections and for insulation breaks.

2-63. ASSEMBLY. Assembly follows the reverse order of the index numbers assigned to the exploded view.

2-64. INDEX HOUSING ASSEMBLY. (See figure 2-40.)

2-65. DISASSEMBLY. Disassembly follows the order of the index numbers assigned to the exploded view except for attaching parts and as noted below.

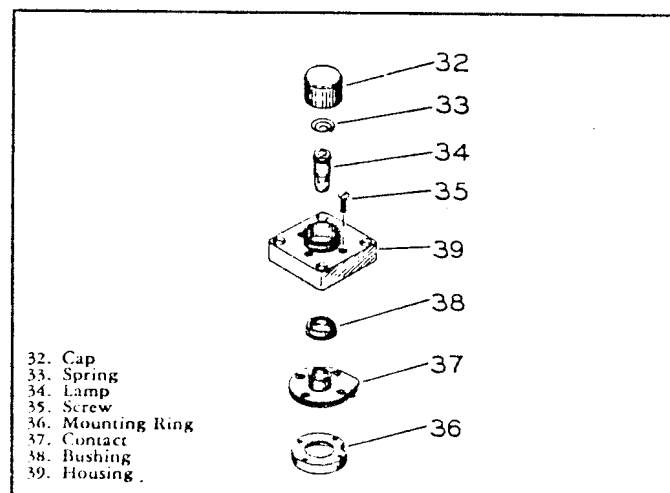
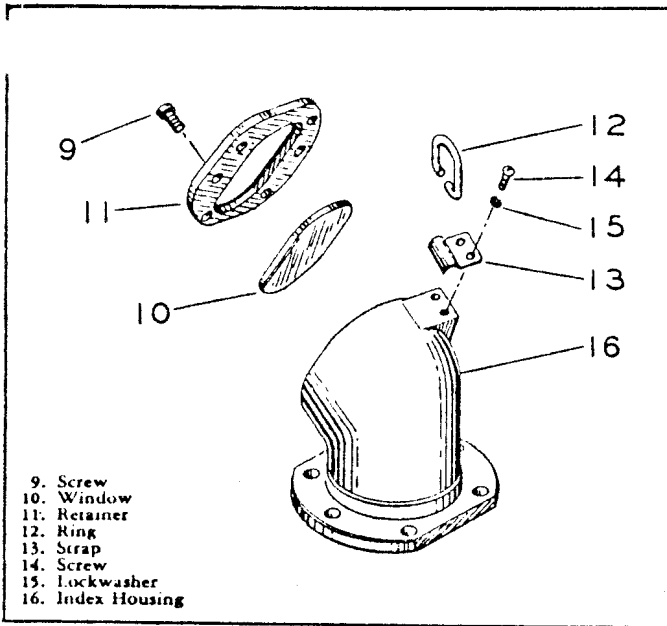

Figure 2-39. Lamp and Housing Assembly

Section II

T.O. 5N10-4-2-3

Paragraphs 2-65 to 2-67



- 9. Screw
- 10. Window
- 11. Retainer
- 12. Ring
- 13. Scrap
- 14. Screw
- 15. Lockwasher
- 16. Index Housing

Figure 2-40. Index Housing Assembly

a. Check the sealing compound about the window (10). It should feel hard and rubbery. If such is the case do not remove the window (10) from the retainer (11). Simply apply a bead of EC801 around the window edge and then follow procedures d through g in paragraph 2-66. If it feels soft and putty-like the following change should be accomplished.

b. With a sharp pointed tool remove as much of the compound as possible from the window. Lift the window from the retainer (11) and clean it thoroughly with ethylene dichloride.



When using ethylene dichloride, make sure the work is well ventilated.

c. Complete the cleaning as described in the note in paragraph 2-50. All traces of the old sealing compound should be removed from the window (10) and the retainer (11).

2-66. ASSEMBLY. Except for attaching parts, assembly follows the reverse order of the index numbers assigned to the exploded view.

a. The window (10) is cemented in place in the retainer (11) with Minnesota Mining Company's sealer EC801 mixed with EC1063 (See NOTE, paragraph 2-69A).

b. Spread the sealer freely around the inside diameter of the retainer. Make sure that the sealer is continuous around the inside diameter of the retainer.

c. Insert the window in the retainer and work it into the sealer until the glass rests flush against the flange of the retainer.

d. The cement should ooze from around the window rearward toward the mounting surface of the retainer. There must be a ridge of cement extending higher than the mounting surface of the retainer all around the opening. This ridge will provide a seal between the mounting surfaces of the retainer and the index housing (16) after the two are assembled.

e. Assemble the retainer (11) to the index housing (16) and secure with six screws (9).

f. Wipe all excess sealing compound from the window and housing immediately after assembling.

Note

There is no solvent for EC801. Removal of excess should be accomplished immediately, while the compound is in a liquid state.

g. Place the entire index housing assembly (figure 2-40) into an oven and bake at 70°C (158°F) for six hours.



Do not place the entire sextant in the oven, only the index housing assembly.

2-67. INDEX PRISM MOUNT ASSEMBLY. (See figure 2-41.)

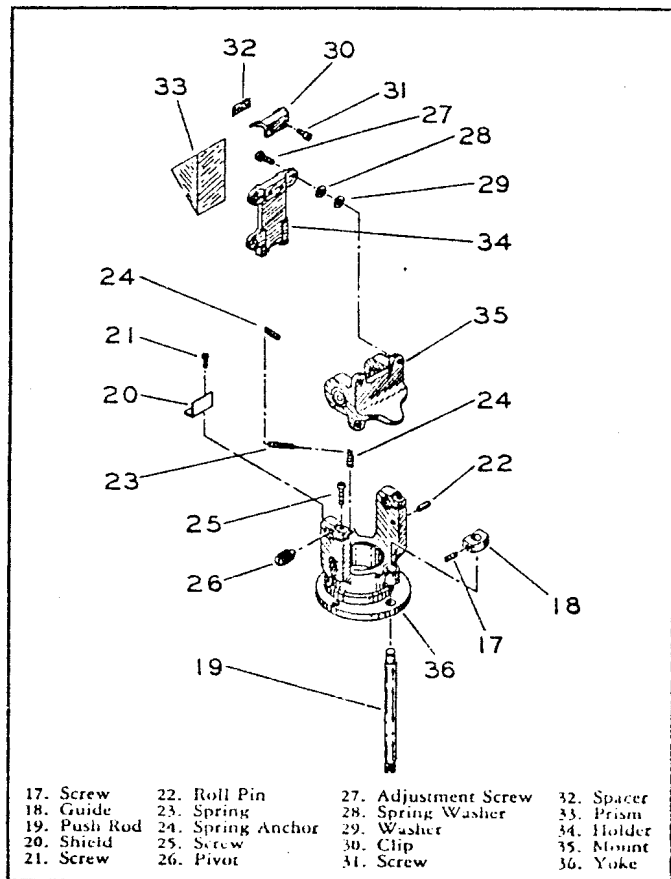

- | | | | |
|--------------|-------------------|----------------------|------------|
| 17. Screw | 22. Roll Pin | 27. Adjustment Screw | 32. Spacer |
| 18. Guide | 23. Spring | 28. Spring Washer | 33. Prism |
| 19. Push Rod | 24. Spring Anchor | 29. Washer | 34. Holder |
| 20. Shield | 25. Screw | 30. Clip | 35. Mount |
| 21. Screw | 26. Pivot | 31. Screw | 36. Yoke |

Figure 2-41. Index Prism Mount Assembly

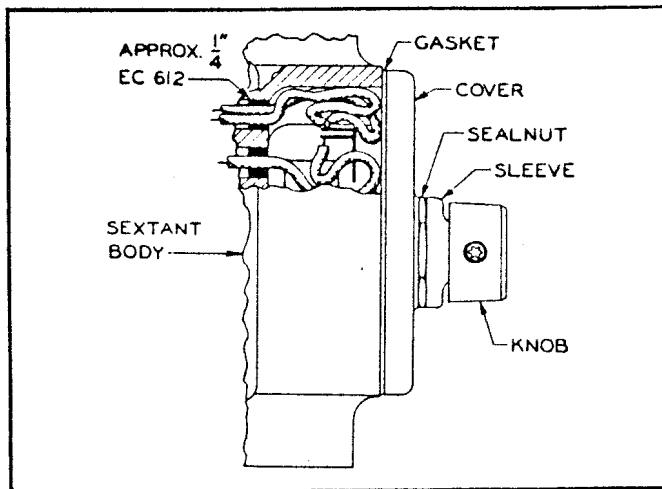

Figure 2-41A. Detail Rheostat Assembly

Note

This assembly requires careful adjustment and should not be disturbed unless replacement or repair of some component is necessary.

2-68. **DISASSEMBLY.** Disassembly follows the order of the index numbers assigned to the exploded view with the exception of attaching parts.

2-69. **ASSEMBLY.** Assembly follows the reverse order of the index numbers assigned to the exploded view.

a. When assembling the holder (34) with the mount (35), tighten the three adjusting screws (27) only to a point where the spring washers (28) are slightly compressed but not flat. Allow room for the adjustment of the assembly.

b. The pivots (26) should fit firmly against the bearing in the prism mount and ball assembly so as to allow free rotation of the assembly without end shake.

2-69A. **SEALING METHOD.** After a number of sextants had been shipped, several alterations were made to further seal the sextant against moisture. These alterations concern the index housing assembly, counter assembly, and rheostat and cover. The changes on the rheostat and cover are described below. The changes on the index housing and counter are described in the text which covers the overhaul of these assemblies. (See paragraphs 2-65, 2-66, 2-84 and 2-93p.) A kit has been assembled to facilitate the above mentioned alterations and is ordered as kit number 10199400010 from Kollsman Instrument Corporation, Elmhurst 73, N. Y. There are two sealing compounds, EC801 and EC612, and one drying accelerator EC1063, for EC801, required to perform the alterations. These compounds and the accelerator are manufactured by the Minnesota Mining Company.

Note

The EC801 must be mixed with EC1063 in a ratio of seven parts EC801 to one part EC1063 prior to application. Only mix sufficient for

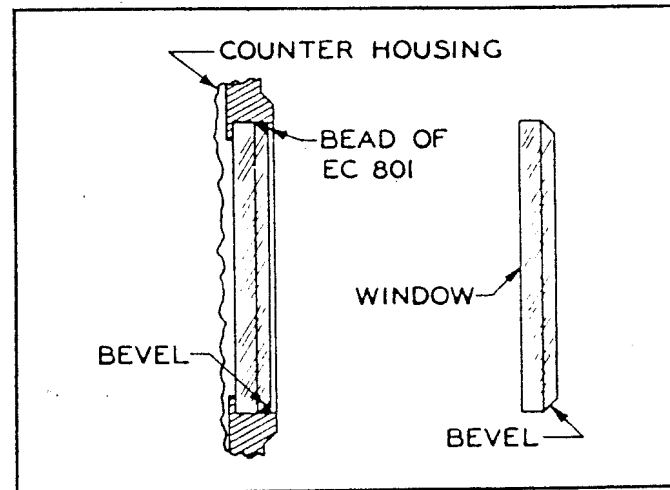

Figure 2-41B. Counter Window Bevel

the immediate use. After approximately three hours the sealer begins to set and is ineffective.

2-69B. **ALTERATION OF RHEOSTAT AND COVER.** (See figure 2-35.)

a. Visually inspect and check to see if the gasket (22), sealing nut (23), sleeve (24) and sealing ring (25), which are parts of the above mentioned kit, are used on the sextant.

Note

Care should be taken to insure that the sealing nut (23) is the same as that depicted in figure 2-35 with a flange for the sleeve (24), on one surface, and a groove for the sealing ring (25), on the other surface.

b. If the above named parts are not present, the following change should be made.

c. Remove the old nut and washer from the rheostat (26). These two parts may be discarded. From kit number 10 19940 0010 select the sealing nut, sealing ring, sleeve, and gasket.

d. Lubricate the contacting surfaces of the sleeve (24) and sealing ring (25) with DC33 and place them into position on the sealing nut (23).

e. Insert the rheostat shaft through the hole provided for it in the cover (19). Place the sealing nut with the sleeve and sealing ring on it, on the shaft and secure the rheostat to the cover.

f. Pack approximately 1/4 inch of EC612 into the holes where the wires enter the sextant body (See figure 2-41A).

g. Place the gasket (22) into position on the cover.

h. Prod the wires into the rheostat cavity and secure the rheostat and cover to the sextant body (63) with the two screws (20) and lockwashers (21).

i. Place the knob (18) on the rheostat shaft allowing a minimum amount of clearance between sleeve (24) and the knob (18) (see figure 2-41A). Secure the knob with a screw.

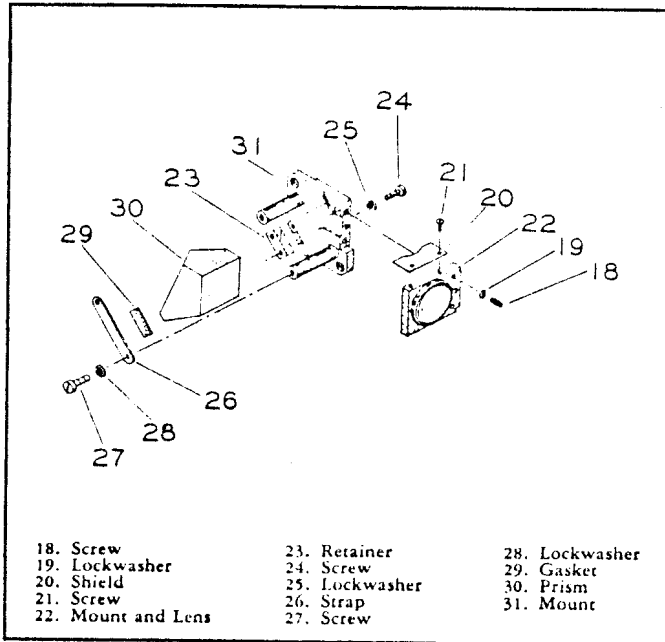

Figure 2-42. Prism and Lens Mount Assembly

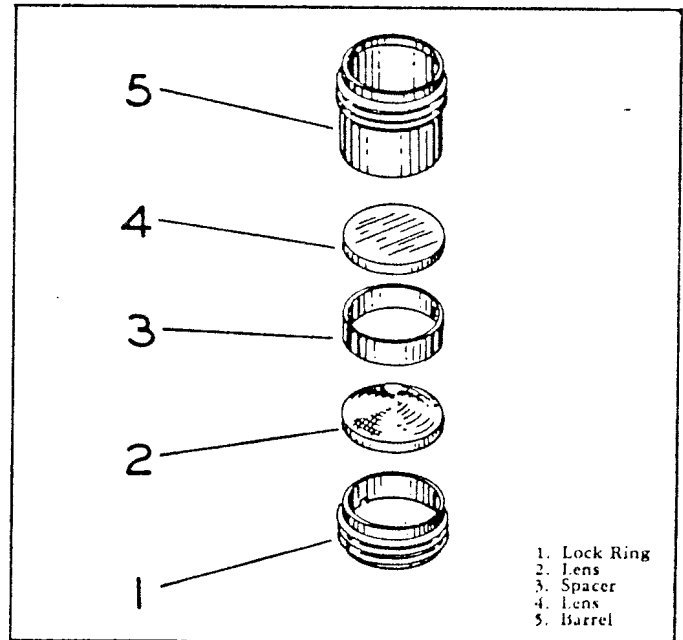

Figure 2-43. Condenser Lens Assembly

2-70. PRISM AND LENS MOUNT ASSEMBLY. (See figure 2-42.)

2-71. DISASSEMBLY. Disassembly follows the order of the index numbers assigned to the exploded view with the exception of attaching parts.

2-72. ASSEMBLY.

a. Assemble parts 20 through 22 forming the third objective lens mount assembly.

b. Assemble this assembly with the mount (31) and secure with three screws (18) and lockwashers (19).

c. Position the prism (30) in this partial assembly so that the 90° corner of the prism (as viewed in profile) fits snugly onto the corner formed by the third objective lens mount and the boss on the prism mount plate. The roof or gable of the prism should then be facing rearward and upward at a 45° angle.

d. Secure the prism in this position with parts 26 through 29.

e. Position the retainer (23) against the prism and secure with two screws (24) and lockwashers (25).

2-73. CONDENSER LENS ASSEMBLY. (See figure 2-43.)

2-74. DISASSEMBLY. Disassembly follows the order of the index numbers assigned to the exploded view.

2-75. ASSEMBLY.

a. The two lenses (2 and 4) in this assembly are identical. They should be positioned on the mount so that the convex surfaces are facing one another and separated by the spacer (3).

b. Assemble in the reverse order of the index numbers assigned to the exploded view.

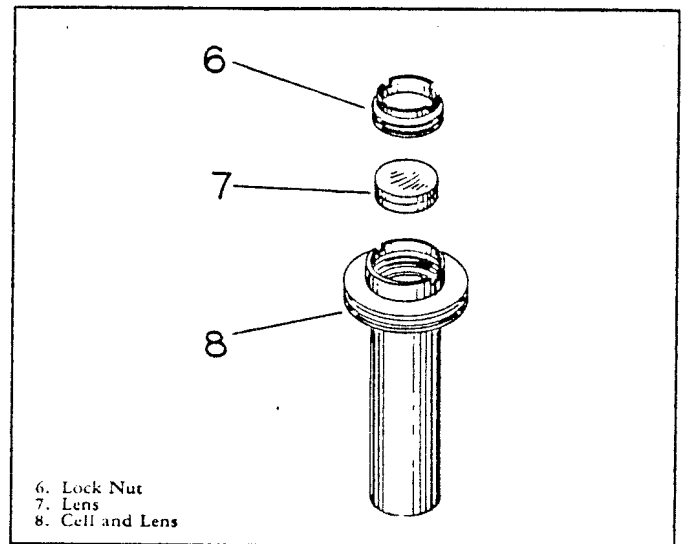

Figure 2-44. Objective Lens Assembly

2-76. OBJECTIVE LENS ASSEMBLY. (See figure 2-44.)

2-77. DISASSEMBLY.

a. This assembly contains two lenses only one of which is replaceable. If the lower lens has been damaged, the whole assembly must be replaced.

b. Before removing the upper lens, mark the top surface as a reference in reassembly.

c. Disassemble in the order of the index numbers assigned to the exploded view.

2-78. ASSEMBLY. Assemble in the reverse order of the index numbers keeping the indicated surface of the lens upward.

Section II

T.O. 5N10-4-2-3

Paragraphs 2-79 to 2-80

2-79. DISASSEMBLY OF THE LEFT COVER ASSEMBLY. (See figure 2-45.) Except for attaching parts the disassembly procedures will follow the order of the index numbers assigned to the exploded view.

2-80. ASSEMBLY OF LEFT COVER. Except for attaching parts the assembly procedures are essentially the reverse of the index numbers assigned to the exploded view.

Note

The lower filter must be positioned with the index knob assembly indicating zero and the clear filter over the opening in the mounting plate.

a. Place the pinion (21) on its shaft (shoulder down) and position it so that the first tooth (between the clear

and the red filters) engages the intermittent gear in the left tooth of the cutout. (See figure 2-46.)

b. When mounting the filter and shutter assembly to the left cover, allow 0.237 inch clearance between the cover mounting surface and the facing surface of the shutter actuating lever. A gauge, such as is shown in figure 2-47 will facilitate this alignment.

Note

Position the upper filter assembly so that the clear filter is above the clear filter of the lower filter assembly and both are over the opening in the mounting plate when the index knob indicates zero.

c. Use washers (7A) as required for 0.001 to 0.006 end play on lever shaft (8).

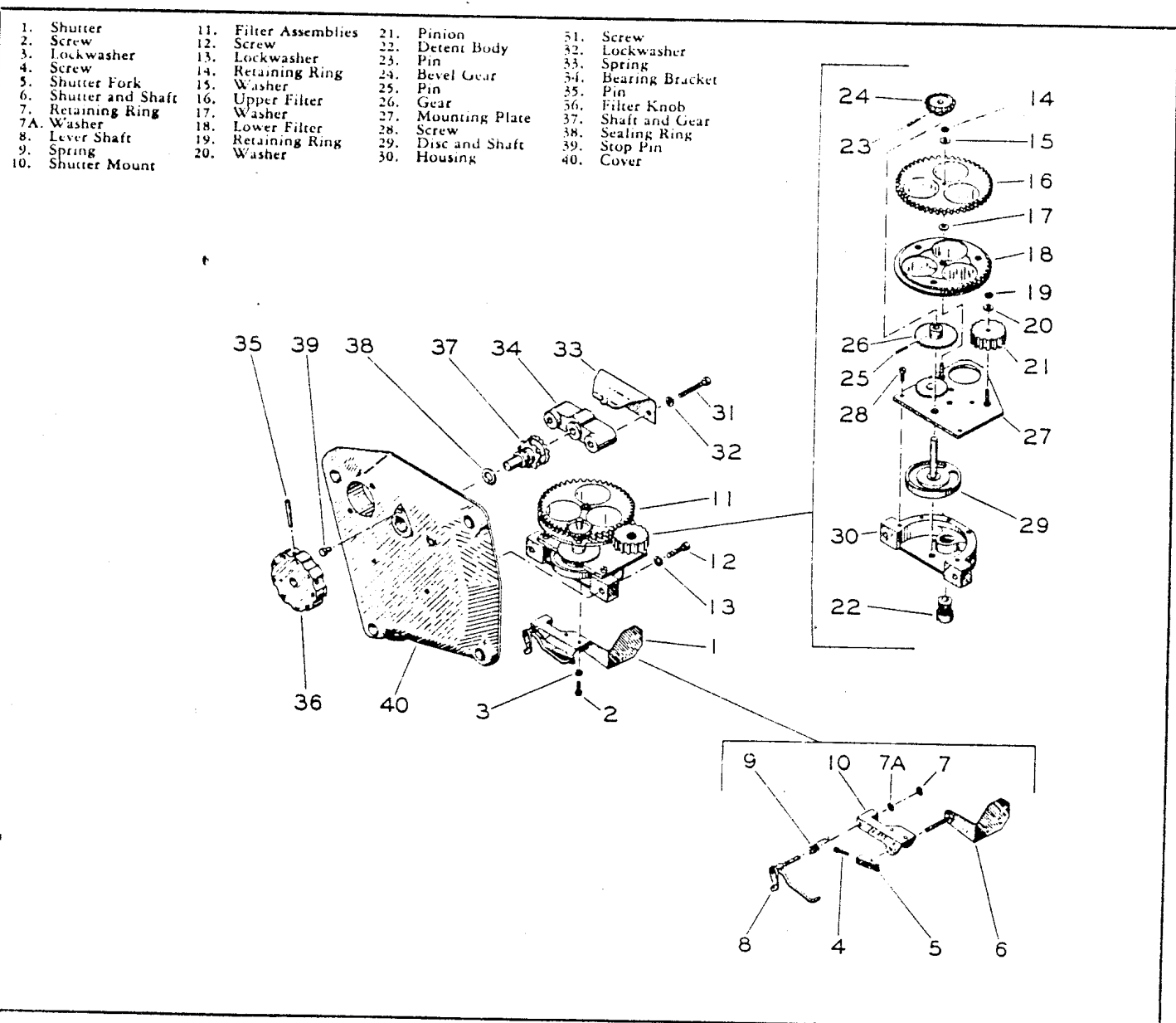

Figure 2-45. Left Cover Assembly

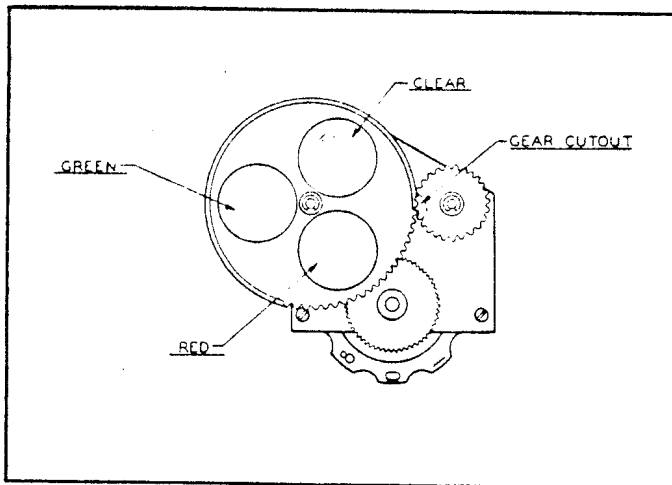

Figure 2-46. Lower Filter and Pinion Assembly

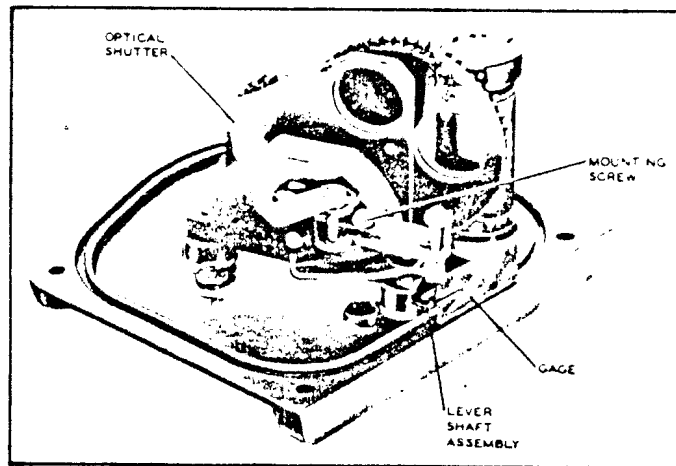

Figure 2-47. Detail—Shutter Actuating Lever

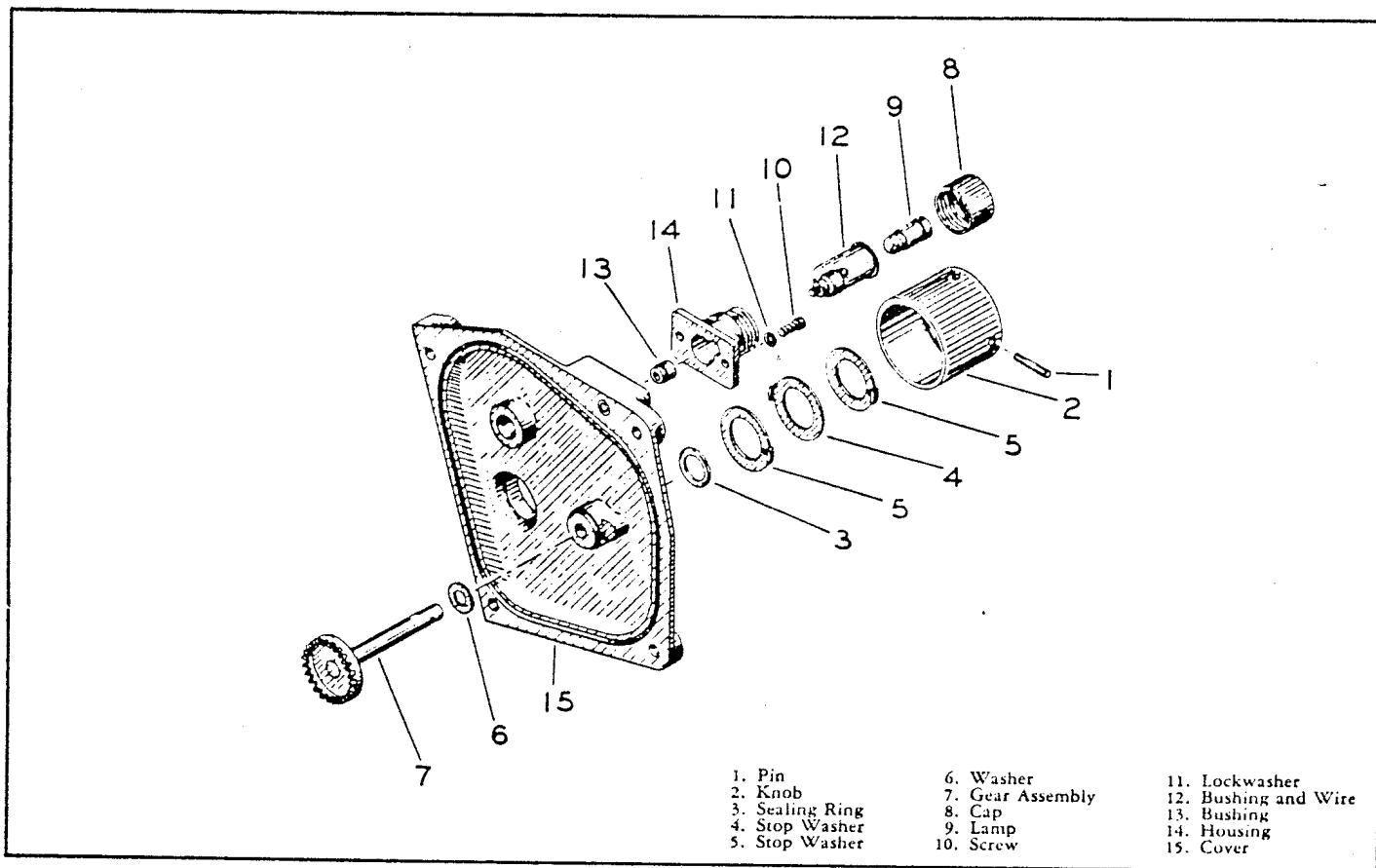

Figure 2-48. Right Cover Assembly

2-81. DISASSEMBLY OF THE RIGHT COVER ASSEMBLY. (See figure 2-48.) Except for attaching parts the disassembly procedures will follow the order of the index numbers assigned to the exploded view.

Note

To ascertain the direction of the taper, position the knob with the taper pin in a horizontal position and the third hole in the knob on top. To remove the pin, drive it from right to left.

2-82. ASSEMBLY OF RIGHT COVER. Except for at-

taching parts the assembly procedures are essentially the reverse of the index numbers assigned to the exploded view.

a. Insert the gear assembly (7) into the bushing. Place one stop washer (5) on the shaft of the gear assembly with the locating pin of the cover assembly in the hole in the washer.

b. Place twenty-three more stop washers (4) in any combination to obtain 0.005 end play of the shaft on top of the above washers with the tabs up and along-

Section II

T.O. 5N10-4-2-3

Paragraphs 2-82 to 2-84

...e each other. Place another stop washer (5) on top of the above washers in the same position.

c. Place the knob and pin assembly on the shaft with the locating pin of the knob assembly in the hole of the top washer. Determine the direction of the taper and secure the parts with a taper pin (1).

d. Rotate the knob in either direction until it stops. When rotated in the opposite direction, from this point, the shaft should revolve approximately $30\frac{3}{4}$ times until it is stopped again. If such is not the case, remove the knob and observe the position of the tabs on the stop washers. They must not be broken and must all face the same direction.

e. Attach the right cover assembly to the sextant housing with two screws, meshing its gear with the gear of the main shaft.

f. Rotate the knob (2). If it binds or turns hard, remove the cover assembly from the sextant housing. Remove the shaft and substitute a thinner thrust washer (6). Reassemble the cover to the sextant housing. The thickness of the thrust washer is determined by the gear mesh. The mesh movement as measured on the periphery of the knob should not exceed 0.003 inch.

2-83. DISASSEMBLY OF THE COUNTER ASSEMBLY. (See figure 2-49.) The disassembly procedures will

follow the order of the index numbers assigned to the exploded view.

Note

Do not disassemble index numbers (24) and

(25) further than indicated. If either part is damaged it must be replaced as an assembly.

2-84. ASSEMBLY OF COUNTER.

a. All shafts and bearing surfaces are lubricated with a moderate amount of a suitable oil (MIL-L-6085A or equivalent).

b. Place the counter drum unit (25) on the gear and bushing (24) so the gears of the drum units are adjacent to the driving gear and bushing assembly.

c. Insert the flange (23) into the drum (22). Align the screw holes in the flange and the drum. Place the drum (22) and flange (23) on the squared end of the shaft so that the 26.5-minute value is aligned between the teeth of the gear and bushing (24). Secure the minute drum on the shaft with the locknut (21). The shoulder of the locknut should be facing out.

Note

The centerline between the teeth of the gear and bushing (23) must be on the 26.5-minute value of the drum (21) within ± 30 minutes of arc. (See figure 2-51.)

d. Tighten the locknut until the screw holes are aligned. Insert and tighten the screw (20).

e. Before replacing the window (18) check to see that all the old cement has been removed from the window and the window contacting surfaces on the rear housing (10) and front housing (16).

f. Visually inspect the window edges. The edges which

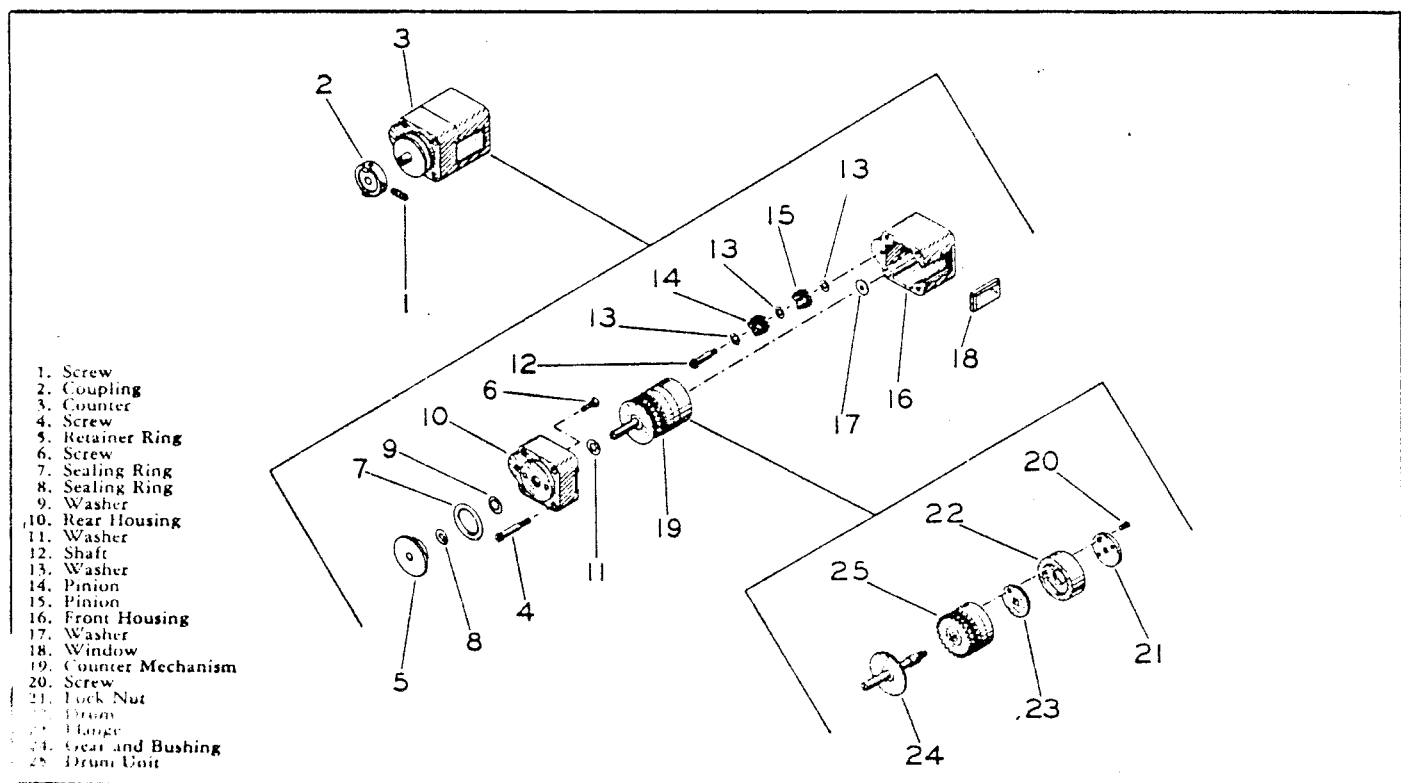

Figure 2-49. Counter Assembly

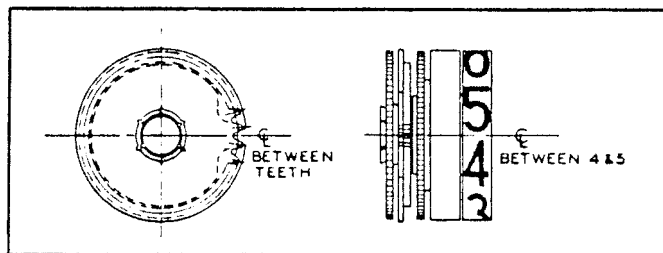

Figure 2-50. Counter Tooth Alignment

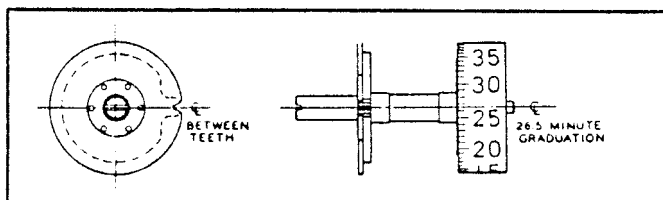

Figure 2-51. Counter Centerline Position

face away from the counter should be slightly beveled as in figure 2-41B. If the window is not beveled a fine file can be used to bevel it.

g. Clean the window thoroughly.

h. Place the washer (11) over the slotted end of the shaft of the counter mechanism (19). Place the front (16) and rear (10) housing and bearing assemblies onto their respective ends of the counter mechanism.

i. Determine by the amount of end play how many washers (17) must be used to limit the end play to 0.003 inch.

j. Remove the rear housing (10).

k. Position the counter drums and the shaft so that the drive teeth are one above the other and are on the centerline between the shaft and the tapped pinion shaft hole.

l. Place a washer (13) over the tapped pinion shaft hole. Place the brass pinion (15) on the above washer so that either of the four full teeth are engaged with the driving gear of the drum unit. Place a washer (13) in the brass pinion gear and engage the full tooth of the steel pinion (14) with the driving gear of gear and bushing (24).

Note

The washers (13) are of different thicknesses and are to be used when and as required to permit satisfactory counter operation.

m. Insert the pinion shaft (12) through the washers (13) and the two pinions (14 and 15). Turn the screw in, securing the parts.

Note

The end play of the pinion gears should be approximately 0.002 inch. Select the washers (13) which will allow this tolerance.

n. Secure retainer ring (5), sealing rings (7 and 8) and washer (9) to rear housing with screw (6).

o. Lightly coat the contacting surfaces of the rear

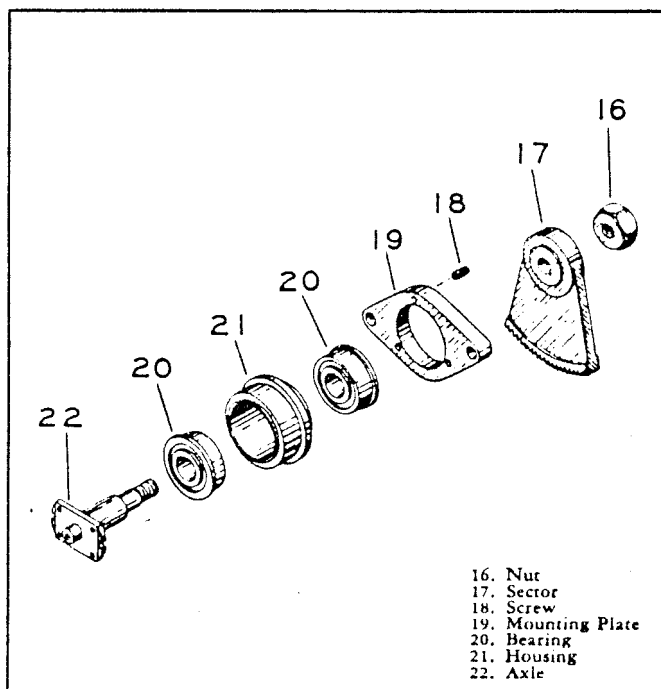

Figure 2-52. Axle and Sector Assembly

(9) and front (15) housings with EC801 mixed with EC1063. (See NOTE, paragraph 2-69A.)

CAUTION

Do not apply EC801 in excess about these surfaces or it will ooze into the counter when the housings are assembled and affect the operation of the counter.

p. Assemble the rear housing (10) and front housing (16). Secure them with two screws (4) and pack the hole over the pinion shaft (12) in the rear housing with EC612. (See paragraph 2-69A.)

q. With bevel facing outward center the window (18) in position in the counter housing. Lay a bead of EC801 around the beveled edge of the window. (See figure 2-41B.) Remove excess as described in paragraph 2-66f.

Note

While waiting for the EC801 to dry cover the cavity in the sextant body with a cardboard cover to prevent moisture and dirt from getting into the sextant.

2-85. DISASSEMBLY OF THE AXLE AND SECTOR ASSEMBLY. (See figure 2-52.) Disassembly procedures will follow the order of the index numbers assigned to the exploded view.

2-86. ASSEMBLY OF THE AXLE AND SECTOR. Items 20, 21 and 22 are hand fitted and the components are not readily interchangeable. If any of these components are defective the assembly consisting of these three pieces must be replaced. All other parts are interchangeable.

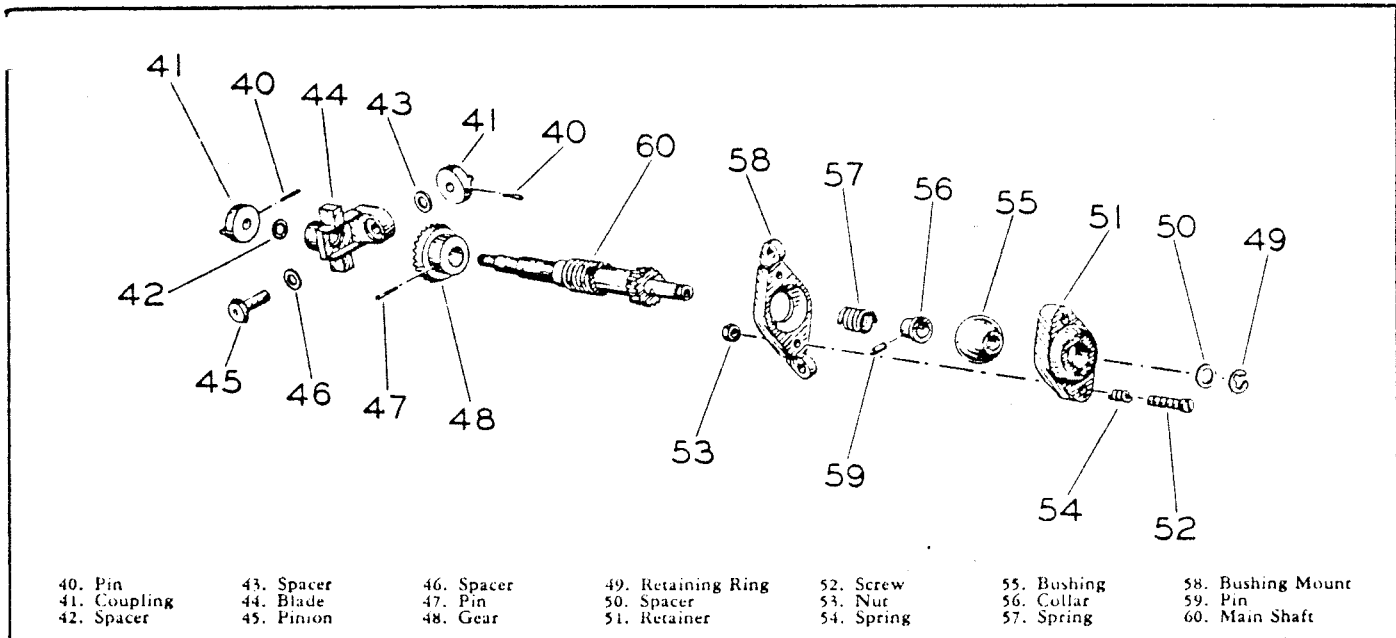

Figure 2-53. Main Shaft Assembly

2-87. DISASSEMBLY OF THE MAIN SHAFT AND PINION ASSEMBLY. (See figure 2-53.) Disassembly procedures will follow the order of the index numbers assigned to the exploded view.

2-88. ASSEMBLY OF THE MAIN SHAFT AND PINION. Assembly procedures are essentially the reverse order of the index numbers assigned to the exploded view.

a. Assemble 40 through 48 to the main shaft (60).

b. Lubricate outer surface of ball bushing (55) with grease (MIL-G-3278). Place it into the bushing mount (58) and hold it in place with the bushing retainer (51). Hold parts together with two screws (52), springs (54) and elastic stop nuts (53).

c. Insert torque rod (TE5791) and adjust spring tension until shaft will fall of its own weight with some drag.

d. Insert main shaft (60) into universal assembly. Install shaft and universal in casting and secure with screws (53 and 60, figure 2-35).

e. Adjust screws (55, figure 2-35) to eliminate up and down play of the shaft but to allow sliding side play.

f. Install and test action of post and spring assembly (46, figure 2-35). Spring must have sufficient force to push bearing block to opposite end of guide.

2-89. FIELD LENS. (See figure 2-54.)

a. Disassembly follows the order of the index number assigned to the exploded view.

Note

The lens (52) is cemented into this unit. Removal is not advised unless the lens is damaged and requires replacement.

b. ASSEMBLY. Assembly follows the reverse order of the index numbers assigned to the exploded view.

Note

After the assembly has been reassembled, the cross hairs must align with the flat edge on the housing as shown in figure 2-55.

2-90. LUBRICATION.

2-91. GENERAL. All lubricants must be applied sparingly; only those parts listed below should be lubricated. (Spec. MIL-G-3278 and MIL-L-6085A.)

a. Ball socket of main shaft (MIL-G-3278).

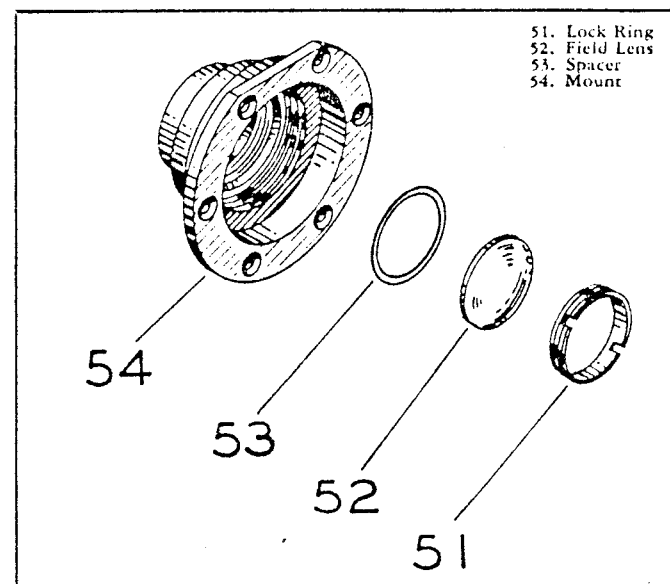

Figure 2-54. Field Lens Assembly

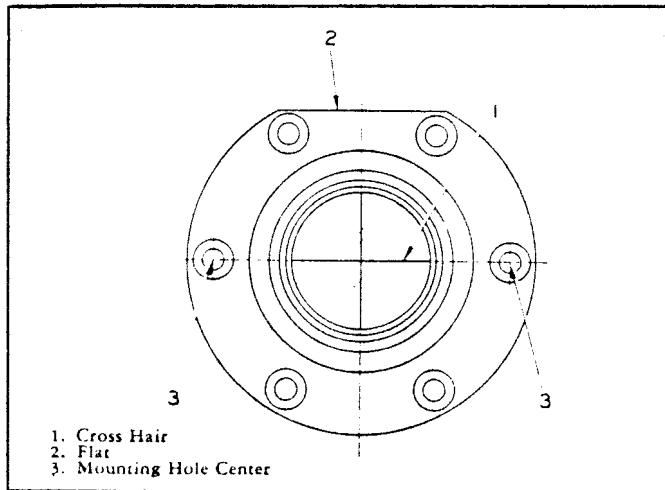

Figure 2-55. Reticle Alignment

- b. Gear, pinion and bearing clamp of main shaft (MIL-G-3278).
- c. Stop washers of right cover (MIL-G-3278).
- d. Shafts of counter assembly (MIL-G-6085A).
- e. Sector and worm gear in main body (MIL-G-3278).

2-92. REASSEMBLY.

2-93. ASSEMBLY OF THE SEXTANT. (See figure 2-35.)

a. Lubricate the legs of the bearing clamp (56 and 59) with MIL-G-3278 grease or equivalent, and secure it to the casting with two screws (57) to eliminate up and down play of the shaft but to allow sliding side play.

b. Guide the axle assembly (39) through the hole in the mechanism body. Align the axle mounting plate with the holes in the casting and secure it with two screws (40) and lockwashers (41).

c. Lubricate the teeth of the sector and the worm on the main shaft with MIL-G-3278 grease or equivalent. Rotate the main shaft until the sector and worm gears have run themselves in and operate smoothly.

Note

If necessary, loosen the adjusting screw (55) and move the main shaft aside to allow the sector to clear it. After the sector is in mesh with the shaft, adjust the position of the screw so that the maximum side play of the shaft when in mesh with the sector is 0.001 inch.

- d. Screw the objective lens (14) into the housing.
- e. Spread a small amount of MIL-G-3278 grease or equivalent on the barrel of the reticle mount (2) and install.
- f. (See figure 2-34.) Mount the field lens (30) to the casting with six flat head screws (31). The reticle should be on the vertical and horizontal axes.
- g. Mount the eyepiece (28) to the casting and tighten with wrench TE5950.

h. Temporarily attach the left cover (14) to the casting with four screws (15).

i. Mount the sextant on the adjustable assembly stand (TE5167) and position it so the left cover assembly is on top.

j. Using a single collimator (TE5998) set at infinity, sight into the objective lens assembly (14, figure 2-35). Loosen the lock ring and adjust the position of the objective lens assembly to obtain sharpest focus of the reticle in the field lens assembly (30, figure 2-34). Secure the objective lens assembly in this position with the lock ring. This adjustment must be made only when the filters of the left cover assembly are in the optical path.

k. Secure the index prism mount assembly (10, figure 2-34) to the body. The push rod must pass freely through the guide on the index prism mount assembly and the matching clearance hole in the body casting.

l. (See figure 2-34.) Position the mount (3) on the casting and secure it with four screws (4) and lockwashers (5). Position and secure the lamp and housing (1) with four screws (2).

m. Position and secure the pellicle (5, figure 2-35) with two screws (6).

n. (See figure 2-34.) Secure the mirror unit (33) into the sextant housing and lock in position with the three stop screws (3, figure 2-36).

CAUTION

Do not screw the mirror unit in too far as it may strike the pellicle.

o. Mount and secure left cover (14) with four screws (15) and lockwashers (16).

CAUTION

If care is not exercised during this installation the filter assembly may strike the thin membrane of the pellicle and damage it.

p. Place the gasket (21) in position on the rear counter housing. Attach the counter to the right cover (24, figure 2-34) with two screws (19) and fill the recesses above the screws with EC612.

q. Before assembling the right cover (24) to the sextant body, adjust the worm and sector assemblies to its mid-point of travel.

r. Set the knob of the right cover assembly to its mid-point of travel which is approximately 10 turns from either stop. Adjust the counter to indicate approximately 45 degrees and align the coupling of the pinion shaft and the coupling on the right cover assembly. Place a floating disk on the coupling of the pinion shaft of the main shaft assembly and mount the right cover (24) on the sextant body with four screws (25) and lockwashers (26). Rotate the altitude knob through its entire range and check the counter indication. The readings should be approximately 92 degrees at one

Paragraphs 2-93 to 2-98

end to minus ten degrees from zero at the other end of the knob travel.

2-94. CALIBRATION OF THE SEXTANT.

2-95. COLLIMATING EQUIPMENT (TE5194D). The three collimating tubes should be mounted on a sturdy, vertical surface and position at 0, 45 and 90 degrees and in a plane parallel to the surface. A Holding Fixture (TE5954) is provided to hold the pivot point of the adjustable prism mount at the intersection of the centerline of the collimating tubes.

2-96. INDEX PRISM LATERAL ERROR ADJUSTMENT. Purpose of test is to check the axis of rotation of the index prism by determining whether the field lens reticle is coincident with the reticle points of the collimators throughout the altitude range of the sextant.

a. Position the sextant in Holding Fixture TE5954 which in turn is secured to Collimator TE5194D.

b. Rotate the altitude knob of the sextant until the vertical collimator is visible through the eyepiece.

c. Position the sextant until the reticle of the sextant field lens and the reticle of the collimator are coincident in this position.

d. Sight into the eyepiece and rotate the altitude knob until the reticles of the 45° and 0° collimators can be compared with the reticle of the field lens. If the reticles at 90° are coincident and at 45° and 0° they have laterally separated, readjust the position of the index prism with the adjustment screws. (See figure 2-56.)

2-97. SEXTANT TILT ADJUSTMENT. (See figure 2-57.)

a. Purpose of Test: Provisions have been made on the artificial horizon to permit its adjustment to keep the objective body and the artificial horizon coincident within 3 minutes of arc when the sextant is displaced fore and aft up to 5° from the vertical position.

b. Align the reticles of the artificial horizon and the field lens with the reticle of any collimator. Swinging the instrument fore and aft approximately 5° either side of the vertical, the artificial horizon should not separate from the reticle of the collimator by more than three minutes. As a guide, assume the width of the long axis of the artificial horizon to be one minute.

c. To accurately determine the amount by which the artificial horizon and the collimator reticle are out of coincidence, read the altitude angle on the counter. Sight into the eyepiece and rotate the altitude knob, bringing the artificial horizon and the reticle in the collimator into coincidence. Read the altitude angle on the counter. The difference will be the error and it should not exceed three minutes.

d. If adjustments are required, remove the four filler head screws and left cover. Loosen screw (1, figure 2-58), rotate the reticle mount (2) one-half revolution at a time clockwise or counterclockwise. The errors

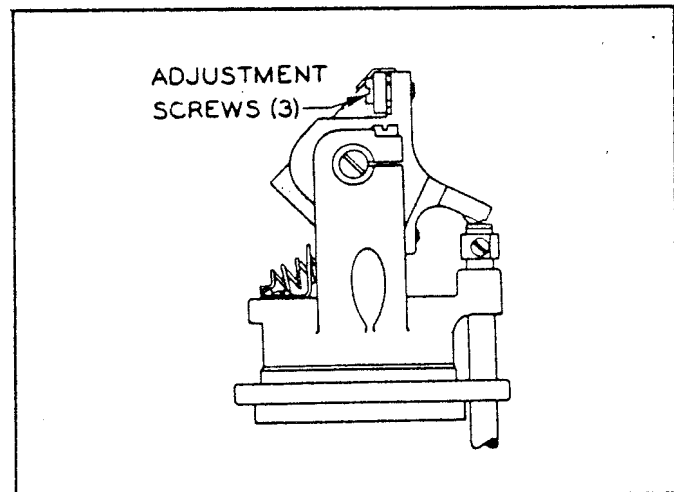

Figure 2-56. Index Prism Adjustment Screws

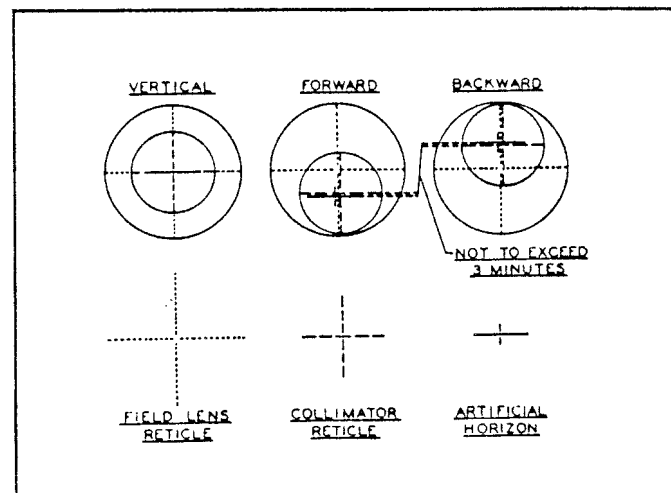

Figure 2-57. Position of Reticle on Tilt Test

are identified as plus errors when the artificial horizon has traveled beyond the collimator reticle. If the artificial horizon should lie between the field lens reticle and the collimator reticle, the error will then be identified as minus.

e. To correct a plus error, turn the reticle mount (2) counterclockwise one-half revolution at a time. The reason for the half revolution is to keep the long leg of the artificial horizon parallel to the horizontal axis of the field lens.

f. To correct a minus error, turn the artificial horizon lens assembly clockwise one-half revolution at a time.

g. When the best possible adjustment has been obtained, secure the assembly in the sextant body. Focus the reticle by adjusting the mirror unit.

2-98. POSITION OF THE INDEX PRISM RELATIVE TO THE ALTITUDE COUNTER. Purpose of test is to determine the error of the angle of the index prism as determined by the collimating equipment and the reading as indicated on the altitude counter.

a. Adjust the position of the sextant so that the horizon reticle and the two reticles (field lens and the 45° position of collimator) are coincident.

b. Observe the counter indication. It should be 45 degrees. If not, remove the counter and position the coupling on the end of the counter shaft to read approximately 45 degrees when the counter is attached to the sextant.

c. Record the readings of the counter when the altitude knob is rotated until the horizon reticle and two reticles are coincident at the zero-degree, 45-degree and 90-degree positions. Assume that the following listing for the three positions is obtained.

Collimator Test Point	Counter Indication
90°	90°0'
45°	45°10'
0°	0°20'

d. In order to make the 45° position zero, it is necessary to subtract 10' from all values, therefore the
 90°0' becomes 89°50' or -10'
 45°10' becomes 45° or 0
 0°20' becomes 0°10' or +10'

e. If we consider the signs of the above derived values, 90 is minus, 45 is zero and 0 is plus. From the table below we can select the adjustment which best suits the instrument.

Test Point	Adjustment A	Adjustment B	Adjustment C	Adjustment D
90	-	+	+	-
45	0	0	0	0
0	-	+	-	+
	lengthen rod	shorten rod	lengthen arm	shorten arm

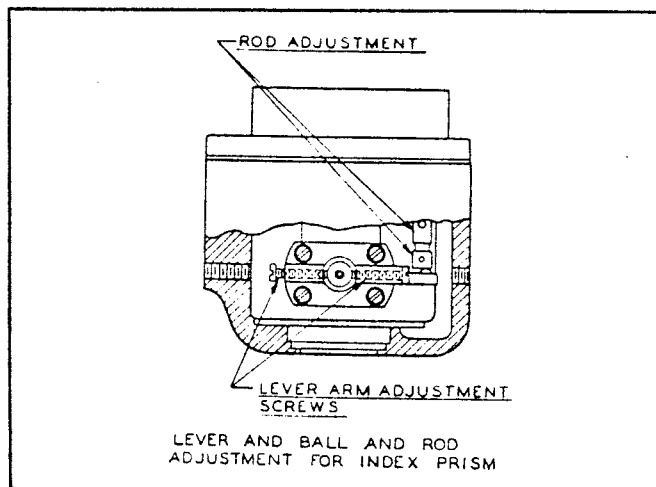

Figure 2-58. Index Prism Adjustment

f. In this particular instance column D is best suited. The corrective step to be taken is indicated in column "D" and figure 2-58 illustrates where the adjustments are to be made. In order to adjust the length of the push rod, a small, pointed tool may be used.

g. Repeat the test until the three positions are within one minute. In the final stages of adjustment the mere tightening of one screw more than the other may be sufficient to correct a small error. Tighten the four fillister head screws in rotation a little at a time. Remove the counter from the cover. Loosen the set screw and position the coupling on the counter shaft to indicate the correct position. The counter should be adjusted to have 10° back movement from zero degrees.

2-99. FINAL ASSEMBLY OF THE SEXTANT.

a. Attach all of the remaining parts to the sextant body.

b. After the averager has been tested and adjusted, position it on the completed sextant so that the coupling on the main shaft of the sextant is engaged with the mating coupling of the averager. Secure the averager to the sextant with four fillister head screws.

c. Use care when replacing the averager to be sure that the shutter actuating push rod in the averager aligns exactly with the shutter-actuating lever protruding from the rear of the left cover. The mounting screw clearance holes in the averager are oversized and will permit this adjustment.

2-100. FILLING THE SEXTANT WITH 'DRY NITROGEN. After each overhaul the inner chambers of the sextant must be evacuated and filled with dry nitrogen. Examine the silica gel of the desiccator to determine the extent of the moisture content in the tube. If the top layer of the silica gel crystals has turned pink and the balance of the crystals are blue, it is only necessary to replace the desiccator with a new one. However, if condensate is visible in the optical system or if the silica gel crystals of the left cover assembly indi-

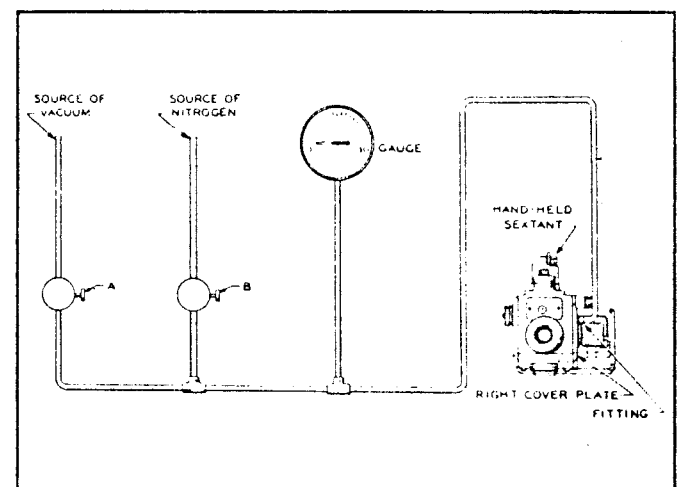

Figure 2-59. Filling with Dry Nitrogen

icates moisture content, the sextant must be filled with dry nitrogen and sealed. The procedure is as follows.

a. Remove the sealing screw assembly in the right cover of the sextant and insert a suitable fitting in its place. Connect brass or copper tubing to the fitting and to tees, valves, a gauge and sources of vacuum and dry nitrogen as indicated in figure 2-59. The pressure at the source of nitrogen should be between 15 and 25 psi.

CAUTION

Be sure that no dirt, grease or other foreign matter is present in the system. Do not use rubber tubing.

b. Open valve A. When the gauge indicates 30 in. Hg (vacuum), close valve A and observe gauge for a one-minute period. If the gauge indication falls during this period, a leak in the sextant is evident. If a leak is indicated, check all gaskets on the sextant. Replace gaskets as required.

c. If the reading on the gauge remains constant, open valve A and apply vacuum to the sextant for a period of 15 minutes.

d. Then close valve A and open valve B very slightly allowing nitrogen to fill the sextant very slowly until gauge reads zero in. Hg.

Note

The needle on the gauge should travel from 30 to zero in. Hg in approximately one minute.

e. Close valve B. Allow the nitrogen to remain in the sextant for five minutes. Care should be taken not to let the pressure of nitrogen within the sextant exceed 15 psi above atmospheric pressure.

f. At the end of the five-minute period, open valve A and evacuate the sextant for 15 minutes.

g. At end of the 15-minute period repeat the procedure described in steps d and e above.

h. Repeat step f above.

i. At the end of the 15-minute period, refill the sextant with nitrogen for five minutes. Then remove the fitting from the sextant and insert screw and washer as quickly as possible to prevent the entrance of moist air.

Note

On occasion, drying the sextant may be accomplished by the repeated replacement of the silica gel indicator.

2-101. INTERNAL WIRING. Internal wiring of the sextant is schematically illustrated in figure 2-60.

2-102. CARRYING CASE ASSEMBLY. Examine the case for evidence of deterioration or loose fitting parts. All rubber nests, bumpers and gaskets should be securely cemented in place with Armstrong's Cement D236, manufactured by the Armstrong Cork Co., N. Y. C. All damaged parts should be replaced.

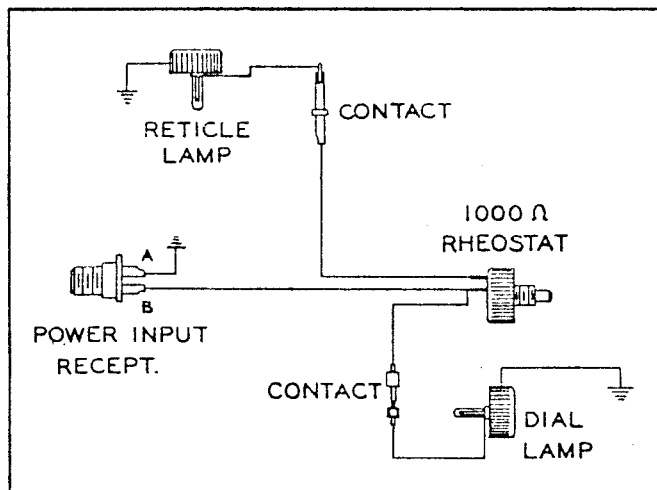

Figure 2-60. Wiring Diagram

**SECTION III
TEST PROCEDURE**

3-1. TEST PROCEDURES.

3-2. GENERAL. Each sextant shall be subjected to the following tests in the following order.

3-3. EXAMINATION OF PRODUCT. Each sextant and case shall be inspected to determine conformance with this specification with respect to materials, workmanship and envelope.

3-4. REMEDIAL ACTION. Replace all burred screws or damaged parts. Retouch imperfect paint with dull black lacquer.

3-5. SCALE ERROR. Each sextant shall be tested for scale error at five points: minus 1, 0, 1, 45, and 90 degrees of angular altitude with the horizon reference line centered on the cross hairs, or at any other points selected at the discretion of the testing agency with both increasing and decreasing readings. The permissible error at any point is two minutes of arc. Lateral displacement of the reference centers shall not exceed five minutes of arc.

3-6. REMEDIAL ACTION. If there are excessive errors in altitude, the sextant may be adjusted as described in

paragraph 2-98. If there is excessive lateral displacement, refer to paragraph 2-96.

3-7. SHADE GLASS. Each sextant shall be tested to determine the error due to the shade glasses. The use of any shade glass shall not introduce secondary images in the line of sight or cause a change in the altitude reading of more than 30 seconds.

3-8. REMEDIAL ACTION. In the event of failure of this test, replace the defective filter assembly.

3-9. FOREIGN PARTICLES. Foreign particles in the field of view shall be counted and weighed as described below.

Size (in inches)	Count
below 0.0004	1
0.0004 to 0.001	4
0.001 to 0.004	10

a. Particle size may be estimated by comparison to the etched reticle lines which are 0.0008 inch wide.

b. In a five-degree field surrounding the center of the field of view, the total weighted count shall not exceed eight.

c. The remainder of the field of view shall not exceed a total weighted count of 30.

d. The areas described can be estimated by comparison with the total field which is 15 degrees.

3-10. REMEDIAL ACTION. Disassemble the sextant and clean the component or components that contain the particles.

3-11. SLIPPAGE. The averager shall be operated for the maximum possible time interval and the altitude setting noted after bringing the indices into coincidence. Without rewinding the mechanism, the knob shall be rapidly oscillated 5 degrees from its setting. After a minimum of five cycles, the indicator shall be brought into coincidence. The altitude setting then obtained from the averager shall not differ from that previously obtained by more than two minutes of arc. To eliminate the effect of backlash from this test, both altitude readings shall be obtained as the primary element of the averaging indicator is brought into alignment by rotation of the knob in the same direction as that of the start of the cycles. This test may be combined with other tests if desired.

3-12. REMEDIAL ACTION. Adjust spring tension of averager as described in paragraphs 2-40 and 2-41.

3-13. MULTIPLE SETTING. With the altitude setting at some chosen value, the averager shall be prepared for operation. The averager shall be operated for its minimum period (about 30 seconds) and stopped. The altitude and time shall be noted. The altitude setting shall be changed by any amount up to 4 degrees, but not less than 10 minutes. The averager shall be operated for a period of 15 seconds and stopped. The altitude and time shall again be noted. This procedure shall be repeated changing altitude at random, both increasing and de-

creasing, to utilize full running time of the averager. The sum of the products of each altitude by its time of operation divided by the total time shall equal the averager altitude as computed by the averager to within ± 2 minutes of arc. This test shall be performed five times using different ranges of altitude and at least two tests shall involve radically different times of entry.

3-14. REMEDIAL ACTION. If the unit fails this test the averager must be adjusted as described in paragraph 2-45.

3-15. VARIABLE TIME AVERAGER (VTA)—ZERO ADJUSTMENT. After the instrument has been rewound, and before the averaging mechanism is put into operation, oscillation of the knob through 10 degrees range of reading shall not move the element of the averaging indicator by more than 0.010 inch for a series of five or more cycles.

3-16. REMEDIAL ACTION. Adjust averager as described in paragraphs 2-44 and 2-45.

3-17. VARIABLE TIME AVERAGER (VTA)—ZERO SETTING. After the averaging device has operated for a complete cycle of operation, it shall be rewound. When rewound, the indicator shall return to within ± 0.010 inch of its zero index mark.

3-18. REMEDIAL ACTION. Check for sticky index disks of the Yoke and Index Assembly. See paragraph 2-12 to 2-15.

3-19. VARIABLE TIME AVERAGER (VTA)—BACKLASH IN AVERAGING MECHANISM. After the instrument has run for the maximum time interval and before it is rewound, backlash in the averaging mechanism shall be determined by bringing the indicating elements and the index marker into coincidence first from one direction then from the opposite direction and noting the resultant sextant altitude readings. These readings shall not differ by more than 1 minute. To eliminate the effect of slippage, all operations of this test shall be done slowly.

3-20. REMEDIAL ACTION. Check all meshing gears, check side play of ball carriage. Check spring tensions as described in paragraphs 2-40 and 2-41.

3-21. MAXIMUM OPERATING PERIOD. The averager shall be operated three times for the maximum time interval. The length of time of each such period shall be 1 minute ± 2 seconds. This test may be combined with other tests if desired.

3-22. REMEDIAL ACTION. Adjust clock mechanism in averager. Adjust the control unit as described in paragraph 2-38.

3-23. SEXTANT CASE. The sextant case shall be inspected for signs of any form of deterioration or loose fitting components which would make it unfit for normal use.

3-24. REMEDIAL ACTION. Cement all loose parts or replace damaged parts.

**SECTION IV
DIFFERENCE DATA INDEX**

Kollsman Type
1972B-02

Page
37

Note

Overhaul and Test Procedures for the model included in this section are the same as procedures for type 1972-02 except for the specific differences noted by the applicable Difference Data Sheet. Sections II and III contain complete Overhaul and Test Procedure Information.

HANDHELD AIRCRAFT SEXTANT**KOLLSMAN TYPE 1972B-02**

THE INSTRUCTIONS CONTAINED IN PRECEDING SECTIONS OF THIS HANDBOOK APPLY, EXCEPT FOR THE SPECIFIC DIFFERENCES LISTED IN THIS DATA SHEET.

LEADING PARTICULARS

ALTITUDE: -10° to $+92^{\circ}$

VOLTAGE: 28 volts

CONTROL: One knob, 5° per revolution

SEALING: Sealed against moisture and fungus

OVERHAUL TOOLS REQUIRED: Same as for type 1972-02.

DISASSEMBLY: Same as for type 1972-02 except that the prism mount (7, figure 2-35) in the Sextant Body is secured by a flat head screw. There is no lockwasher (9) and no sealing ring (25).

CLEANING: Same as for type 1972-02.

INSPECTION: Same as for type 1972-02.

REPAIR OR REPLACEMENT: Same as for type 1972-02 with the following exceptions:

- a. The mirror unit uses mirror fluid DC200 having a viscosity of 7 centistokes.
- b. The eyepiece assembly, figure 2-38, contains an additional sealing ring on the lens mount and a new lens mount, allowing finer adjustment.
- c. The prism and lens mount assembly contains a new mount (31, figure 2-42), and a new mount and lens (22) which is now secured by two screws (18) and lockwashers (19).

LUBRICATION: Same as for type 1972-02.

REASSEMBLY: Same as for type 1972-02.

INTERNAL WIRING: Same as for type 1972-02 (figure 2-60) except that the rheostat has a 1700 ohm value.