



THE EBBCO SEXTANT

ITS USE, CARE AND ADJUSTMENT

BY J. G. P. WEATHERLAKE, M.R.I.N.

PRICE 10p.

CONTENTS

<i>Sec.</i>		<i>Page</i>
1	USE	4
2	THE SEXTANT The EBBCO Sextant described, with reference points on the illustration.	4
3	MICROMETER SCREW How to read minutes and seconds.	4
4	ADJUSTMENTS Checking mirror adjustment and making corrections.	5
5	INDEX ERROR Testing for error.	7
6	CARE Lubrication. Care of mirrors.	7
7	TAKING THE SIGHT Index Error. Use of shades. Bringing sun's image to horizon. Positioning sun on horizon.	7
8	TAKING THE TIME Gain or loss rate. Timing with two observers. Timing single handed. Use of stop watch.	9
9	MERIDIAN ALTITUDE Method of finding sun's height at Local Noon.	9
10	TRUE ALTITUDE Corrections to observed altitude. Index Error, Dip, Semi-Diameter, Refraction.	10
11	LATITUDE AND POSITION LINES Use of tables and calculations.	11
12	COASTAL NAVIGATION.. .. . Distance-off, Station Pointer fix.	13

ILLUSTRATIONS

Front Cover "A Sight at Last" from a drawing by David Cobb		
Fig. 1	.. The Sextant	3
.. 2	.. "Shooting the Sun"	5
.. 3	.. "Kissing the horizon"	8
.. 4	.. Dip	12
.. 5	.. Station Pointer plot	14
.. 6	.. Station Pointer in use on Chart	15

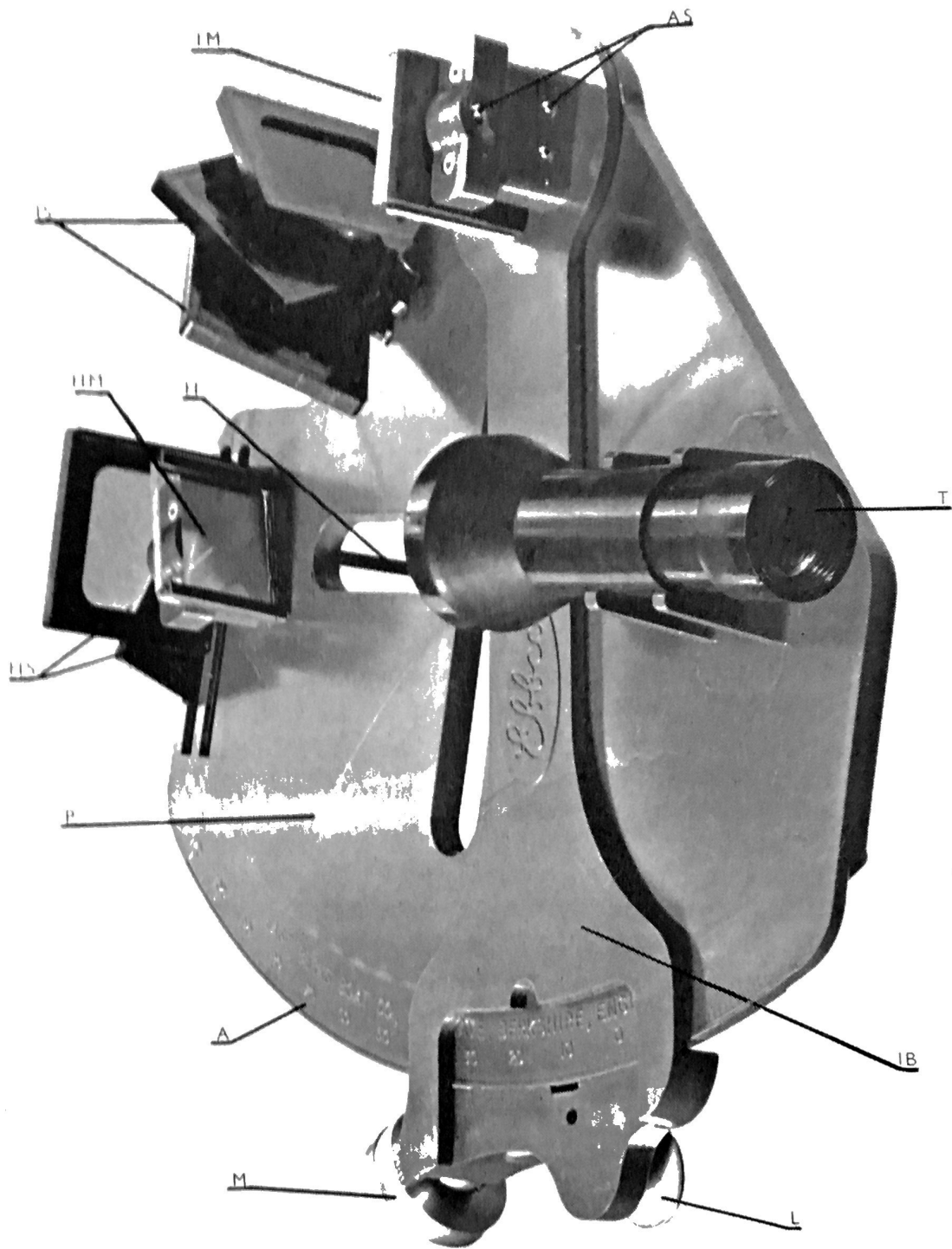

A: Arc	I.B.: Index Bar	P: Plate of Sextant	H.M.: Horizon Mirror
L: Lever	T: Telescope	I.M.: Index Mirror	H.S.: Horizon Shades
H: Handles	I.S.: Index Shades	M: Micrometer Drum	
A.S.: Adjusting Screws (<i>later models have only one adjusting screw for Index mirror</i>)			

Fig. 1

Spare parts can be obtained from East Berks Boat Co., Wargrave, Berkshire, England.

THE EBBCO SEXTANT

1 USE

The sextant is basically a simple instrument designed to measure an angle—either the altitude of the sun or other body in the sky, or the angle between two points on land. Altitudes, after reference to certain tables lead to a position line which can be plotted on the chart, and shore angles provide the data for a station pointer fix or a “distance-off.”

2 THE SEXTANT

Figure 1 shows the sextant with arrows pointing to the various parts. The handles are used for holding the sextant up to the eye, but they also serve as a rest, in place of legs. The flat upper surface is called the Plate of the sextant, and the moveable arm is the Index Bar. The Limb is the lower margin of the curved portion and is one-sixth the circumference of a circle; this fact gives the sextant its name (L. *Sextans*, sixth part). The system of reflection in a sextant uses the same beam of light twice, which doubles the angle, so although each graduation measures $\frac{1}{2}^\circ$, it represents a whole degree of altitude.

The telescope is set half way up the plate, at the zero end, its line of sight being through the Horizon Mirror, at the centre of the edge of the silvered portion; the horizon mirror is also fixed to the plate, and is at right angles to it. The Index Mirror is mounted on the index bar directly over the pivot point and is also perpendicular to the plate, but moves with the index bar. It reflects the image onto the horizon mirror, and thence through the telescope to the eye of the observer. There are three Index Shades of different densities between the index mirror and the horizon mirror which when used singly or in combination cut out the glare of the sun, one Horizon Shade to reduce glare on the horizon, and an Indexing Shade behind the horizon shade to enable the observer to obtain his Index Error on the sun.

3 THE MICROMETER SCREW

Attached to the Index Bar is an endless screw engaging in the rack on the back of the plate. One revolution of this screw moves the index bar one degree, and the graduations on the edge of the knob represent minutes. Zero is indicated when “0” on the knob is against the triangle on the lip of the index bar. The remaining graduations on the lip represent a Vernier Scale so that a reading to .2' may be taken, but from a small boat at sea, the sight is usually read to the nearest minute. To allow rapid travel of the index bar, the screw is disengaged from the rack by pressure on the stainless steel lever and for alterations of more than 2 or 3 degrees, the movement should always be made in this way.

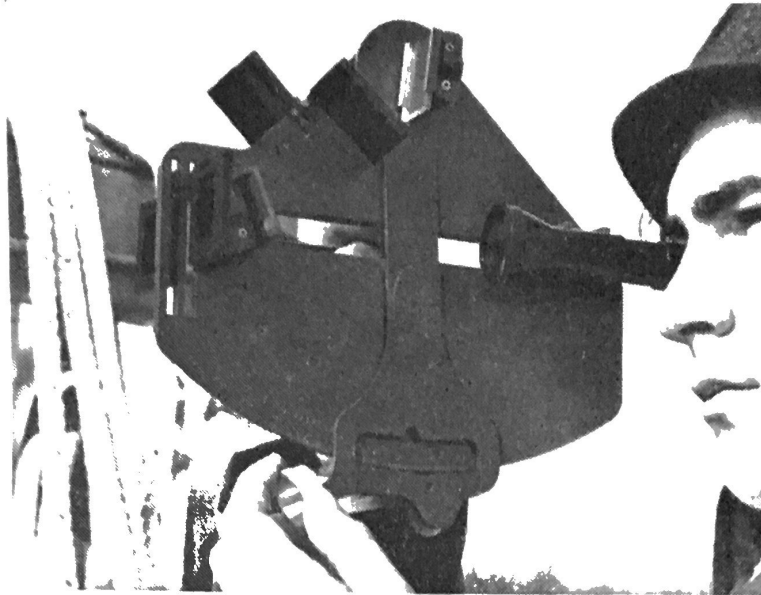

“ Shooting the Sun ”

Fig. 2

4 ADJUSTMENTS

After assembly the sextant is put into correct adjustment and tested for accuracy; but if it has been sent through the post the mirrors may have become slightly mis-aligned. When first opening the case you will find the sextant has the index bar set at approximately 40° and is placed in the case so that the index mirror is towards to top left hand corner of the case, where the adjusting key is housed. To remove the sextant from the case place a finger of the left hand in the centre of the cruciform, lift it out, and then hold it in the right hand by the handles. Never remove the sextant by handling the mirrors.

TESTS FOR CORRECT ADJUSTMENT

Examine the mirrors to make sure they are clear and bright and if necessary clean them lightly with a small piece of chamois leather. Then look between the mirror mount and the supporting block to ensure that the points of the adjusting screws are in contact with the mirror mount. The mirror mount is held in the block by a ball and socket system, so gentle pressure to one side or the other will move the mirror if it has to be re-positioned. The mirror should be roughly parallel in both planes with its supporting block. Now move the index bar so that the arrow points to approximately 60° . This is done by squeezing the stainless steel lever up towards the thumbhold on the index bar until the worm is lifted clear from the rack and then push the index bar along the arc. Reverse the sextant so that the index mirror is pointing towards you, plate uppermost. Look along the plate of the sextant and sight the part of the arc which you can see between the telescope and the index bar when the index mirror just blocks out the object glass of the telescope. You will then see a reflection of the arc in the mirror coinciding (or nearly so) with the portion of the arc that you can see beside the index bar. When

the reflection of the arc and the actual arc make one continuous line the index mirror is vertical to the plane of the sextant; if they don't, an adjustment is necessary to bring this about. Insert the long end of the adjusting key in the adjusting screw and give it a slight turn either way to move the image. Adjusting keys are cadmium plated, so if they are too tight to fit the socket comfortably, remove a little of the plating with a fine file or some other light abrasive.

Next the telescope is adjusted for vision. Hold the sextant to your eye as shown in the photograph Fig. 2, sight a distant object beyond the horizon mirror and move the draw tube out until the vision is clear.

To set the Index Bar at Zero, disengage the endless screw by squeezing on the stainless steel lever and move the index bar back so that the arrow is close to zero on the arc; turn the micrometer drum in the appropriate direction to bring zero on the drum against the arrow on the lip, and the arrow on the index bar opposite zero on the arc.

Select an object one to two miles away (anything closer than a mile will introduce parallax errors) such as the ridge line of a roof, a bridge or something which gives a definite line, and sight it through the telescope. The object will be on the left hand side and the reflection of the object in the silvered portion of the horizon mirror. The reflection and the object should form one continuous line and ideally a break should not be discernable. Adjustments are made with the adjusting key inserted in the adjusting screws. Insert the key in one of the screws and turn it slightly one way or the other to bring the images down together. If, for instance, the image is higher than the object, the key would be inserted in the screw which is nearest to the left hand end of the arc and screwed up carefully until the image moves. A delicate touch is needed and the fingers removed from the key for a final check. Then sight the end of this horizontal object and if it does not correspond with the image insert the key into the top adjusting screw (the one in the holding down block) and turn it either way to bring the images together. Slight movements are essential when carrying out these adjustments and one must work round the screws rather than try to make all the adjustment on one screw. When the sextant is in correct adjustment the mirrors are parallel in both planes with the blocks which support them and the socket ends of the adjusting screws are just showing through.

If difficulty is experienced in carrying out the mirror adjustments and it appears to be getting worse rather than better, undo all the adjusting screws until the socket ends are just showing through the blocks, position the mirrors by hand roughly parallel with the supporting blocks, and start again.

To avoid flexing error when indexing and sight taking always make the final movement of the knob clockwise (increasing the angle).

5 INDEX ERROR

Even after very careful adjustment it is unlikely that the sextant will be entirely free of Index Error, so the instrument is now tested for this. With zero set on both scales, sight a clear horizontal line a mile or two away; turn the drum about half-way round so that the reading is decreased and the image will move away from the actual object observed. Then turn the drum back again until the image and the object make a continuous line, and read the scale on the drum. If the reading is on the plus side of zero, the index error is said to be "on the arc". If it is on the negative side (say 57') then the error is 3 min. "off the arc". Each time a sight is taken the index error must be checked, and as it is more convenient to do this on the object being observed, an indexing shade is fitted against the horizon mirror for use when shooting the sun.

6 CARE

The Ebbco sextant is rugged and comparatively inexpensive, but it is also a delicate precision instrument and should be treated as such. All parts used in its manufacture are corrosion resistant but a salt atmosphere will affect the silvering on the mirrors. If the mirrors become dampened by salt spray, wash them clean with fresh water before putting the instrument away. It is even better to wash the whole instrument under fresh water and just shake it off rather than to leave salt water on the mirrors.

During assembly the rack and the bearing parts of the worm shaft are lightly lubricated with thin petroleum jelly. From time to time renew the lubrication on the rack, and if it is felt that the shaft is becoming stiff, the micrometer drum can be removed by loosening the grub screw holding it to the shaft, and some petroleum jelly put on the bearing surfaces with a narrow knife blade. Care must be taken to replace the micrometer drum in the same position on the shaft, and it should not be pressed on too tightly or a stiff movement will result. A size $\frac{1}{16}$ " AF Allen key will undo the 6" UNC grub screw.

With the sextant horizontal for coastal angles, gripping the stainless steel lever to keep the screw disengaged from the rack can press the jaws of the index bar against the underside of the arc; some thin petroleum jelly along here will make for easier operation.

The Nylatron washer on the pivot is self-lubricating, and this should not be touched.

7 TAKING THE SIGHT

On taking up the sextant never lift it by means of the mirrors; handle the plate and the handles only. When necessary, clean the mirrors very carefully using a small piece of chamois leather. To test for index error, set the Index approximately to zero and interpose a sun shade. Incline the sextant upwards and look at the reflected sun

through the telescope, being careful not to move the sextant far enough to the right for the sun to shine through the horizon glass with the eye unprotected by the sun shade. Gradually reduce the upward tilt of the sextant, at the same time (with the worm disengaged from the rack) sliding the index bar forward, so that the reflected sun remains visible in the right hand half of the "field." Continue to bring the sun down in this way until the horizon appears in the left hand half of the field. If the yacht yaws during the process the observer must twist his body so that the sextant is still vertically below the sun. A little practice will enable him rapidly to bring the sun down to the horizon without losing it. Allow the worm to engage in the rack and make the final adjustment with the micrometer drum.

This method is essential for star sights, but with the sun, an experienced observer can estimate roughly the altitude, and setting that on the sextant, finds the sun near the horizon by a fairly rapid "square search".

A small boat at sea does not, as a rule, provide a steady platform for a sight; so when time allows, a series of three or five sights should be taken one after the other and a position line obtained from the average of these times and readings. This average can be obtained arithmetically or by plotting on squared paper. Any obviously bad sight should be discarded.

Figure 3 shows the sun being made to kiss the horizon. A true kiss can only be achieved with practice and if the observer finds that all his altitudes tend to err in one direction or the other, he should try putting the sun a little higher or a little lower; when over-anxious to get a sight the usual failing is to kiss too lightly, thus getting a lower altitude than true.

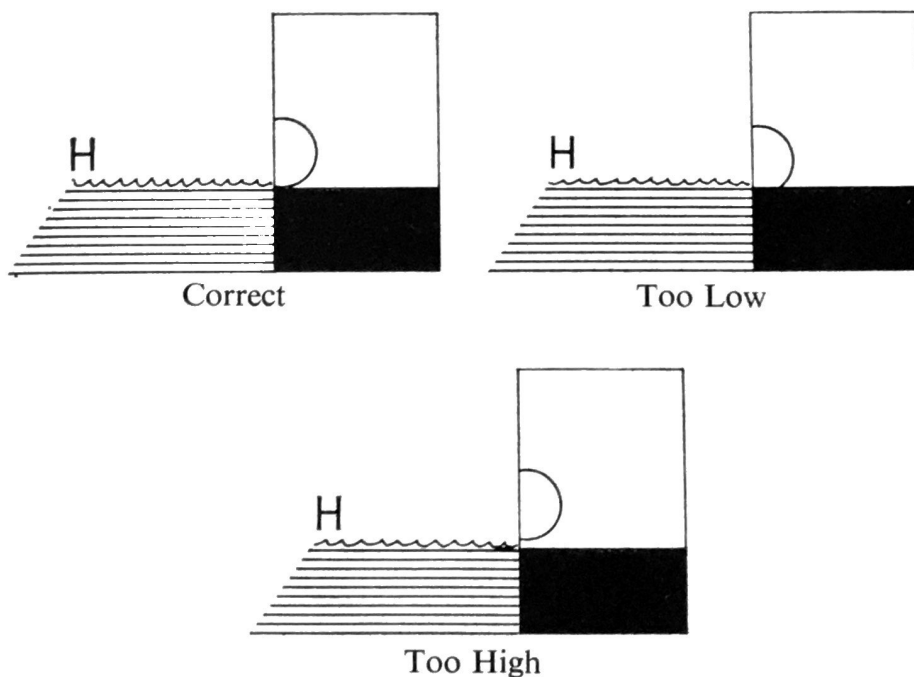

Fig. 3

Care must be taken to bring the reflected sun down directly under the true sun—that is the plate of the sextant must be vertical; otherwise the observation will not be correct. This can be checked by moving the sextant pendulum fashion. The sun will lift off the horizon at either side of the perpendicular; so the lowest point the sun comes to on the swing will be the position for the sextant to make the observation.

8 TAKING THE TIME

It is essential, when taking a sight, to have Greenwich Mean Time. In these days, when most boats have a wireless receiving set, constant check by time signals will keep the chronometer accurately set, and a "Rate of Loss or Gain" established. With two people available to take a sight, the one shooting, when he is about to bring the body to the horizon, will call "Stand By." The time-keeper on the chronometer will then start counting the seconds—"twenty-two, twenty three, twenty four," or wherever the second hand is,—and as the observer makes contact, he calls "Stop." The time keeper notes down the number of seconds at that instant, then reads the minutes, then the hours. Mistakes are often made when reading the minutes, and for this reason the minutes reading is invariably checked a second time.

If the observer is on his own, instead of calling "Stop," he starts counting—as close as he can to the seconds rate—and as he takes the reading of the chronometer, he applies the correction of the number of seconds he has counted since taking the sight. A stop watch can often be held in the right hand—the right thumb on the knob holding the watch against the sextant handle—and started at the instant of taking the sight. The time can then be read from the chronometer, allowing the elapsed interval as shown by the stop watch as a correction.

9 MERIDIAN ALTITUDE

It is well known that during A.M. (anti-meridian) hours, the sun is slowly climbing. During P.M. (post-meridian) it is slowly sinking. At the moment the sun is at its highest point in the sky, it is noon at the point of observation. This is called Apparent Noon. A short while (say 15 mts.) before this point is expected, the sun should be brought to the horizon. The sun's climb can now be watched and is followed by moving the index bar with the micrometer drum.

Eventually no further movement will be apparent, and the altitude stays steady for a minute or two, after which it starts to dip. The maximum reading is the meridian altitude, and when the appropriate corrections have been applied gives the latitude of the ship. The working for this can be prepared in advance, thus the latitude can be ascertained almost immediately the altitude is read.

10 TRUE ALTITUDE

Having observed the altitude of the sun with our sextant, we have certain corrections to apply to find the true altitude. These are:—

- I. Index Error
- II. Dip
- III. Semi-diameter
- IV. Refraction

INDEX ERROR

This has already been discussed. “On the Arc” corrections must be subtracted, “Off the Arc” correction is added.

DIP

When taking a sight, we are finding the angle which a celestial body makes with a tangent to the circumference of the earth, at the point of observation. If we stand on the sea shore, and use the sea horizon, our “Height of Eye” is about six feet. Therefore it will be seen that our line of sight to the horizon is not tangential to the earth’s circumference (Fig. 5) and the greater the height of eye (on a boat, or on the bridge of a ship), the greater will be the angle beyond the tangent. Observers H.E. (height of eye) must be judged, and from the table for dip in the Nautical Almanac, the correction (always subtracted) is applied. Wave height must also be brought into consideration. A sight taken with a H.E. of 14ft., and wrongly judged 18ft. would introduce an error of $\frac{1}{2}$ min.

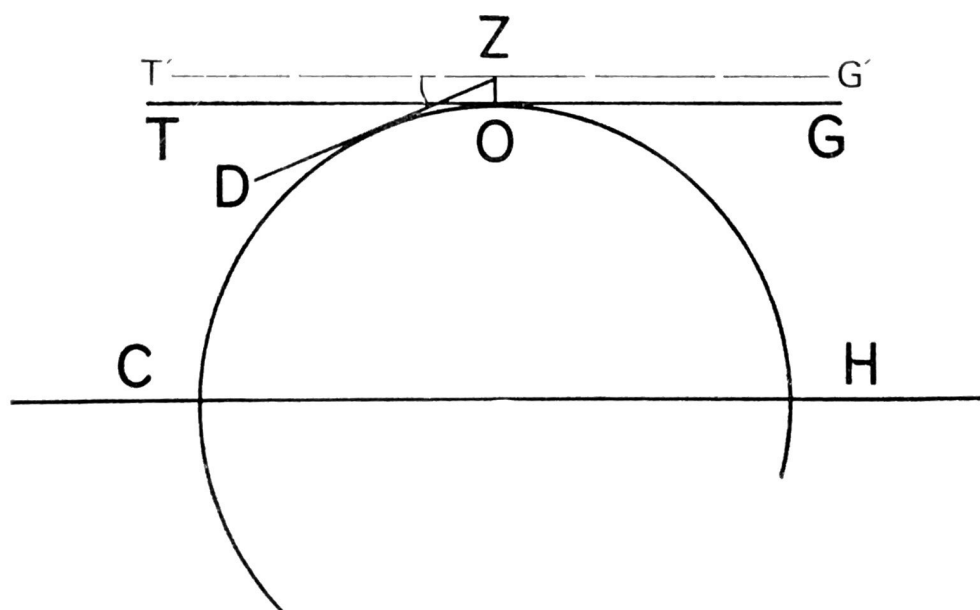

O:—Observer; C, H:—Celestial Horizon; T, G:—Tangent
T', G':—Parallel to Tangent at H.E.
Z:—Height of Eye; T', Z, D:—Angle of Dip

Fig. 4

SEMI-DIAMETER

The true altitude of the sun (or moon) is taken to the centre of the body. A far more accurate observation of altitude can be made by using the upper or lower limb on the horizon. The almanac lists the Semi-Diameters, and this correction is applied according as to which limb was brought to the horizon. It ranges a little either side of 16' for the Sun.

REFRACTION

Rays of light, as they pass through the earth's atmosphere, are bent. Therefore a correction must be made for this. It is listed in the Nautical Almanac against the Apparent Altitude, and is always subtracted.

The calculation from apparent altitude to true altitude then becomes:—

Obs. Alt.	56° 51'
Index Error	+ 2'
	<hr/>
	56° 53'
Dip (H.E. 10ft.)	— 3'.2
	<hr/>
	56° 49'.8
Semi-Diam (lower limb).. .. .	+ 15'.8
	<hr/>
	57° 05'.6
Refraction	— .6
	<hr/>
True Altitude	57° 05'

11 POSITION LINES

It can be shown that at any given time the ship is on the circumference of a Circle of Position, having as centre the position on the earth where the sun is directly overhead and radius the zenith distance (90° —altitude). As this position line is at right angles with the azimuth or bearing of the sun, when the sun bears North or South, the Position Line is the Latitude. (The radius is so great that the useful part of the circumference can be regarded as a straight line).

When ever possible at sea the Meridian Altitude is taken each day and the latitude deduced by the formula.

$$\text{Latitude} = \text{Zenith Distance} \pm \text{Declination.}$$

Declination is taken from the almanac and in this case it is N $21^\circ 01'$. When the declination is the same name as the lat., it is added; a different name, it is subtracted.

$$\begin{aligned} \text{Latitude} &= (90^\circ - 57^\circ 05') + 21^\circ 01' \\ &= 53^\circ 56' \end{aligned}$$

Preparing for this Noon Sight in advance, we work backwards
 Our total correction is 14 min.

Total correction (subtract)	—	90° 00'	}	prepared beforehand
		14'		
Declination		89° 46'		
		21° 01'		
		110° 47'		
Observed Altitude		56° 51'		(sextant reading)
Latitude		53° 56'		

When a sight is taken at a time other than at Noon, the position line is found very simply with the aid of the Sight Reduction Tables (AP 3270). The sight in the following example was taken from a large yacht as she approached Cape Finisterre after crossing the Bay of Biscay; I am indebted to the navigator, Sir John Holder, for allowing me to use it as an illustration.

31st July, 1963 Sun D.R. 44° N
 8° W

GMT 07, 19, 27	Corrected Obs. Alt.	19° 49'
(From the almanac) 283° 24.7'	Chosen Lat.	44° N.
4° 51.8'	Dec. ..	18° 26.0'
		— .2'
GHA 288° 16.5'		18° 26.0'N.
Chosen Long. W — 8° 16.5'		
LHA 280°		

The chosen Longitude makes the LHA a whole number:

The chosen Latitude is a whole number:

AP 3270 is entered with these and the nearest dec. whole number:

From page 30 of vol. 3 we get

Alt	d	Az
19° 29'	39	N.83E.
17'	(extra minutes of dec., using d, page 338)	
19° 46'		
19° 49'	(observed altitude)	
Intercept 3'	towards Sun.	

The chosen position is then plotted on the chart, the azimuth laid off from it, and the intercept, 3' measured from it towards the Sun. The position line is then ruled through this latter point at right angles to the Azimuth.

Position Lines are especially useful when the sun is abeam; the above example enabled the navigator, using a simple position line to check his course-made-good, and so achieve a good landfall.

The AP 3270 is compiled in three volumes which cost £1 5s. each. Vol. 1 is for selected stars in all latitudes; vol. 2 is for Sun, Moon, and planets for latitudes 0°—39°; vol. 3 contains similar tables for latitudes 40°—89°. An introduction describes their use, and a table at the back provides GHA and declination of the sun for the years 1953—2000.

12 COASTAL NAVIGATION

Accurate fixes can be obtained from vertical angles to a known height, and also from simultaneous horizontal angles to three suitable points.

DISTANCE OFF AND BEARING

If a feature whose height is known is in sight, a vertical angle will give distance off. This is a circular position line, with the observed height as centre. Radius is worked out from the equation

$$\text{Distance off in miles} = \frac{\text{Height of object (in ft.)} \times .565}{\text{Vertical angle in minutes}}$$

Tables for “Distance-off” are in most almanacs, and an instant calculator is incorporated in the EBBCO Combined Station Pointer and Distance-off Calculator.

Immediately the sight is taken, take the bearing of the observed height, and this will give you an absolute fix.

OBSERVATION OF TWO KNOWN HEIGHTS

When two known heights are suitably placed, a vertical angle of each, taken in quick succession, will give two circular position lines. They will cut in two places, but no difficulty will be experienced in deciding which one to use.

STATION POINTER

When two suitable features can be observed to either side of a central point, the angle the outside ones make with the centre one can be measured by holding the sextant in the horizontal plane, with the Index Bar uppermost.

These angles can be applied to the chart using a Station Pointer, by ruling them on a transparent protractor having a matt surface and a central hole, or by drawing them similarly on a piece of tracing paper.

When choosing features for this fix certain placings will give the best results when—

1 The three points are in the same straight line or the centre point is more towards the observer than away.

2 Two of the points are more or less the same distance from the observer and the third is at an angle greater than 30° .

The angles should be at least 30° .

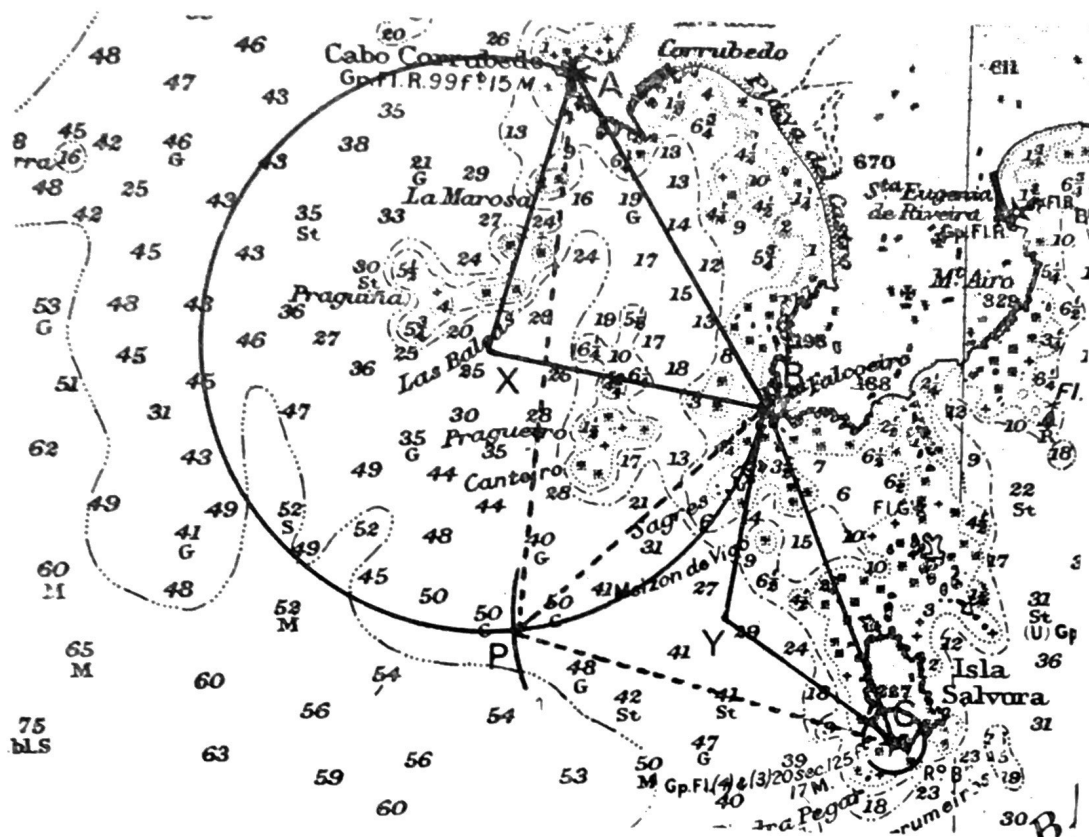

Reproduced from Admiralty Chart No. 1752 with the sanction of the Controller of Her Majesty's Stationery Office and the Hydrographer of the Navy.
Fig. 5

To plot, join the points observed, A to B and B to C. The observed horizontal angle between A and B is 42° ; subtract this from 90° .

$$90^\circ - 42^\circ = 48^\circ.$$

Lay off angles of 48° from A and from B, to intersect at X, making an isosceles triangle.

Using X as centre, and radius XB, draw a circle over the seaward area.

The horizontal angle between B and C was observed to be 57° .

$$90^\circ - 57^\circ = 33^\circ.$$

Construct angles of 33° at B and C to intersect at Y. Using Y as centre, cut the circle already drawn, at P.

This is your position.

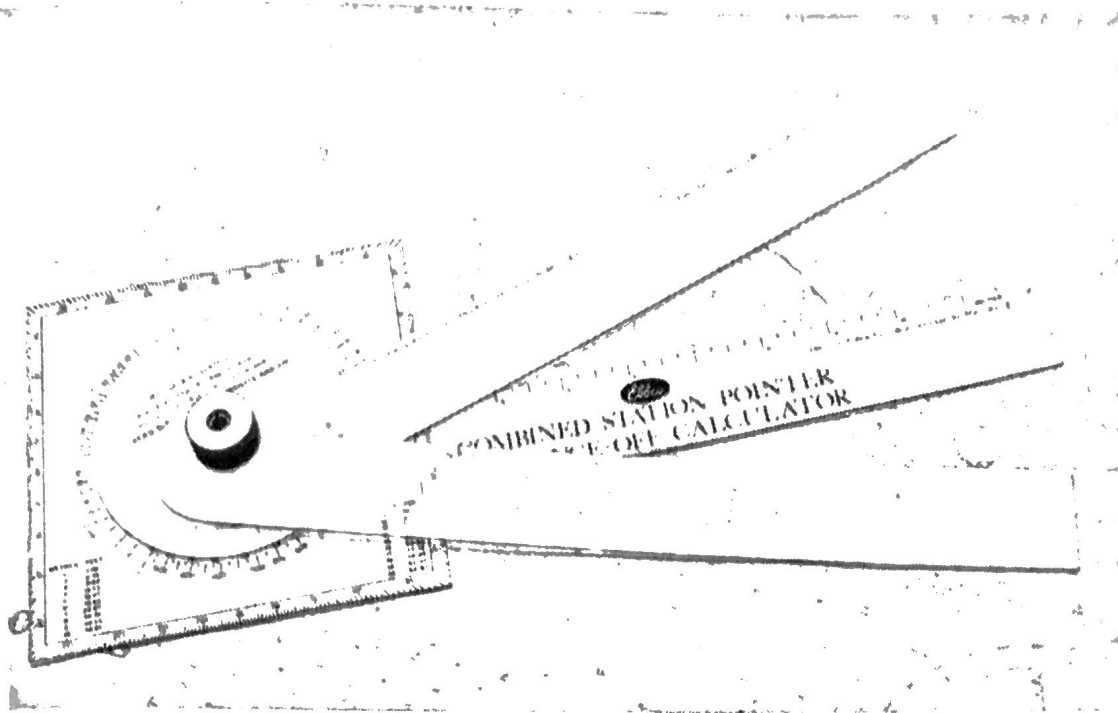

Reproduced from Admiralty Chart No. 2045 with the sanction of the Controller of H.M. Stationery Office and the Hydrographer of the Navy

The EBBCO Combined Station Pointer and Distance-off Calculator being used to obtain a fix off the Isle of Wight

Fig. 6

When a Station Pointer is available, the navigator is relieved of this chart work. The moveable arms are set to the observed horizontal angles and the instrument placed on the chart with the arms passing through the corresponding features, as shown in fig. 6. The position is marked through the centre knob.

